

Viera[™]
Breast ultrasound by **Clarius**[®]

HOLOGIC[®]

Viera[™] **Portable**
Breast Ultrasound
User Manual

Disclaimer:

This disclaimer extends to all printed matter accompanying the Viera™ Portable Breast Ultrasound.

This manual is licensed under the Terms and Conditions available at www.clarius.me/terms-conditions/. You may not use this manual except in compliance with the license. The information contained in these materials is proprietary and confidential to Clarius Mobile Health Corp. (“Clarius”) and is provided for the sole use of the individual or entity to whom it is addressed and therefore these materials must be kept in the strictest confidence. No portion of this manual may be copied, reproduced, republished, modified, sold, disclosed, or distributed without the prior written permission of Clarius. Unauthorized copying or distribution of this manual, in addition to infringing copyright, may reduce the ability of Clarius to provide updates and current information to users.

Clarius has taken care to ensure the accuracy of this document, however, revisions may not be possible in all situations. Information in this document may be subject to change without notice, and Clarius assumes no liability for errors or omissions. Clarius reserves the right to make changes without further notice to any products herein to improve reliability, function, or design. Clarius may make improvements or changes in the products or programs described in this document at any time.

These materials may contain third-party copyright and/or trademark materials, the use of which has not always been specifically authorized by the intellectual property owner. All copyrights and/or trademarks contained in these materials are the sole and exclusive property of their respective owners.

“Clarius”, the Clarius logo, “Ultrasound Anywhere,” “Point-and-Shoot Ultrasound”, and “Act One” are trademarks or registered trademarks, and are the sole and exclusive property of Clarius.

The Clarius products/services referenced in this document may be covered by one or more patents or pending patent applications. See www.clarius.me/patents/ for details.

All names used in Clarius (whether online, in print, or any other media) are fictitious and are used herein for the purposes of example and demonstration on how to use the Viera™ Portable Breast Ultrasound. Any similarity to real people is a coincidence.

© 2018 Clarius Mobile Health Corp.

All rights are reserved. Reproduction or transmission in whole or in part, in any form or by any means, electronic, mechanical or otherwise, is prohibited without the prior written consent of the copyright owner.

Published in Canada.

15-03-00055



Hologic Technical Support

USA Support Center: (877) 371-4372
+1 (781) 999 7750
BreastHealth.Support@hologic.com

European Support Center: +32 2 711 45 45
BE-Techsupport@hologic.com

Australia Support Center: 1800 264 073
+61 2 9888 8000

Table of Contents

<i>About This Manual</i>	1
<i>Target Audience</i>	1
<i>Document Conventions</i>	2
Touch Gestures.....	2
Icons.....	3
Symbols Glossary.....	3
Chapter 1: About the Viera™ Portable Breast Ultrasound	9
Scanner Description	10
Scanner Dimensions.....	12
Product Usage.....	12
Indications for Use	12
Viera™	13
Contraindications	15
For Use in Surgical Environments.....	15
Hardware.....	15
Warranty.....	15
Disposal.....	15
Security	16
Information Security.....	16
Network Security.....	16
Confidentiality.....	17
Integrity	17
Availability.....	18
Accountability.....	18
System Requirements.....	18
Chapter 2: A Quick Tour	20
Overview of the Interface.....	20
Icons	20
Menu Icons.....	20
Tools Icons	21

Status Icons	22
Menu Options.....	23
Support.....	23
Settings.....	23
Options	24
Screen Calibration	24
Local Storage	25
Scanner Information	25
Scanner Customization	25
Exams	26
Clarius Cast.....	27
About.....	28
Sign Out.....	29
Screen Overview.....	29
Sign-in Page.....	29
Scanners Page.....	30
Workflows Page.....	31
Patient Demographics	32
Indications Page	32
Imaging Page.....	33
Review Page	34
Impressions Page	34
System Capabilities.....	35
Status Lights.....	35
Audible Notifications	35
Sleep Mode.....	36
Auto Shutdown	36
Scanner Locator.....	36

Chapter 3: Using the Viera™ Portable Breast Ultrasound 38

Downloading the Clarius App.....	38
Apple iOS	38
Android™	39
Updating the Viera™ Portable Breast Ultrasound	39
Software Updates	39
Firmware Updates.....	39
Inserting & Removing the Battery	40
Inserting the Battery	40
Removing the Battery	40
Turning the System on & off	41
Starting the Clarius App	41

Exiting the Clarius App	41
Signing in & out	41
Signing in	41
Signing out.....	42
Connecting Your Smart Device to Viera™	42
Connecting Apple iOS Devices to Scanners	42
Connecting Android™ Devices to Scanners	43
Managing Exams	44
Starting New Exams.....	44
Pausing an Exam.....	45
Ending an Exam	45
Resuming a Paused Exam.....	45
Managing Patient Information.....	46
Entering Patient Information	46
Populating Indications.....	46
Selecting Scanning Modes.....	47
B-Mode	47
Color Doppler	48
Power Doppler.....	51
M-Mode	51
Imaging	53
Adjusting Gain	53
Turning Auto-Gain on & off	53
Manually Adjusting Gain	54
Using the Center Line.....	55
Using Needle Enhance	56
Using Automated Heart Rate.....	57
Freezing/Unfreezing Cine-loops	58
Capturing Cine-loops & Images	60
Saving Cine-loops.....	60
Saving Images	61
Zooming in & out	62
Changing Depth.....	63
Rotating Images.....	63
Using Annotations.....	64
Labeling Images	64
Using Pictograms	66
Using the Measuring Tools	67
Common Measuring Tools	67
Measurement Accuracy	67

Measurement Accuracy Table	68
Using the View-Sharing Mode.....	68
Using Chromecast™	70
Review Findings	70
Reviewing Cineloops & Images	70
Deleting Items	70
Populating Impressions.....	71
Exporting Exams	71
Maintenance	71
Hardware Maintenance.....	72
Testing Scanners	72
Recharging Batteries	72
Storing Scanners	73
System Maintenance	74
Sending Activity Logs.....	74
Help.....	74
Additional Training.....	74
Error Messages	74
Need Help?	74
Chapter 4: Accessories	75
Clarius Dock	75
Parts	76
Technical Specifications.....	77
System Specifications.....	77
Setting up.....	78
Using the Clarius Dock.....	78
Using the Scanner Coolers.....	78
Using the Battery Charger.....	79
Using the Smart-Device Charger	79
Maintenance.....	79
Troubleshooting.....	80
Clarius Fan.....	80
Chapter 5: Cleaning & Disinfecting	83
Cleaning.....	84
Cleaning the Viera™ Portable Breast Ultrasound	84
Cleaning the Clarius Fan.....	85
Disinfecting.....	85

Disinfecting the Viera™ Portable Breast Ultrasound	85
Intermediate Disinfection.....	86
High-Level Disinfection.....	86
Disinfecting the Clarius Fan	87
Spaulding Classification	88
Chapter 6: Safety.....	89
About Diagnostic Ultrasounds.....	89
Interactions with Matter.....	89
History	89
Studies.....	90
Benefits & Risks.....	90
Safety Topics	91
Product Safety	91
Product Warnings.....	91
Product Compatibility.....	92
Battery Safety	92
Cleaning Safety	93
Cleaners & Disinfectants.....	93
Minimizing the Effects of Residual Disinfectant	93
Factors Affecting Disinfectant Efficacy	94
Scanner Care	94
Clinical Safety.....	95
Syringe Safety.....	95
Defibrillator Safety.....	95
Biological Safety	95
Latex.....	95
Bioeffects.....	96
Thermal	96
Mechanical (Non-Thermal)	96
ALARA Principle	97
Applying ALARA.....	98
Using System Controls to Implement ALARA	98
Direct Controls	98
Indirect Controls	99
Receiver Controls	99
User Responsibility	99
Output Display.....	100
Display Standards	100
Display Accuracy	101
Controls Affecting Display Indices	102
Acoustics	103
Acoustic Artifacts	104

Acoustic Output & Measurement	104
In Situ, Derated, & Water Value Intensities	104
Conclusions Regarding Tissue Models & Equipment Survey	105
Acoustic Measurement Precision & Uncertainty	106
Fire & Electrical Safety	107
Fire Safety.....	107
Electrical Safety.....	107
Electromagnetic Safety	108
Electromagnetic Compatibility.....	108
Electrostatic Discharge Precautions.....	109
Electromagnetic Emissions.....	109
Electromagnetic Immunity	110
Electromagnetic Interference	110
Separation Distance	111
Recommended Separation Distance	111
Avoiding Electromagnetic Interference	112
Regulation of Low-Power Motor for Radio Wave Range	113

Chapter 7: References 114

Compliance Statement.....	114
The Viera™ Portable Breast Ultrasound	114
Authorized Representative.....	114
Product Classification	114
Product Serial Number.....	115
System Specifications.....	115
Scanner Specifications	117
Viera™ Portable Breast Ultrasound	117
Standards.....	117
Biocompatibility.....	117
Chemical	118
Electrical Safety.....	118
Federal.....	118
Labeling.....	118
Quality	119
Performance.....	119
Risk, Product Specification, Design Review, & Verification/Validation.....	120
Security & Privacy.....	121
Wireless.....	121
Doppler Sensitivity	122
Viera™ Scanner	122
Acoustic Output Tables	123

Viera™ Scanner: B-Mode & M-Mode	123
Viera™ Scanner: Color Doppler Mode	124
Viera™ Scanner: Needle Enhance Mode	125
Control Effects Guidance Documents.....	126
Cleaners & Disinfectants	126
Cleaner & Disinfectant Usage	126
Cleaner & Disinfectant Details	127
Known Issues	127
Glossary of Terms	127
Acoustic Outputs.....	127
Acoustic Artifacts	130
Revision History	132

About This Manual



To obtain a printed copy of this manual at no additional cost, please contact Hologic Technical Support.

This document is licensed as part of the purchase of the Viera™ Portable Breast Ultrasound and meets international regulatory requirements such as the FDA. Use of this document by unauthorized persons is strictly prohibited.

This document contains the following information:

- About the Viera™ Portable Breast Ultrasound: Describes the product, and lists technical specifications, and its intended use.
- A Quick Tour: Shows you how to get started and begin scanning.
- Using the Viera™ Portable Breast Ultrasound: Introduces you to the features and concepts, helps you set up your system, and explains the tasks you can perform.
- Accessories: Describes additional accessories you can purchase for use with your Viera™ Portable Breast Ultrasound.
- Cleaning & Disinfecting: Explains how to clean and disinfect your scanner.
- Safety: Outlines important safety standards, principles, and policies to follow when using the product.
- References: Offers information such as product standards, regulatory requirements, terms and conditions, glossary of terms, and acoustic output data.









Access to user documentation may be affected by: Internet availability and accessibility, website availability, and local electromagnetic interference.

Target Audience



This document is written for trained medical professionals who operate and maintain your Viera™ Portable Breast Ultrasound. It contains instructions and reference material pertaining to the usage and maintenance of the product.

Document Conventions

Touch Gestures

Gesture	Title of gesture	Description
	Drag	Touch the screen with a finger and move the finger across the screen without lifting the finger.
	Double tap	Touch the screen briefly twice with the same finger.
	Pinch	Touch the screen with two fingers and move them toward each other.
	Tap	Touch a control with your finger.
	Press and hold	Touch the screen for a short time without moving your finger.
	Spread	Touch the screen with two fingers and move them apart.
	Swipe	Touch the screen with your finger and move the finger in a quick motion right, left, up, or down.







Icons

Icon	Title of Icon	Description
	Alert	Possible risks beyond the reasonable control of Clarius.
	Do not do this	This icon indicates actions to avoid.
	Note	This icon indicates informative material or helpful suggestions.















Symbols Glossary

You may see some of these standard symbols on your Viera™ Portable Breast Ultrasound, accessories, and packaging:













STANDARD: ISO 7000—GRAPHICAL SYMBOLS FOR USE ON EQUIPMENT—REGISTERED SYMBOLS

Symbol	Reference	Title	Description
	3082	Manufacturer	Indicates the medical device manufacturer, as defined in EU Directives 90/385/EEC, 93/42/EEC and 98/79/EC.
	2497	Date of manufacture	Indicates the date when the medical device was manufactured.
	2607	Use by date	Indicates the date after which the medical device is not to be used.
	2492	Batch code	Indicates the manufacturer's batch code so that the batch or lot can be identified.
	2493	Catalogue number	Indicates the manufacturer's catalogue number so that the medical device can be identified.
	2498	Serial number	Indicates the manufacturer's serial number so that a specific medical device can be identified.









STANDARD: ISO 7000—GRAPHICAL SYMBOLS FOR USE ON EQUIPMENT—REGISTERED SYMBOLS

	2499	Sterile	Indicates a medical device that has been subjected to a sterilization process.
	2500	Sterilized using aseptic processing techniques	Indicates a medical device that has been manufactured using accepted aseptic techniques.
	2501	Sterilized using ethylene oxide	Indicates a medical device that has been sterilized using ethylene oxide.
	2502	Sterilized using irradiation	Indicates a medical device that has been sterilized using irradiation.
	2503	Sterilized using steam or dry heat	Indicates a medical device that has been sterilized using steam or dry heat.
	2608	Do not resterilize	Indicates a medical device that is not to be resterilized.
	2609	Non-sterile	Indicates a medical device that has not been subjected to a sterilization process.
	2606	Do not use if package is damaged	Indicates a medical device that should not be used if the package has been damaged or opened.
	3084	Sterile fluid path	Indicates the presence of a sterile fluid path within the medical device in cases when other parts of the medical device, including the exterior, might not be supplied sterile.
	0621	Fragile; handle with care	Indicates a medical device that can be broken or damaged if not handled carefully.
	0624	Keep away from sunlight	Indicates a medical device that needs protection from light sources.
	0615	Protect from heat and radioactive sources	Indicates a medical device that needs protection from heat and radioactive sources.
	0626	Keep away from rain	Indicates a medical device that needs to be protected from moisture.
	0534	Lower limit of temperature	Indicates the lower limit of temperature to which the medical device can be safely exposed.

STANDARD: ISO 7000—GRAPHICAL SYMBOLS FOR USE ON EQUIPMENT—REGISTERED SYMBOLS





	0533	Upper limit of temperature	Indicates the upper limit of temperature to which the medical device can be safely exposed.
	0632	Temperature limit	Indicates the temperature limits to which the medical device can be safely exposed.
	0224	Measure humidity	Indicates the range of humidity to which the medical device can be safely exposed.
	2621	Atmospheric pressure limitation	Indicates the range of atmospheric pressure to which the medical device can be safely exposed.
	0659	Biological risks	Indicates that there are potential biological risks associated with the medical device.
	1051	Do not re-use	Indicates a medical device that is intended for one use, or for use on a single patient during a single procedure.
	1641	Operator's manual; operating instructions	Indicates the need for the user to consult the instructions for use.
	0434A	Caution	Indicates the need for the user to consult the instructions for use for important cautionary information such as warnings and precautions that cannot, for a variety of reasons, be presented on the medical device itself.
	2494	Control	Indicates a control material that is intended to verify the performance characteristics of another medical device.
	2495	Negative control	Indicates a control material that is intended to verify the results in the expected negative range.
	2496	Positive control	Indicates a control material that is intended to verify the results in the expected positive range.
	3083	In vitro diagnostic (IVD) device for performance evaluation	Indicates an IVD device that is intended to be used only for evaluating its performance characteristics before it is placed on the market for medical diagnostic use.
	2715	Sampling site	On medical devices or blood process application: to indicate that the device or process application includes a system dedicated to the collection of samples of a given substance stored in this medical device or blood container.

STANDARD: ISO 7000—GRAPHICAL SYMBOLS FOR USE ON EQUIPMENT—REGISTERED SYMBOLS

	2722	Fluid path	Indicates the presence of a fluid path.
	2724	Non-pyrogenic	Indicates a medical device that is non-pyrogenic.
	2726	Drops per milliliter	Indicates the number of drops per milliliter.
	2727	Liquid filter with pore size	Indicates an infusion or transfusion system of the medical device that contains a filter of a particular nominal pore size.
	2728	One-way valve	Indicates a medical device with a valve that allows flow in only one direction.
	2610	Patient number	Indicates a unique number associated with an individual patient.
	1135	General symbol for recovery/recyclable	To indicate that the marked item or its material is part of a recovery or recycling process.
	2725	Contains or presence of	On medical devices: to indicate that the equipment contains the identified product or substance.







You may see some of these standard symbols on your Viera™ Portable Breast Ultrasound, accessories, and packaging:

OTHER STANDARDS—GRAPHICAL SYMBOLS FOR USE ON EQUIPMENT—REGISTERED SYMBOLS



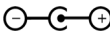







Symbol	Standard	Reference	Title	Description
	ISO 7010	M002	Refer to instruction manual/booklet	Indicates to read the instruction manual/ booklet before starting work or before operating equipment or machinery.
	IEC 6417	5172	Class II equipment	To identify equipment meeting the safety requirements specified for Class II equipment according to IEC 60536.
	IEC 6417	5957	For indoor use only	To identify electrical equipment designed primarily for indoor use.
	IEC 6417	5333	Type BF applied part	To identify a type BF applied part complying with IEC 60601-1.

You may see these other symbols on your Viera™ Portable Breast Ultrasound, accessories, and packaging:

OTHER GRAPHICAL SYMBOLS FOR USE ON EQUIPMENT

Symbol	Title	Description
	Contains sufficient for <n> tests	Indicates the total number of IVD tests that can be performed with the IVD kit reagents.
	In vitro diagnostic medical device	Indicates a medical device that is intended to be used as an in vitro diagnostic medical device.
	Power connector	Indicates a barrel-type power connector.
	RoHS compliant	Identifies electrical and electronic equipment that meets the Restriction of Hazardous Substances (RoHS) Directive 2011/65/EU.
	European Conformity	Conforms to European Council Directive 93/42/EEC.
	FCC	Conforms to US Federal Communications Commission.
	CSA certification	Certified by the Canadian Standards Association. The number below this symbol indicates the contract number.

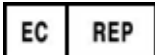
OTHER GRAPHICAL SYMBOLS FOR USE ON EQUIPMENT

	<p>Waste Electrical and Electronic Equipment</p>	<p>Requires separate collection for electrical and electronic equipment in compliance with the Waste Electrical and Electronic Equipment (WEEE). Directive. When accompanied by  or , components of the device may contain lead or mercury, respectively, which must be recycled or disposed of in accordance with local, state, or federal laws. The backlight lamps in an LCD system monitor contain mercury.</p>
<p>IP67</p>	<p>Ingress protection rating</p>	<p>The equipment inside the enclosure is protected from tools and wires greater than 2.5 millimeters, and is also protected from immersion up to 1 meter in depth for 30 minutes.</p>
	<p>DC</p>	<p>Direct current.</p>
	<p>GS1 DataMatrix</p>	<p>Identifies GS1 encoded DataMatrix.</p>
	<p>Global Medical Device Nomenclature Code</p>	<p>A system of internationally agreed generic descriptors used to identify all medical device products.</p>
	<p>Global Trade Item Number</p>	<p>An identifier to look up product information in a database, often by entering the number through a bar code scanner pointed at an actual product.</p>
	<p>Model name</p>	<p>Model name for the device.</p>
	<p>Authorized representative in the European Community</p>	<p>Indicates the Authorized representative in the European Community.</p>
	<p>ANATEL</p>	<p>Conforms to the Brazilian Agency of Telecommunications.</p>

About the Viera™ Portable Breast Ultrasound



Install, operate, and maintain this product according to the safety and operating procedures in this manual, and only for its intended purpose. Always use the information in this document with sound clinical judgment and best clinical procedures.

This product is subject to the law in the jurisdiction that the product is used. Install, use, and operate the product only in ways that adhere to applicable laws or regulations, which have the force of law.



- Product package must be maintained with medical device. Do not dispose.
- Using the product incorrectly, or for purposes other than those intended and expressly stated by Clarius and/or Hologic, may relieve Clarius and/or Hologic or its agents from all or some responsibility for resultant noncompliance, damage, or injury.
- Using portable and mobile radio-frequency (RF) communications equipment can affect the operation of medical equipment.
- Operating this system in the presence of flammable gases or anesthetics can cause an explosion.
- Install and operate medical equipment according to electromagnetic compatibility (EMC) guidelines.
- Users are responsible for image quality and diagnosis.
- This device complies with part 15 of the FCC rules. Operation is subject to the following two conditions: (1) this device may not cause harmful interference, and (2) this device must accept any interference received, including interference that may cause undesired operation.
- This product has demonstrated EMC compliance under conditions that included the use of compliant peripheral devices. It is important that you use compliant peripheral devices to reduce the possibility of causing interference to radios, televisions, and other electronic devices.

Scanner Description

The Viera™ Portable Breast Ultrasound is a portable, general purpose, software controlled, diagnostic ultrasound system used to acquire and display high-resolution, real-time ultrasound data through a COTS (commercial off-the-shelf) Apple iOS or Android™ device. The Viera™ Portable Breast Ultrasound series of wireless scanners are Bluetooth and Wi-Fi-based scanners that communicate with a traditional tablet/smartphone via direct Wi-Fi to allow users to export ultrasound images and display in different modes of operation. The Viera™ Portable Breast Ultrasound houses a battery and power generator, multichannel beamformer, prescan converter and Wi-Fi components. The battery is removable and comes with a separate charger.

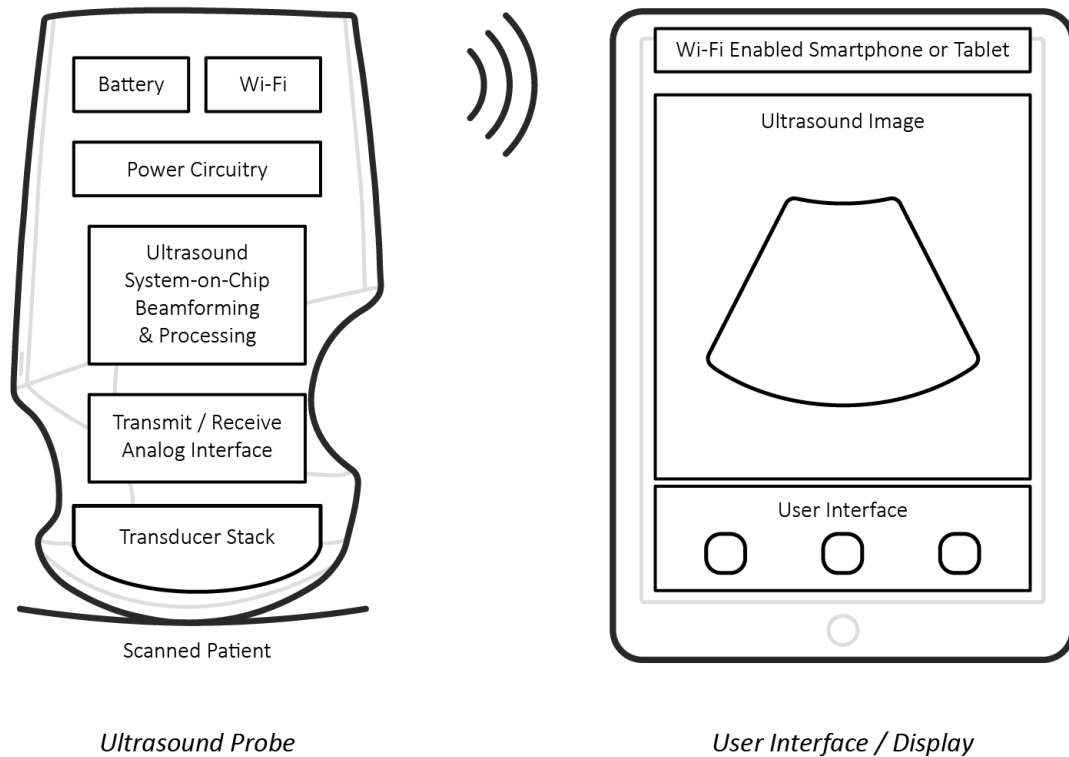

Battery manufacturer	Clarius
Battery model number	99-02-00001
Battery chemistry	Li-ion
Battery management	JEITA guideline compatible charger, in-pack fuel gauge with protection circuitry, cell balancing, and temperature monitoring
Battery life	500 - 1000 discharge cycles before reduction in charge
Charger	Input: 100-240 VAC, 50/60 Hz, 0.5-0.2 A Output: 12 VDC, 1.5 A
Scanner	7.2 V/2350 mAh

- Clarius App
- Scanners: All scanners have 192 elements

The concept of the Viera™ Portable Breast Ultrasound and software is primarily to provide an easy to use, high-performance, low-cost, ultrasound platform for teaching and clinical applications.

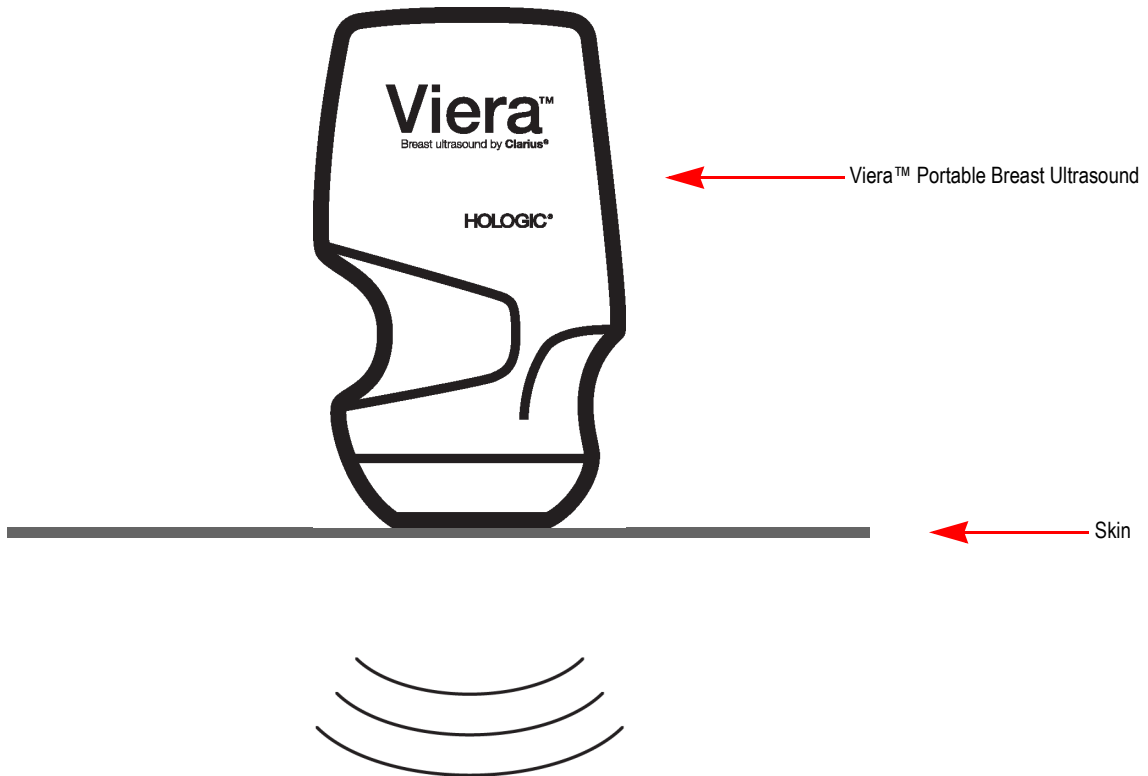

- Circumstances in the patient's environment may negatively impact the scanner and the exam. For example: (1) Chemicals and gases in the operating room. (2) Altitudes below -382 m or above 4000 m.
- Vulnerable patients, such as children and pregnant/nursing women, may be more prone to the exposure of acoustic energy when the scanner is used for prolonged periods.
- Biological incompatibility may exist between the scanner materials used and the biological tissues, cells, and body fluids of the patient/user, taking account of the intended purpose of the scanner.
- Using the scanner in the patient environment may be unsafe if the following conditions exist: (1) Extremes in humidity (RH<15% and RH>90%). (2) Ambient temperatures that are excessively high (40°C / 104°F) or excessively low (0°C / 32°F).

Users will be trained medical professionals (e.g., doctors, nurses, technicians) with previous training in ultrasound. Images produced by the scanner are transmitted wirelessly to the user's smart device (tablet or smart phone).

Caution: Federal law restricts this device to sale by or on the order of a physician.



Unqualified/untrained personnel purchasing and using the Viera™ Portable Breast Ultrasound may be unable to attain quality images.

Scanner Dimensions

Item	Length (in/mm)	Width (in/mm)	Height (in/mm)	Weight (oz/g)
Viera™ Scanner (without battery)	6.7 in/169 mm	4.1 in/105 mm	1.6 in/41 mm	15.4 oz/437 g
Battery	2.8 in/70 mm	3.0 in/75 mm	0.7 in/17 mm	3.6 oz/103 g
Battery charger (without plug adapter)	3.2 in/80 mm	3.5 in/89 mm	1.3 in/32 mm	1.9 oz/55 g

Product Usage

Indications for Use

The Viera™ Portable Breast Ultrasound is a software-based ultrasound imaging system and accessories, intended for diagnostic imaging. It is indicated for diagnostic ultrasound imaging and fluid flow analysis in the following applications: ophthalmic, fetal, abdominal, intra-operative (non-neurological), pediatric, small organ, cephalic (adult), musculo-skeletal (conventional, superficial), urology, gynecology, cardiac (adult, pediatric), fetal echo, peripheral vessel, carotid, and procedural guidance of needles into the body.

The system is a transportable ultrasound system intended for use in environments where healthcare is provided by trained healthcare professionals.

Viera™

DEVICE NAME: VIERA™

INTENDED USE: DIAGNOSTIC ULTRASOUND IMAGING OR FLUID FLOW ANALYSIS OF THE HUMAN BODY AS FOLLOWS:

Clinical Application		Mode of Operation						
General (Track 1 Only)	Specific (Tracks 1 & 3)	B	M	Color Doppler	Power Doppler	PW Doppler	Combined (Specify)	Other*
Ophthalmic	Ophthalmic	P						
Fetal Imaging & Other	Fetal							
	Abdominal	P	P	P	P		B+M; B+CD; B+PD	Note 1
	Intra-operative (Abdominal organs & vascular)	P	P	P	P		B+M; B+CD; B+PD	Note 1
	Laparoscopic							
	Pediatric	P	P	P	P		B+M; B+CD; B+PD	Note 1
	Small Organ (Thyroid, Prostate, Scrotum, Breast)	P		P	P		B+CD; B+PD	Note 1
	Neonatal Cephalic							
	Adult Cephalic							
	Trans-rectal							
	Trans-vaginal							
	Trans-urethral							
	Trans-esophageal (non-Cardiac)							
	Musculo-skeletal (Conventional)	P	P	P	P		B+M; B+CD; B+PD	Note 1
	Musculo-skeletal (Superficial)	P	P	P	P		B+M; B+CD; B+PD	Note 1
	Intravascular							
Other (Urology, Gynecology)								
Cardiac	Cardiac Adult							
	Cardiac Pediatric							
	Intravascular (Cardiac)							
	Trans-esophageal (Cardiac)							
	Intra-cardiac							
	Other (Fetal Echo)							

DEVICE NAME: VIERA™**INTENDED USE: DIAGNOSTIC ULTRASOUND IMAGING OR FLUID FLOW ANALYSIS OF THE HUMAN BODY AS FOLLOWS:**

Peripheral Vessel	Peripheral Vessel	P	P	P	P		B+M; B+CD; B+PD	Note 1
	Other (Carotid)	P	P	P	P		B+M; B+CD; B+PD	Note 1

N = new indication; P = previously cleared by FDA; E = added under this appendix

Note 1: Needle Enhancement in B-Mode.

Contraindications



Do not use the Viera™ Portable Breast Ultrasound in the following situations. Doing so may produce images with inaccurate results:

- Patients who have had surgery, which may have changed the composition of the examining tissue (for example, a mastectomy), as this could skew or alter the measured density.
- Patients whose bodies contain foreign artifacts (for example, implants), in the examining tissue.

For Use in Surgical Environments

Before you use the Viera™ Portable Breast Ultrasound for intra-operative procedures, follow the instructions for high-level disinfection (for instructions see *High-Level Disinfection* on page 86), then cover the Viera™ Portable Breast Ultrasound with a sheath:

- Use only CIVCO REF 610-1212.
- Download the usage instructions from <http://civco.com/mmi/ultrasound/covers/general-purpose/Latex-Free-Wireless-Ultrasound-Probe-Covers-610-1212.htm> and read all the information before use.

When you have finished using the Viera™ Portable Breast Ultrasound, immediately clean it (for instructions see *Cleaning the Viera™ Portable Breast Ultrasound* on page 84), followed by another high-level disinfection.

If the sheath breaks during the intra-operative procedure, dispose the sheath and follow the same cleaning and high-level disinfecting process as above, then cover the Viera™ Portable Breast Ultrasound with a new sheath before continuing to use it.

Hardware

Warranty

Your Viera™ Portable Breast Ultrasound includes a one-year warranty. To purchase extended warranty, contact your Hologic representative.

Disposal

Hologic is an active participant in the protection of the natural environment. The equipment and its accessories are designed and manufactured according to environmental protection guidelines, and the disposal of this equipment is intended to follow the same principles. The

equipment materials that are essential for functionality are also harmful to the natural environment, therefore, you must dispose these materials appropriately.

For proper disposal of the Viera™ Portable Breast Ultrasound or any of its accessories, dispose it in accordance with local, state, and federal regulations. Alternatively, you can return it to Hologic.



The improper disposal of the Viera™ Portable Breast Ultrasound (when the battery is no longer working or the scanner has exceeded its shelf life), or any of its accessories, adds hazardous materials to our landfills.

Security

Information Security

When entering data using the Clarius App, it is your responsibility to protect your security credentials (e.g. passwords) and the personal information of patients (e.g. names).

Network Security

When connecting your smart device, use a network that supports Wi-Fi 802.11n. We recommend that you secure this network using WPA (Wi-Fi Protected Access) or WPA2 (Wi-Fi Protected Access II) as your security protocol.

For information on setting up your wireless network security, refer to your network equipment's documentation.



You may run into situations where no wireless access point is available. Using an untrusted wireless access point may allow malicious parties to see your Wi-Fi signals, perform harmful actions, and view communications between the two smart devices. When no secure access point is available, operate the Clarius App in Wi-Fi Direct mode, and it will automatically set up encryption.

For security purposes:

- Use secure passwords.
- Use secure wireless equipment using the latest firmware and software, and secure protocols.
- Lock your smart devices.

The following actions could introduce new risks to patients, operators, and third parties. It is your organization's responsibility to identify, analyze, evaluate, and control these risks:

- Changing network configurations.
- Connecting to additional networks or disconnecting from existing networks.
- Upgrading to new equipment or updating existing equipment.

Confidentiality

Confidentiality of information is assured as follows:

- The scanner contains no patient-identifying information.
- When the scanner connects to a wireless network, it encrypts and stores the Wi-Fi password.
- The data transferred between the smart device and the Clarius App is encrypted.
- Image data contains no patient- or user-identifying information, and is transmitted in unencrypted form. If you want this data encrypted, connect to a:
 - Wi-Fi network where only trusted parties are permitted. The Wi-Fi network encrypts all image data sent from other Wi-Fi networks.
 - Wi-Fi Direct network. The Wi-Fi Direct network encrypts all image data, and because no other users are on the Wi-Fi Direct network, the image data is confidential.
- The smart device stores patient and user data in a private location. After 30 days in the Clarius Cloud, the patient data is removed.

Integrity

Integrity of the data transmitted between the smart device and the Clarius App is assured as follows:

- Authenticated encryption prevents malicious users from intercepting and modifying data.
- Integrity checks ensure completion and validity of data received. If any data is incomplete or invalid, it is discarded.
- TCP channels used over Wi-Fi ensures that data is delivered correctly. For transmitting image data, a UDP channel is used.

Availability

If Wi-Fi connection is unattainable (e.g. Wi-Fi access points are unavailable or the network is down), use Wi-Fi Direct network, which is managed by the smart device. Because Wi-Fi Direct network is a peer-to-peer connection using the Wi-Fi protocol, it disallows other users from connecting, thereby reducing DDOS (Distributed Denial of Service) attacks.

If the Wi-Fi Direct network is disrupted, the smart device continues to monitor itself, and shuts down after a period of inactivity. This reduces acoustic energy transmission and battery usage.

Accountability

The concept of accountability does not apply to the Viera™ Portable Breast Ultrasound. However, ownership (i.e. the active user) of a smart device is assigned to one user at a time. Once you begin using the smart device, no other user can connect to the same smart device. All data transmitted between the smart device and the Clarius App is owned by the active user.

System Requirements

Using the Viera™ Portable Breast Ultrasound on a smart device that does not meet the minimum requirements may result in low-quality images, unexpected results, and possible misdiagnoses.

To run the Clarius App, a smart device must meet or exceed the following minimum specifications:

Technical Features:

- Supports Bluetooth LE v4.0+
- Supports Wi-Fi 802.11n and Wi-Fi Direct
- 8 GB of hard-drive (on-board)
- 512 MB of memory

Operating System:

- Android™ 4.4.2 (API 19)+ or Apple iOS 9.0+

Processor:

- Dual core processor (CPU)
- ARM-based CPU architecture (for Android™-based devices)

Display:

- Resolution (in pixels) of 960x640 (or 640x960)
- Contrast ratio of 800:1
- Supports OpenGL ES 2.0

Supported smart devices:

Apple iOS:

- iPad 3rd generation+
- iPad Air+
- iPad Mini+
- iPhone 5S (iPhone 4S partially supports Wi-Fi 802.11n at 2.4GHz, but not at 5GHz)
- iPod Touch 5th generation+

Android™ 4.1+:

- Devices with Wi-Fi 802.11n
- Devices with BLE 4.1

Note: Performance of BLE (Bluetooth low energy) varies by model.



- Access to user documentation is dependent on the proper download and installation of the Viera™ Portable Breast Ultrasound on your smart device.
- Using a smart device that is too small may not have the necessary resolution for viewing small structures.

A Quick Tour

2









Overview of the Interface

Icons

Menu Icons

Menu icons are navigational tools at the top of the screen that takes you to a different page.





































MENU ICONS

	Home page.		Support page.
	Scanners page. Scan QR Code page.		Settings page.
	Display menu list.		Exams page.
	About page.		Sign out.
	Clarius Cloud webpage.		

Tools Icons

Tool icons are task buttons that perform an action when you select them.





















TOOL ICONS

	Discard selected item.		Save image.		Freeze/unfreeze a live-scanning image. Disable auto-freeze.
	Return to previous page.		To flip the image on its axis, drag this icon left/right or up/down.		Disconnect active scanner and turn off its power.
	Go to next page.		To begin measuring, tap this icon and select a measuring tool.		Open Clarius' Facebook page.
	Display search field.		To create a single measure, tap two areas on the image		Open Clarius' Twitter page.
	Clear contents.		To create a dual measure, tap two areas on the image to draw one line, repeat to draw second line.		Open Clarius' LinkedIn page.
	Submit.		To draw a circumference, drag your finger around the region of interest.		Open Clarius' Instagram page.
	Zoom in/out of image.		To draw a circle, tap two areas on the region of interest.		Open Clarius' Google Plus page.
	Open the tools list.		To toggle auto-gain on/off, select this icon from the tools list.		Open Clarius' YouTube page.
	Save cineloop.		Display center line on live imaging.		Use B-Mode of imaging.
	Use Color Doppler mode of imaging.		Use Power Doppler mode of imaging.		Use Needle Enhance feature.
	Use M-Mode of imaging.		Add annotations.		Select a pictogram from the options.
	View image on normal speed.		View image on slow speed.		Reverse the colors on Color Doppler image.

Status Icons

Status icons are view-only indicators that animate or change color to show the status of a component.

STATUS ICONS

	Quality of network connection is good. Yellow, orange, or red indicates varying degrees of congestion.		Image is zoomed out.
	Bluetooth signal from a nearby scanner is weak, satisfactory, or excellent.		Auto-gain is turned on.
	Wi-Fi Direct has been selected for this connection.		Scanner is in sleep mode.
	Wi-Fi has been selected for this connection.		Number of in-progress exams.
	The Clarius App is waiting for your selection (e.g. update firmware or select network).		Number of exams waiting to be uploaded to the Clarius Cloud. These images will automatically upload to the Clarius Cloud the next time you have network connection.
	The scanner you selected is now connected to the Clarius App. Tapping this icon displays the temperature, battery power, and option to display QR code.		Exam has successfully uploaded to the Clarius Cloud.
	Scanner is uploading a new software package.		Images are currently being uploaded to the selected DICOM server.
	Scanner is updating to the latest software package. During this time, do not remove battery from the scanner.		Images have successfully uploaded to the selected DICOM server.
	Scanner is cool. Red indicates that it is warm. Tapping this icon displays the temperature in degrees Celsius.		Images are currently being exported to your smart device's camera roll.
	Scanner's battery power. Tapping this icon displays the percentage of battery power remaining.		Images have successfully uploaded to your smart device's camera roll.
MI/TI	Acoustic display indicators.		Image is zoomed in.

Menu Options

Support

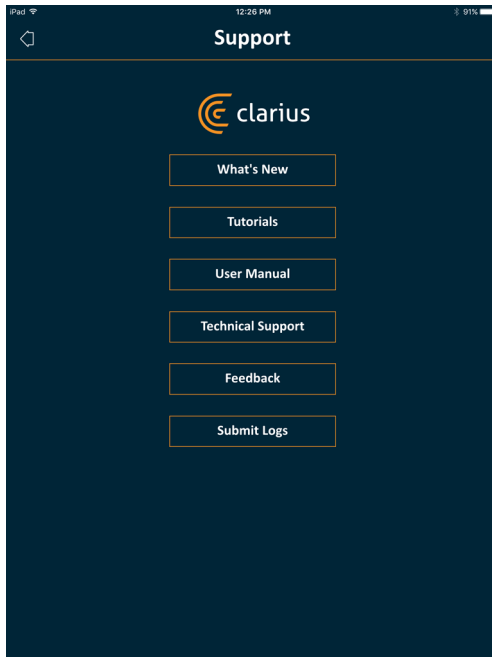

Displays the following buttons:

- What's New: Takes you to the webpage containing frequently asked questions.
- Tutorials: Takes you to the webpage containing tutorials.
- User Manual: Takes you to the webpage containing the user manuals.
- Technical Support: Opens your default email account with pre-populated fields for asking questions about the product.
- Feedback: Opens your default email account with pre-populated fields for sending general feedback about the product.
- Submit Logs: The Viera™ Portable Breast Ultrasound sends the system logs to the Clarius Cloud. For more information, see *Sending Activity Logs* on page 74.

Settings

When you make changes in the Settings page, the new values display the next time you sign in.



Options

- Control Placement: The location of the controls on the Imaging page.
- Scanner Shutdown Timeout (minutes): Select the number of minutes of inactivity before the scanner shuts down.
- Scanner Performance:
 - High Performance: Optimum power level.
 - Power Savings: Reduced power level for longer scan times and lower heat.
- Automated Heart Rate: This setting is shown if your Clarius App is currently connected to a scanner. This automated heart rate feature, available only in the cardiac workflow, measures the heart rate when you scan the heart. For instructions on using this feature, see *Using Automated Heart Rate* on page 57.
- Post Capture Freeze: If disabled, capturing a cineloop continues imaging. If enabled, capturing a cineloop freezes the image.
- Show Virtual Scanners: Displays virtual scanners on the Scanners page. Virtual scanners are used to simulate the Viera™ Portable Breast Ultrasound for demonstration and evaluation purposes.

Screen Calibration

To obtain optimal screen-viewing for your current operating environment, adjust the contrast on your smart device by using the horizontal grayscale calibration slider. Contrast adjustment is useful when swapping one smart device with another, or when extending the view of the current exam on a second smart device; or in any situation where the brightness of one screen

you are using is different from another. If your smart device is equipped with an auto-brightness feature, you may want to turn this feature off. The brightness control affects only the monitor, not the saved images.

Local Storage

Press  to clear the log files. Note that deleting these log files could make it difficult or impossible for Hologic Technical Support to provide help in certain situations.

Scanner Information

Connect the Clarius App to a Viera™ Portable Breast Ultrasound to view the following information:

- **Scanner Information:** Details about the scanner such as name, model, and serial number.
- **Factory Reset:** Clears all stored Wi-Fi information and other cached data.
- **Reset Wi-Fi Settings:** Select this button if your Wi-Fi password changes. This clears all stored Wi-Fi network passwords and resets the Wi-Fi Direct password.
- **Identify:** Locates the scanner with an audible sound. See *Scanner Locator* on page 36.

Scanner Customization

Connect the Clarius App to a Viera™ Portable Breast Ultrasound to view the following information:

- **Wi-Fi Direct Settings:** This section lets you program the network name and password.
- **Auto-Boot:** If disabled, inserting the battery sets the scanner to standby mode. From here you will manually connect the Clarius App to the scanner. If enabled, inserting the battery automatically connects the Clarius App to the scanner. If it fails to connect within two minutes, the scanner will go to sleep mode.

This page displays a list of exams that have been uploaded to the Clarius Cloud. If you delete the Clarius App and re-installed it, it will remove these records.

Exams

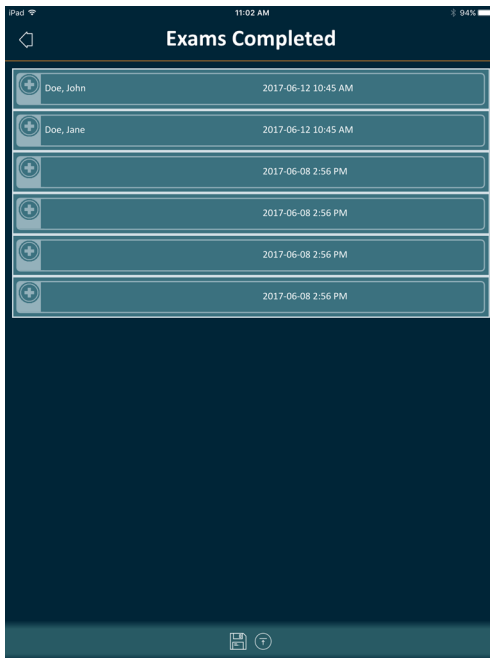

This page displays a list of completed exams and the status of any uploads or exports.

▼ To view exams currently uploading to the Clarius Cloud:

Go to the home screen and select .

Clarius Cast

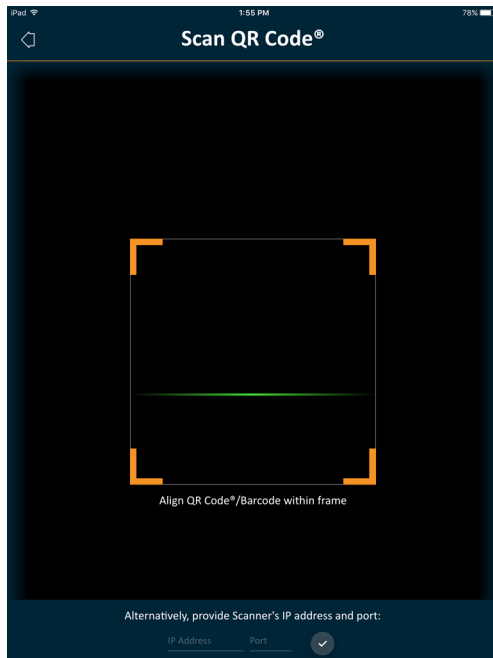

When using the QR Code® / barcode reader, if you have multiple barcodes close to each other, adjust the frame to ensure you restrict the frame size to display only one barcode in the window.

You can connect up to five smart devices to an active Viera™ Portable Breast Ultrasound for viewing real-time exams. This lets patients hold a separate smart device to view their images while the ultrasound technician conducts the exam using their own smart device. It also lets students have view-only access to live exams performed by an instructor. For instructions on using the view-sharing mode, see *Using the View-Sharing Mode* on page 68.

About



Displays the following information:

- Version of the Clarius App and Viera™ Portable Breast Ultrasound software
- Copyright information

Links to:

- Terms & Conditions
- Privacy Policy
- Acknowledgments
- About Us

Social media pages for:



Facebook



Twitter



LinkedIn



Instagram



Google+



YouTube

Sign Out

Select this menu option to sign out of the Clarius App. If an exam is currently in progress, it will be saved in the list of in-progress exams.

Screen Overview

Sign-in Page

When you open the Clarius App, it displays a sign-in screen.



- **Create Account:** This takes you to the account creation page. To create a new account, enter your email address using the same domain that your administrator used to register, and then create yourself a strong password containing the following parameters:
 - At least six characters
 - At least one upper case, digit, or special character

Once registered, you can go to the Clarius Cloud to add details to your account.

- **Forgot Password:** This takes you to the Clarius webpage for resetting your password.
- **Need Help:** This takes you to the Clarius webpage containing contact and help information.



Scanners Page

When you sign in, the Clarius App displays the Scanners page. This page lists active scanners in your area to which you have access rights. If your Clarius App cannot locate your scanner, either because the scanner is powered off or because it is located outside its Bluetooth range, the scanner is grayed out on the list.

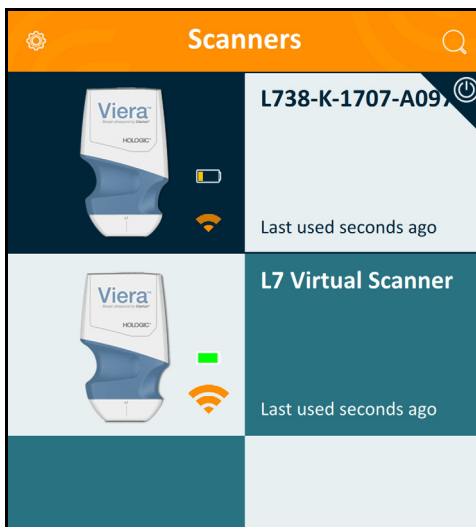
A  beside a Viera™ Portable Breast Ultrasound indicates that you have no access to it. To access this scanner, contact your administrator.



The Scanners page displays the following:

- A representative image of the scanner type.
- The currently selected scanner is displayed at the top of the list, indicated by . Tapping this icon disconnects the scanner from your smart device. It also turns off the scanner's power.
- The Bluetooth RSSI (signal strength) .
- Custom scanner name. You can define this in the Clarius Cloud.
- Length of time since last activity.

▼To choose your Viera™ Portable Breast Ultrasound's settings:

Tap  to display the following options:

- Wi-Fi Direct: The scanner creates a peer-to-peer network connection using Wi-Fi protocol.
- the name of your Wi-Fi network
- Wi-Fi Direct Channel: This is shown if you have Wi-Fi Direct selected. For best results, keep the Auto option selected, it auto-connects the Clarius App to the most recently used Viera™ Portable Breast Ultrasound. To use this feature, your smart device must support 5GHz Wi-Fi.

Workflows Page

Exam types are characterized as workflows, a sequence of steps to complete an exam. Workflows guide you towards collecting all the information needed to produce a complete and accurate report for the reviewing physician.

Only those exam types applicable to the selected Viera™ Portable Breast Ultrasound are displayed in the Workflow page. See following tables for list of exams.

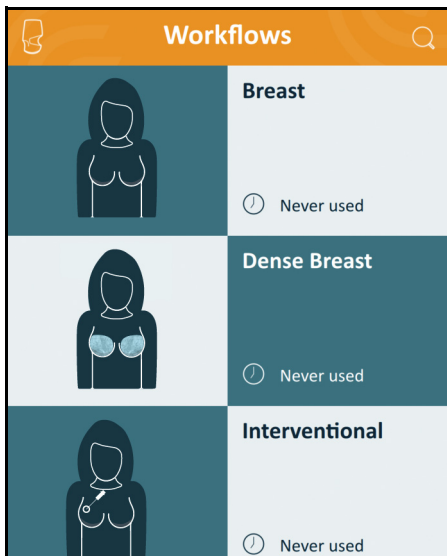

▼To search for a workflow:

- Scroll through the options.
- Enter search field: Tap the  to display the search field and enter your search criteria. The Clarius App accepts partial searches.

WORKFLOWS AVAILABLE WITH THE VIERA™

Workflow	B-Mode	M-Mode	Power Doppler	Color Doppler	Needle Enhance
Breast	X	X	X	X	X
Dense Breast	X	X	X	X	X
Interventional	X	X	X	X	X

Patient Demographics

This is where you enter the patient’s basic information.

The screenshot shows a form titled "Patient Demographics" with an orange header. Below the header is a progress indicator with five steps, where the first step is active. The form contains the following fields:

- PATIENT ID
- LAST NAME
- FIRST NAME
- MIDDLE NAME
- DATE OF BIRTH
- GENDER (with radio buttons for Female, Male, and Other)
- ACCESSION NUMBER

You can tap on a field to display a barcode icon and scan their ID bracelet using your smart device's barcode scanner. The Accession field is a unique identifier assigned to images when uploading to DICOM.

Indications Page

This is where you can enter notes such as the patient’s medical history, current symptoms, allergies, and medications.

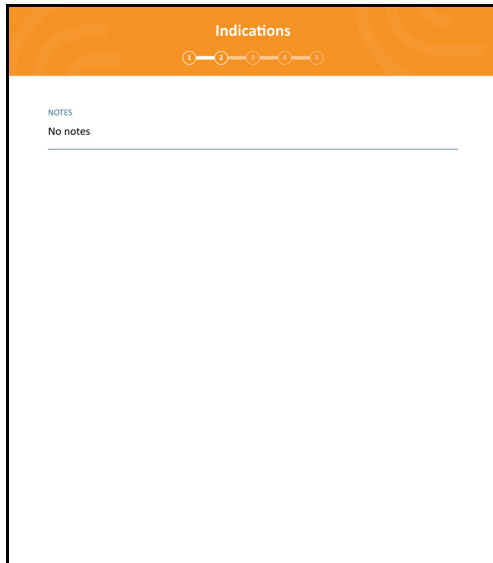

Imaging Page

This is the live imaging screen.

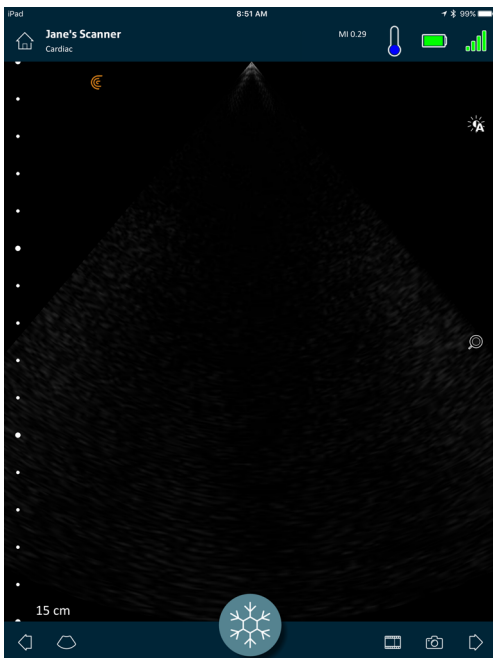

Review Page

When you have finished imaging, you can evaluate and edit findings that were acquired during the exam.

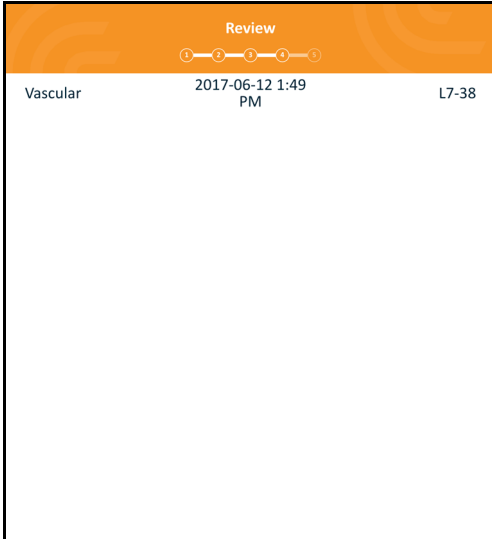

Impressions Page

After reviewing the images, use this page to record your findings.

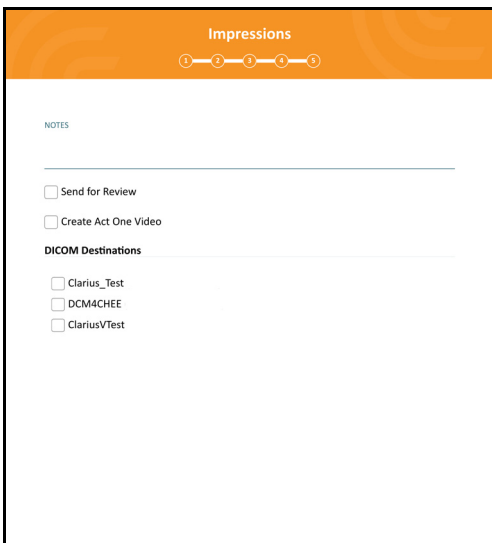

System Capabilities

Status Lights

The following table defines the Viera™ Portable Breast Ultrasound's status lights:

Color	Display	Meaning
Blue	Flashing	Scanner is booting up.
Blue	Solid	Scanner is ready for a Wi-Fi connection, or has a connection and is not imaging.
Green	Solid	Scanner is imaging.
Orange	Flashing	Battery is low.
Orange	Solid	Internal communications error. ^a
Red	Flashing	Battery is critically low.
Red	Solid	Critical boot-up error has occurred. ^a
Purple	Flashing	Software/firmware is updating. Do not remove battery.

a. Remove the battery from the scanner, wait 10 seconds, re-insert the battery, and re-connect it to your smart device. If symptoms persist, contact Hologic.

Audible Notifications

The following table defines the audible indicators the Viera™ Portable Breast Ultrasound emits:

Sounds	Meaning
1 short beep	Wi-Fi Network connected
2 short beeps	Wi-Fi Direct enabled
2 quick beeps	Scanner components are ready
3 quick beeps	Bluetooth is ready
2 tone-increasing pitches	Power on
2 tone-decreasing pitches	Power off
1 beep every few seconds	Critically low battery

4 long alerts	Embedded processor is preparing for software update
4 short beeps	No network connected
4 quick beeps	App Find Request (based on selected ringtone)
8 long alerts	App Find Request (important)

Sleep Mode

Sleep mode turns off the display on your smart device while pausing all current functions. This is to help save the Viera™ Portable Breast Ultrasound's battery power when the Clarius App is not in use.

After five minutes of dormancy (no live scanning), the Clarius App displays a 30-second countdown. You have the following options:

- Doing nothing will let the Viera™ go to sleep. The connection status area displays  and the live imaging page is in freeze mode.
- Selecting Cancel prevents the Viera™ from entering sleep mode.

▼To wake up the Viera™ Portable Breast Ultrasound:

- Unfreeze the live imaging page.
- Return to the Scanners page and re-select the scanner.

Auto Shutdown

If there is no connection between the Viera™ Portable Breast Ultrasound and the Clarius App (e.g. you signed out of the Clarius App but left the Viera™ running), the scanner automatically turns off to save battery power.

Scanner Locator

If you have misplaced the Viera™, the Clarius App can signal the Viera™ Portable Breast Ultrasound to emit an audible response.

▼To locate your Viera™ Portable Breast Ultrasound:

Go to the Settings menu and select the Identify button. You will hear an audible sound.

Using the Viera™ Portable Breast Ultrasound

3

This chapter explains how to install and use your Viera™ Portable Breast Ultrasound safely and effectively.

Refer to *Safety* on page 89 before handling the Viera™ Portable Breast Ultrasound.

Your Viera™ Portable Breast Ultrasound is already activated and ready for use. You just need to download the Clarius App on an Apple iOS device or an Android™-based device.

Downloading the Clarius App

Apple iOS

You must have an iTunes account and create a password.

1. On your smart device, go to www.apple.com/ca/itunes/

This opens the iTunes website.

2. Search for the Clarius App.

If you cannot find the Clarius App, your smart device may not be meeting minimum specifications. See *System Requirements* on page 18.

3. Tap the Install button and follow the instructions on your screen.

This downloads the application.

4. Tap the Open button.

This opens the Clarius App.

Note: Restoring factory settings on your iOS device deletes the Clarius App from your home screen. If this occurs, reinstall the Clarius App.

Android™

The Clarius App is available from the Google Play Store, a Google-operated digital media store where you can download applications for your smart device. Before installing the Clarius App, make sure your smart device meets the minimum requirements.

You must have a Google account and create a password.

1. On your smart device, go to <https://play.google.com>

This opens the Google Play Store.

2. Search for the Clarius App.

If you cannot find the Clarius App, your smart device may not be meeting minimum specifications. See *System Requirements* on page 18.

3. Tap the Install button and follow the instructions on your screen.

This downloads the application.

4. Tap the Open button.

This opens the Clarius App.

Updating the Viera™ Portable Breast Ultrasound

Software Updates

When an app update becomes available, you will receive an email notification.

▼To update the software:

1. Open the message and tap **Download & Install**.
2. Tap **Install** and follow the instructions on the screen.

Firmware Updates

If a Viera™ software update is required, the Clarius App will notify you.

▼To update the firmware:

1. Tap **Update**.

During the updating process, do not remove the battery. If the battery level is too low, the system will decline the update.

During the update, the Viera™ emits a purple flashing light. Also, a purple indicator displays at the top right of the screen. Once the update is complete, the Viera™ light turns blue.

2. Reconnect to the Viera™ Portable Breast Ultrasound's Wi-Fi Direct network.

Inserting & Removing the Battery

If the battery is low or empty, recharge it by following the instructions on *Recharging Batteries* on page 72.

Inserting the Battery

▼To insert the battery into the Viera™ Portable Breast Ultrasound:

1. Make sure that the battery contacts are facing downward and that the battery label is facing the Viera™.
2. Slide the battery into the Viera™ until it locks into place.

When the battery contacts are detected, the Viera™ will emit a sound.

Removing the Battery

▼To remove the battery from the Viera™ Portable Breast Ultrasound:

1. Pull back on the latch located at the top of the Viera™.

This unlocks the battery.

2. Slide the battery out of the Viera™.

Turning the System on & off

Starting the Clarius App



Before you begin using the Viera™ Portable Breast Ultrasound, make sure you have the Viera™, and also your smart device with the Clarius App installed on it.

▼To open the Clarius App on your smart device:

Go to your smart device's home screen and tap .

The Clarius App opens to the sign-in screen.

Next, you can select a scanner.

Exiting the Clarius App

To turn off the system:

- Close the Clarius App by swiping the screen up.
- Disconnect from the Wi-Fi.

If you close the Clarius App without ending the exam, the system pauses the exam.

Signing in & out

Signing in

When you open the Clarius App, it displays a sign-in screen for your user ID and password.

Signing out

▼To sign out:

1. Select the Sign Out menu option.
2. Select **Yes**.

If you want to remain signed in, select No.

Connecting Your Smart Device to Viera™

If the active Viera™ reaches its maximum idle time, the Clarius App disconnects your smart device from the Viera™, making the Viera™ available to other smart devices. To set the maximum idle time, see *Settings* on page 23.

Connecting Apple iOS Devices to Scanners

▼To connect your Apple iOS device to a Viera™ Portable Breast Ultrasound:

1. From the Scanners page, tap the image or the name of the Viera™ Portable Breast Ultrasound you want to select.

This activates the selected Viera™ and attempts to connect it to your smart device's Wi-Fi. When the Viera™ emits an audible beep and its light flashes blue, the Wi-Fi Direct is enabled. When you hear another audible beep and the scanner light turns solid blue, the Viera™ is ready for Wi-Fi connection.



If the status light shows nothing (empty battery), or it is orange (low battery), recharge the battery.

Once the checkmark appears in the status circle, the Clarius App displays the name of the selected Viera™ Portable Breast Ultrasound's Wi-Fi network and the password. Remember the network name. The Clarius App has copied the password, so you do not need to memorize it.

2. Go to your smart device's Settings page, select the Wi-Fi section, and tap on the name of your Viera™ Portable Breast Ultrasound's Wi-Fi network. This automatically pastes the password in the field (this happens in the background).
3. Return to the Clarius App.

The status light on the selected Viera™ turns blue, indicating its connection to your smart device. All other Viera™ Portable Breast Ultrasounds remain in standby mode.

Workflows that apply to the selected Viera™ become enabled.

Next, select a workflow. For information, see *Starting New Exams* on page 44.

Connecting Android™ Devices to Scanners

▼To connect your Android™ device to a Viera™ Portable Breast Ultrasound:

1. From the Scanners page, tap the image or the name of the Viera™ you want to select.

This activates the selected Viera™ and attempts to connect it to your smart device's Wi-Fi. When the Viera™ emits an audible beep and its light flashes blue, the Wi-Fi Direct is enabled. When you hear another audible beep and the scanner light turns solid blue, the Viera™ is ready for Wi-Fi connection.



If the status light shows nothing (empty battery), or shows orange (low battery), recharge the battery.

2. Once the checkmark appears in the status circle, tap **Connect** to link Wi-Fi Direct to the Viera™ Portable Breast Ultrasound. This takes you to the Wi-Fi Settings.
3. Select the Viera™ Portable Breast Ultrasound's Direct Wi-Fi name. You need the Viera™ Portable Breast Ultrasound's Wi-Fi password the first time you connect. You can paste to enter it.

It will ask if you allow Clarius to access your location. Select either **Never** or **While Using**.

4. Press **Join**.
5. At top-left choose **Back to Clarius**. If the Clarius App has been updated since you last signed in, the system will prompt you to update your Viera™ Portable Breast Ultrasound software.

The status light on the selected Viera™ turns blue, indicating its connection to your smart device. All other Viera™ Portable Breast Ultrasounds remain in standby mode.

Workflows that apply to the selected Viera™ become enabled.

Next, select a workflow. For information, see *Starting New Exams* on page 44.

Managing Exams



- Notifications and alerts from third-party applications may interrupt you or the Clarius App, thereby interfering with the exam. Configure your smart device in accordance with your institution's security policies.
- Vibration range that is too high for the scanner may cause the scanner to malfunction during an exam.
- Using improper gel type or combining different gel types may expose patients to risks and produce poor-quality images.

For proper transmission of the acoustic beam, use only Aquasonic 100, and use it only before its expiry date. Download the usage instructions from www.parkerlabs.com/ and read all the information before operating the device.



Do not use:

- Lotion-based products or gels that contain mineral oil.
- Hand-sanitizing gels.
- Scanners left soaking in gel.

Starting New Exams

Before you begin a new exam, make sure you have selected a Viera™ Portable Breast Ultrasound. For information on selecting a Viera™ Portable Breast Ultrasound, see *Connecting Your Smart Device to Viera™* on page 42.

▼To begin a new exam:

From the Workflows page, select one of the following workflows:

- Breast
- Dense Breast
- Interventional

The Clarius App displays the last-used workflow at the top of the screen.

Once you have selected a workflow, you can enter the patient's information. See *Entering Patient Information* on page 46.

Pausing an Exam

If there is data entry that requires no patient presence (for example, performing measurements on captured images), you can mark the exam as incomplete by pausing it, and return to it later to continue.

An exam is paused when you:

- Exit the Clarius App.
- Tap  to return to the home screen.

Ending an Exam

Once you have finished entering your impressions, you can end the exam. Once you end an exam, it is marked as complete, and you cannot re-open or resume it.

▼To end the exam:

From the Impressions page, tap **End Exam**, then select one of the following options:

- **Discard:** This permanently deletes the current exam, including all images. The Clarius App takes you to the Workflows page for selecting another exam type.
- **Submit:** This ends the exam and marks it as complete, even if you have not provided all the information on the worksheet, and prepares it for export to the Clarius Cloud. The Clarius App places the images in queue to upload to your Clarius Cloud account the next time network connection is made.
- **Cancel:** This cancels the action so that you can continue the current exam.

Resuming a Paused Exam

When you return to this exam, you can no longer continue imaging, but all other pages are accessible.

▼To continue an in-progress exam:

1. Go to either the Scanners page or the Workflows page.

2. Tap .

3. Select **Open Exam**.

The application takes you to the Patient Demographics page.

To discard an in-progress exam, select **End Exam**.



Managing Patient Information

Entering Patient Information

Once you have selected a workflow, you will see the Patient Demographics page.

Before you begin scanning, enter the fields provided.

▼To enter patient information:

1. Tap a field to display .
2. Tap  to display the Barcode page.
3. Align the patient's barcode within the frame.

When the Clarius App captures the barcode, it will return to the Patient Demographics page, and display the patient's information in the fields.

Alternatively, you can enter patient information manually.

When you have entered all required patient information, tap  to go to the next page to populate the indications. For information on populating indications, see *Populating Indications* on page 46.





Populating Indications

The Indications page contains a series of checkboxes or fields to indicate the reasons for the examination.

When you have entered all the indications, tap  to go to the next page to begin imaging. For information on imaging, see *Imaging* on page 53.

Selecting Scanning Modes



▼To select a mode:

1. From the imaging screen, tap .
2. Select from one of the following options:
 -  B-Mode imaging
 -  Color Flow Imaging (i.e. Color Doppler)
 -  Power Doppler Imaging (i.e. Power Doppler)
 -  M-Mode imaging

B-Mode

When you start an exam, it defaults to B-Mode (brightness mode). Sometimes referred to as 2D Mode, this two-dimensional imaging mode displays in grayscale.

▼To view the image in B-Mode:

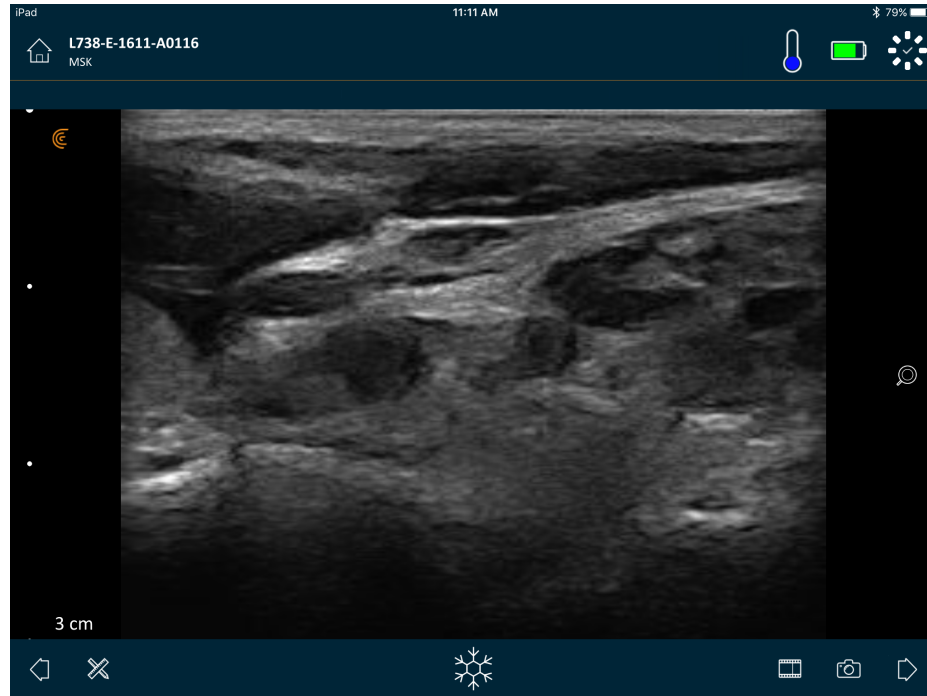

Tap , and then .



Color Doppler

This scanning mode estimates the average velocity of flow within a vessel by color-coding the information. The direction of blood flow toward and away from the ultrasound transducer is represented by red and blue.

▼To view the image in Color Doppler:

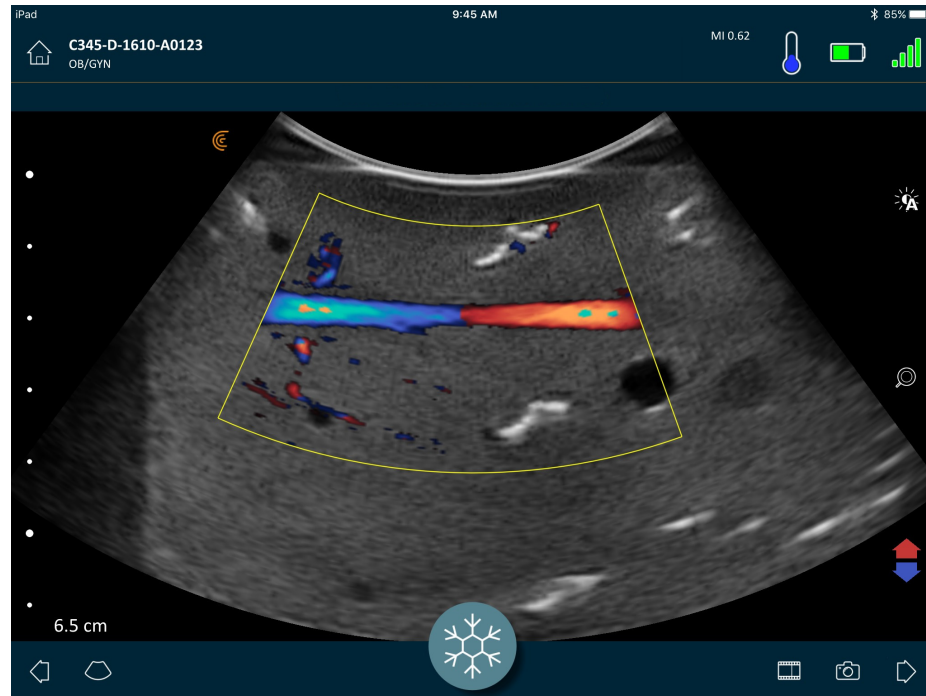

Tap , and then .



▼To reverse the flow colors:

Tap .

▼To view the image in normal or slow speed:

1. Tap  to display a list of options.
2. Tap  to view in slow speed.
3. Tap  to return to normal speed.

▼To resize the yellow frame:

1. Drag the yellow frame to display arrows.
2. Press and hold , then drag it vertically or diagonally.

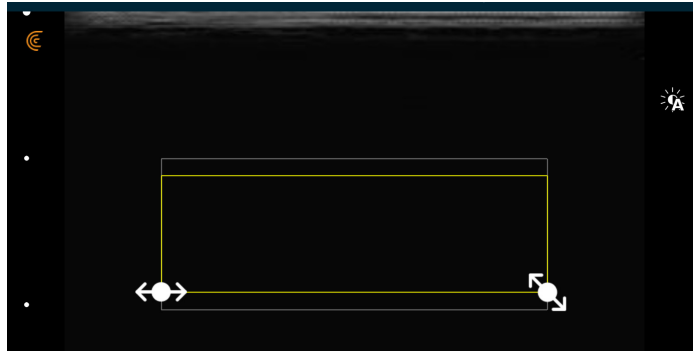

▼To reshape the yellow frame:

1. Drag the yellow frame to display arrows.
2. Press and hold , then drag it horizontally.

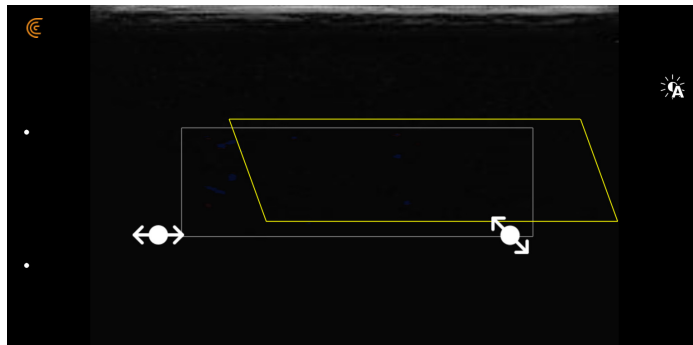

▼To move the yellow frame:

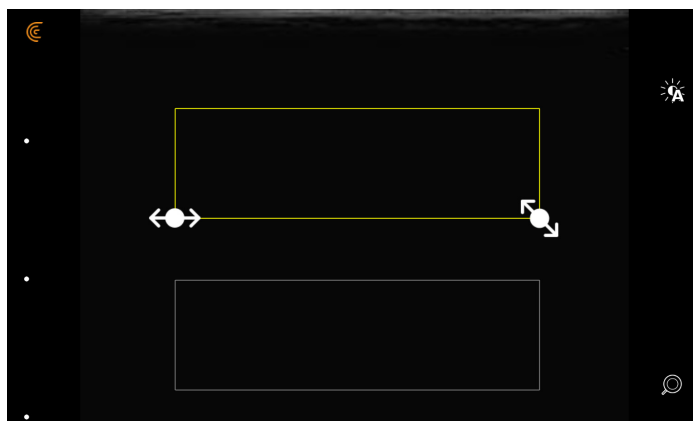

Drag the yellow frame to a new location.



Power Doppler

This scanning mode is used to obtain images that are difficult to acquire with standard color Doppler. It provides greater detail of blood flow, especially in vessels that are located inside organs. Power Doppler is more sensitive than color Doppler for the detection and demonstration of blood flow, but provides no information about the direction of flow.

▼To view the image in Power Doppler:

Tap  and then .

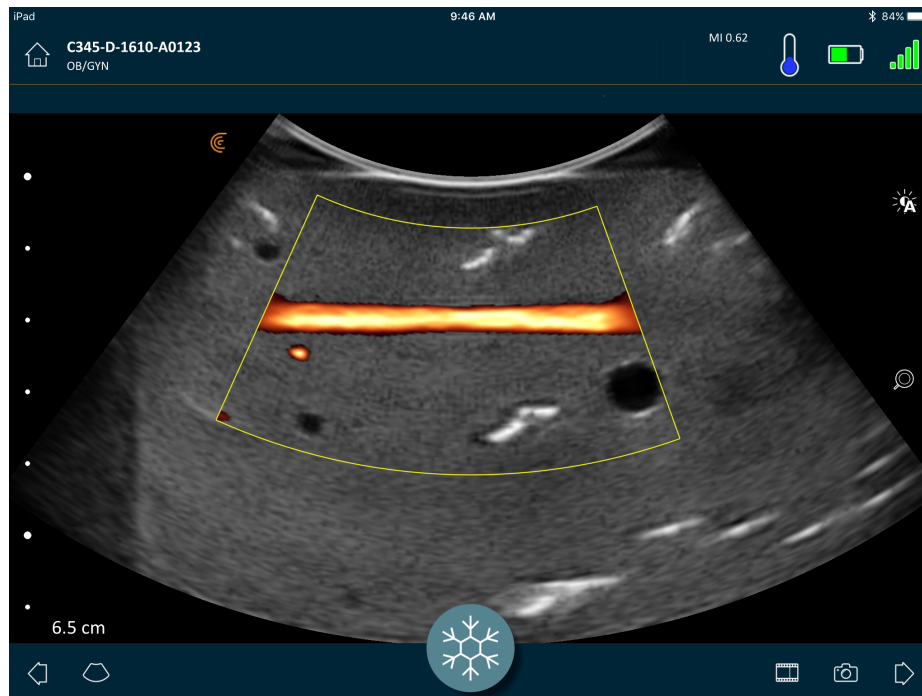



You can re-size, re-shape, and move the area of interest the same way as you would in Color Doppler mode. For more information, see *Color Doppler* on page 48.

M-Mode

This scanning mode determines the velocity of specific organ structures by using quick-succession pulses on a single line in B-Mode imaging. In ultrasound, this is the equivalent of a video.

▼To view the image in M-Mode:

Tap  and then .

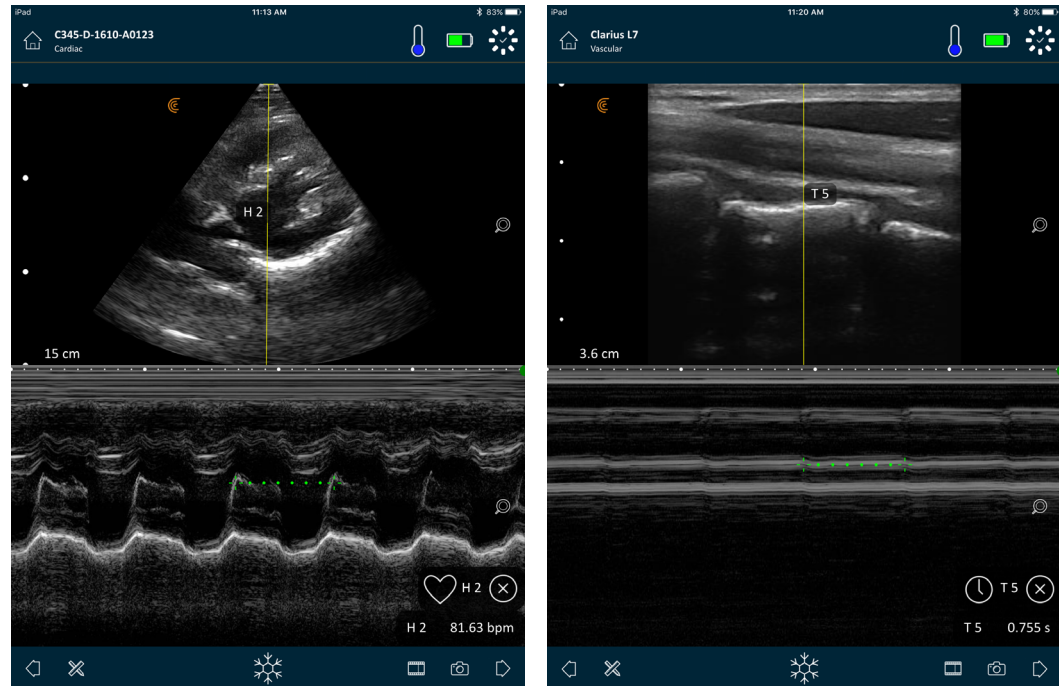

The M-line appears over the image. You can adjust its placement before adding the spectrum.

▼To adjust the line placement:

Tap and hold the line, then drag.

When you release the line, the spectrum displays on the screen.

If you hold the smart device in portrait mode, the image displays above the spectrum. If you hold the smart device in landscape mode, the image displays to the left of the spectrum.



Imaging

Adjusting Gain

Turning Auto-Gain on & off

The system selects the auto-gain mode by default. When auto-gain is turned on,  is displayed on the screen. Auto-gain automatically adjusts the gain of B-Mode images by detecting the noise floor and signal strength in the image. You can turn off auto-gain and adjust the gain manually.

▼To toggle auto-gain on and off:

Tap  and then .



If you find that some images on auto-gain mode appear too bright or too dark, you can adjust the gain.

▼To adjust the gain on auto-gain mode:

1. Drag anywhere on the screen.

This displays a vertical line down the center of the screen.

2. Slide the bars left and right to adjust the gain.

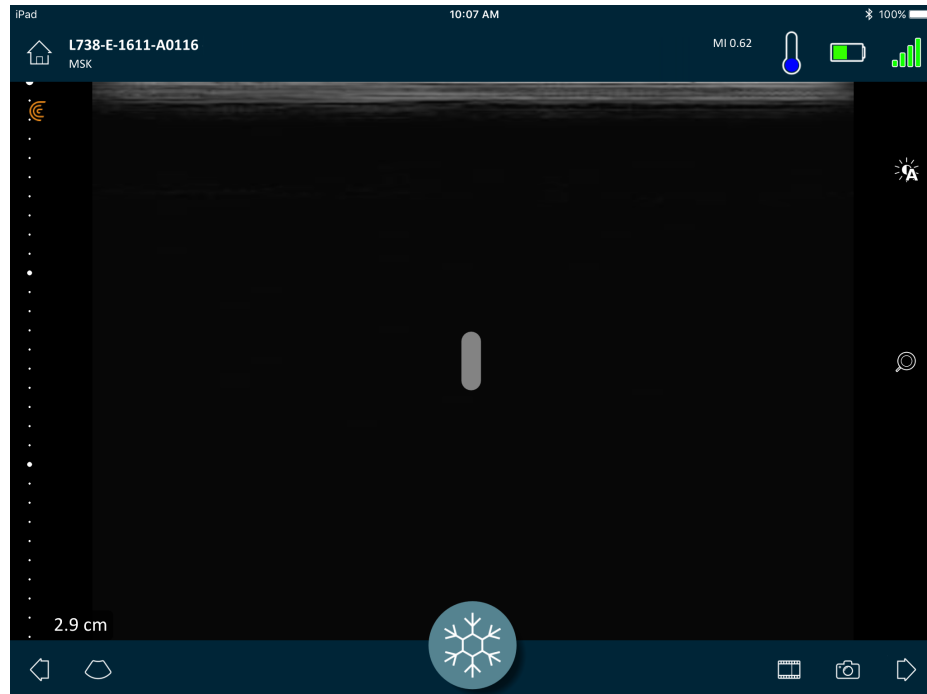

Manually Adjusting Gain

▼To manually adjust gain:

1. Make sure auto-gain is turned off.

If you see , you have auto-gain turned on. To turn it off, see *Turning Auto-Gain on & off* on page 53.

2. Drag anywhere on the screen.

This displays three vertical lines down the center of the screen.

3. Slide the bars left and right to adjust the gain.

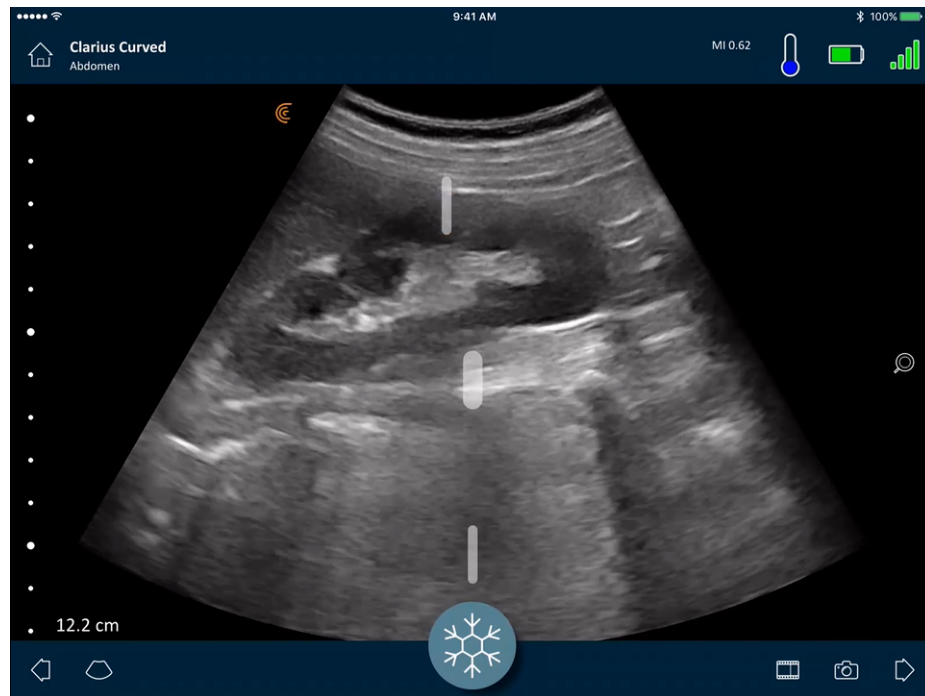



Saving the image retains the gain adjustment.

Using the Center Line

The center line tool is a dotted vertical line displayed down the center of the imaging screen. It can be used, for example, to guide the needle's location during needle guidance procedures.

▼To show the guidance tool:

1. Make sure you are in live imaging mode. This enables the tool icon.
2. Select  and then . The center line displays.

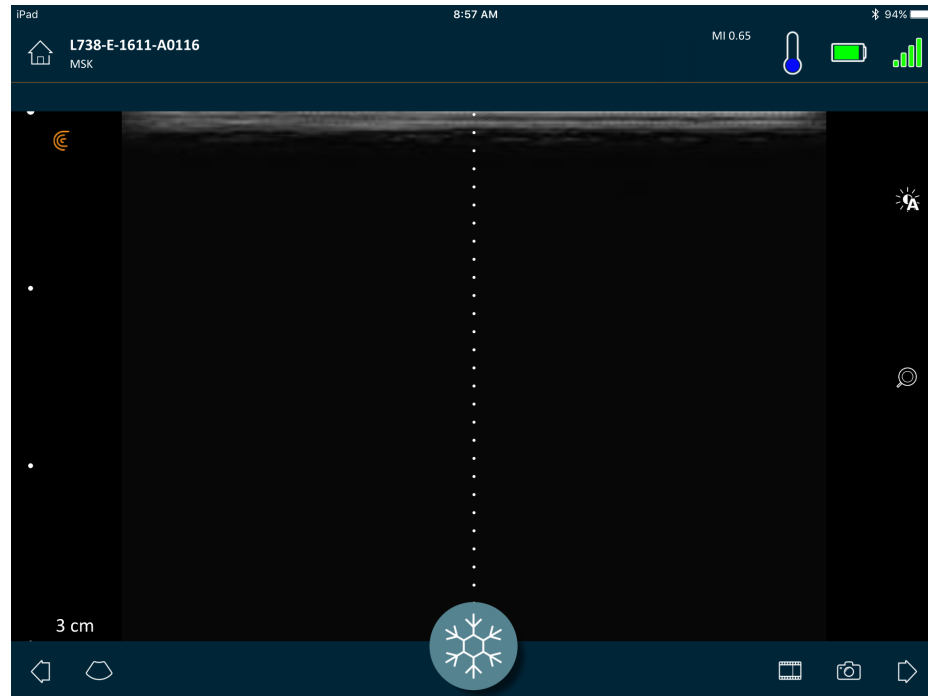



▼To remove the guidance tool:

- Repeat the steps for displaying this tool.
- Freeze the imaging screen.

Using Needle Enhance

If you are using a linear scanner, the Needle Enhance feature is available in the tools list. Using this feature highlights the needle inside the tissue and displays it in grayscale.

▼To use the Needle Enhance feature:

1. From the imaging screen, tap .
2. Tap .

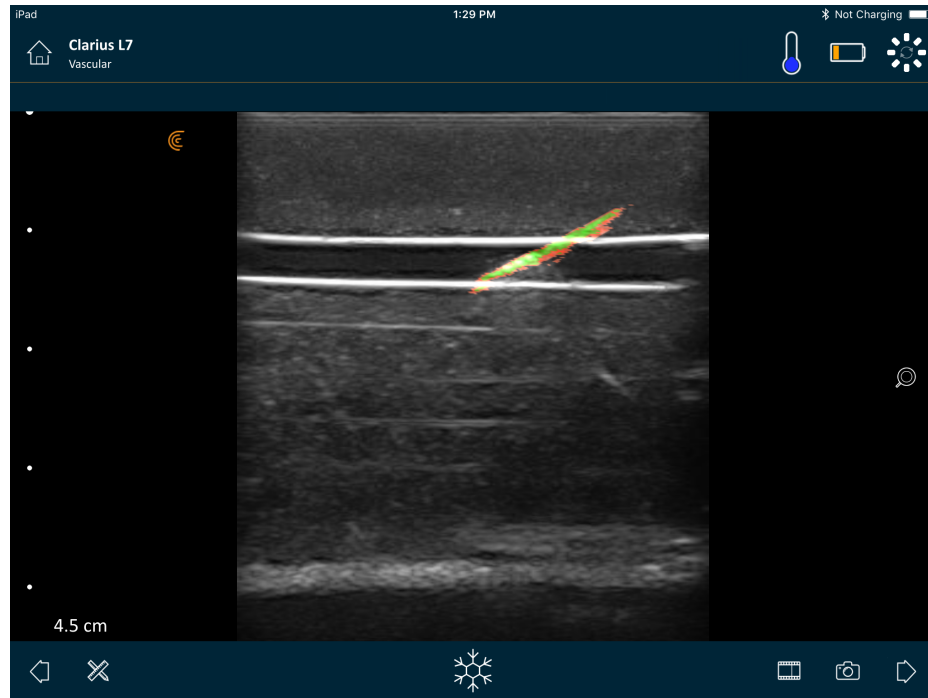

Using Automated Heart Rate

The automated heart rate feature is available in the cardiac workflow. When you scan the heart, it automatically detects and measures the heart rate.

▼To use the automated heart rate feature:

1. Start a new exam and select the cardiac workflow.

For instructions on starting new exams, see *Starting New Exams* on page 44.

2. Go to the imaging page and begin scanning.

When the Viera™ Portable Breast Ultrasound detects the heart rate, it displays it on the screen.

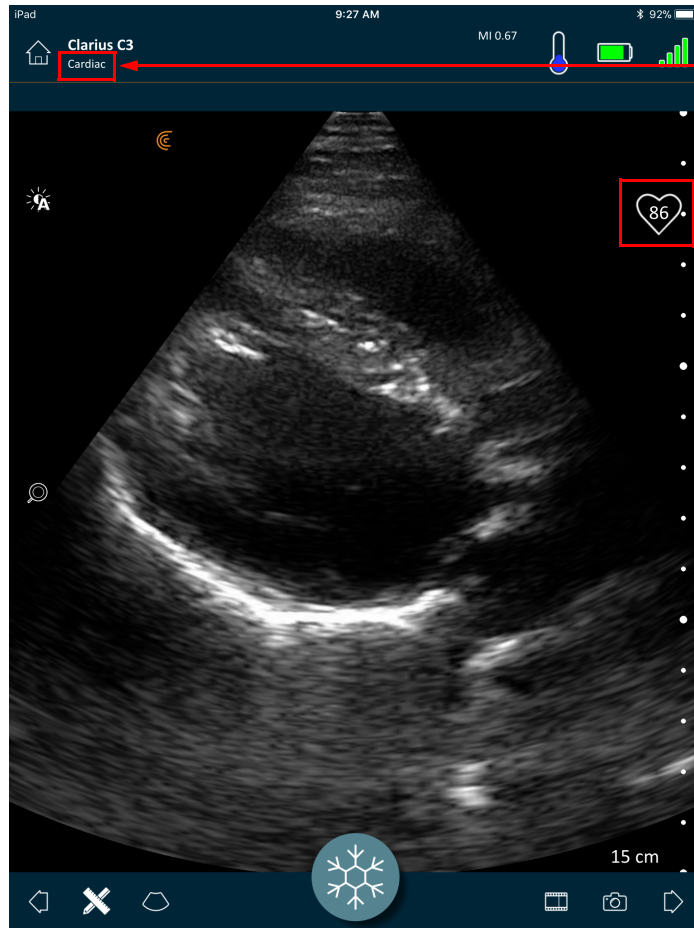

Select the cardiac workflow.

When the Viera™ Portable Breast Ultrasound detects the heart rate, it displays it on the screen.

Freezing/Unfreezing Cine Loops

A cine loop is a sequence of still images presented in the form of a video. By default, the system retains the last 20 seconds of the imaging session. When you freeze an imaging session, you can scroll back and review these frames.

▼To freeze the cine loop:

During live imaging, tap .

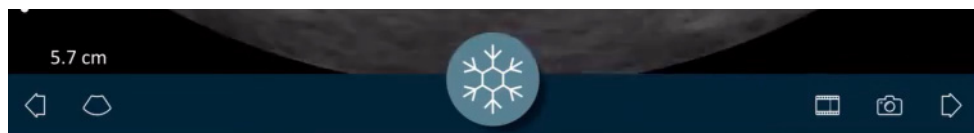

This pauses the cineloop. The icon decreases in size, the Viera™ Portable Breast Ultrasound changes to standby mode, and the light turns blue.

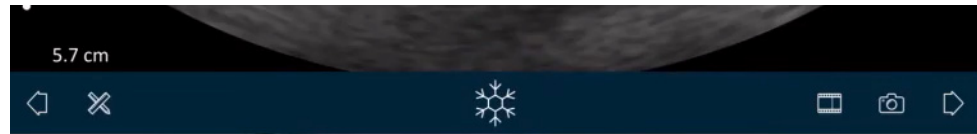

When you freeze a cineloop, you can:

- Add annotations. For instructions, see *Using Annotations* on page 64.
- Make measurements. For instructions, see *Using the Measuring Tools* on page 67.
- Save the currently displayed image. For instructions, see *Saving Images* on page 61.

If the Viera™ Portable Breast Ultrasound detects no activity for 30 seconds, it changes to standby mode and the Clarius App freezes the live imaging screen. You can disable this feature so that after 30 seconds of inactivity, the Viera™ Portable Breast Ultrasound remains in scanning mode and the Clarius App continues imaging.

▼To disable auto-freeze:

Press and hold .

The icon turns green.



The auto-freeze feature is now disabled. After 30 seconds of inactivity, the Clarius App continues imaging unless you manually freeze it.

▼To enable auto-freeze:

- Press and hold  until it turns blue.
- Start a new exam.

Capturing Cineloops & Images

When you have finished capturing your cineloops and images, there is no need to manually upload them to the Clarius Cloud. When you disconnect your smart device from the Viera™ at the end of the scanning session, your smart device reconnects to the network and automatically uploads them to the Clarius Cloud. You can then sign into the Clarius Cloud to view them.

Saving Cineloops

▼To record a cineloop:

1. During live imaging, tap and hold  to display a list of options.
2. Select time length.

You can record 3, 5, 10, 20, or 30 seconds of live imaging.

3. Tap  again to begin recording.

During the live-image recording, a counter displays beside the icon. When the counter disappears, the recording is saved.

▼To edit the length of the cineloop:

1. Record a cineloop.

When you capture a cineloop, the Clarius App displays a horizontal scroll bar at the bottom of the screen. This scroll bar remains visible for three seconds. To display it again, slide your finger along the bottom of the screen.

2. Use the two dots to scroll through the cineloop.

The left dot lets you scroll from the beginning of the cineloop. The right dot lets you scroll from the end.

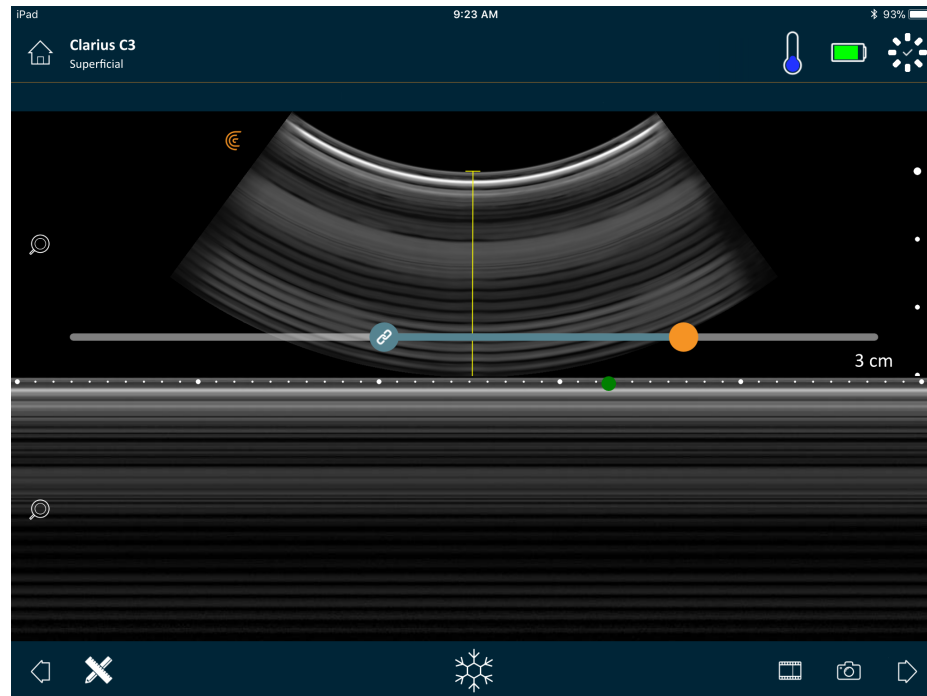

To activate a dot, tap on it. When it turns from blue to orange, slide it along the horizontal scroll bar.



3. Once you have marked the desired range, double-tap  to save this.

The Clarius App saves both the original capture and the edited capture.

Saving Images

1. During live imaging, tap .
2. Slide your finger along the horizontal scroll bar to view the sequence of still images from the recorded cineloop.
3. Find an image you want to save.
4. Tap .

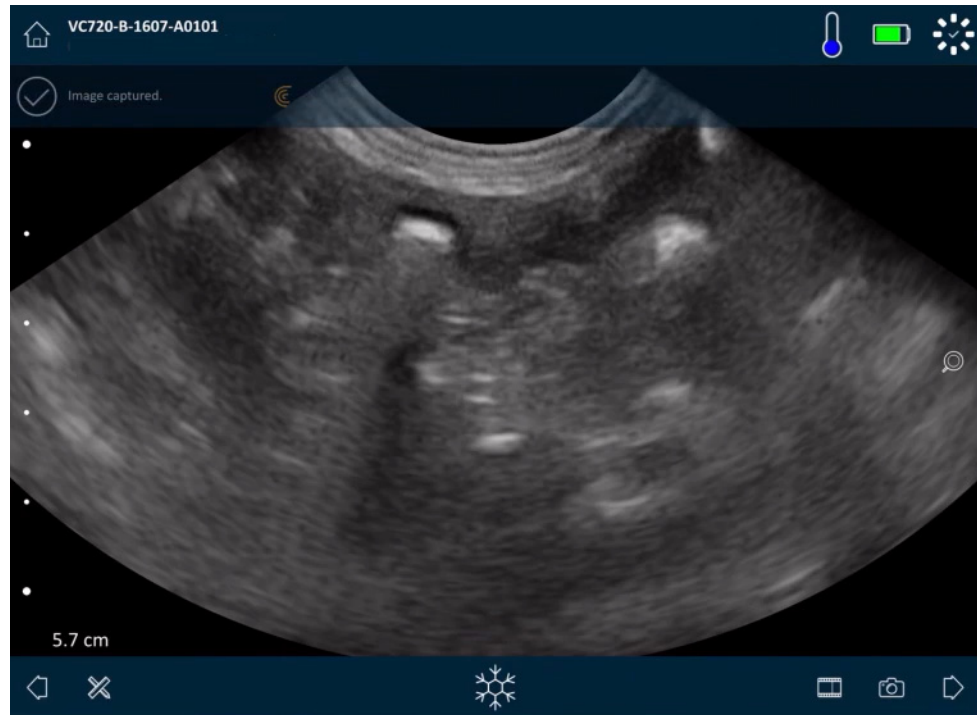

Zooming in & out

▼To expand (zoom in) an area of the image:

Spread the image.



Alternatively, tap  and drag up to the plus sign (“+”).

▼To reduce (zoom out) an area of the image:

Pinch the image.

Alternatively, tap  and drag down to the minus sign (“-”).

▼To return to default zoom:

Tap  and drag to .

▼To pan or move the magnified image:

Tap the image and drag it.

Changing Depth

While live imaging, you can adjust the depth of the scan.

▼To change depth:

1. Make sure you are using B-Mode and default zoom.
2. Drag your finger up and down the left vertical bar to increase and decrease the depth.

The screen displays a depth scale, in centimeters. The increments of the scale depend on the depth and size of the display.

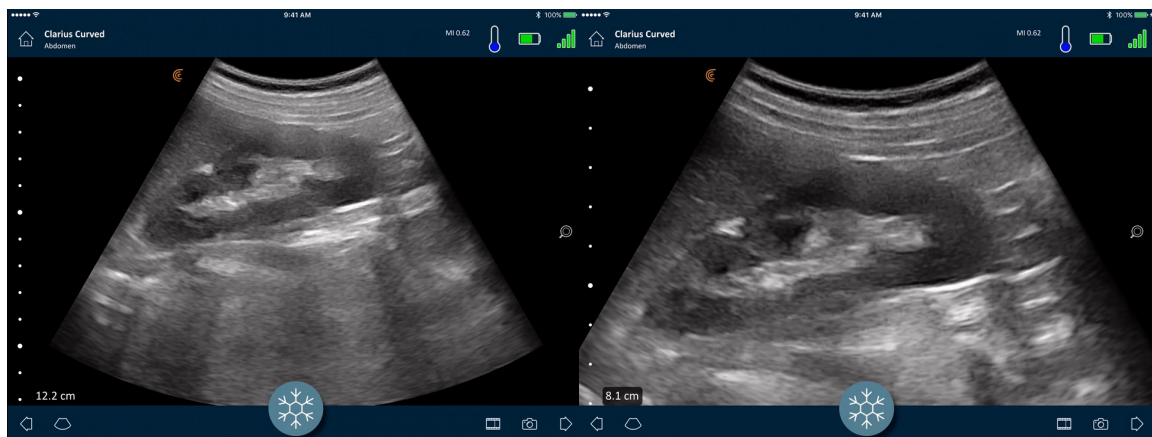

Rotating Images

You can rotate an image on its axis to view the image from a different angle.

▼To rotate the image:

Press and hold , and then drag it.

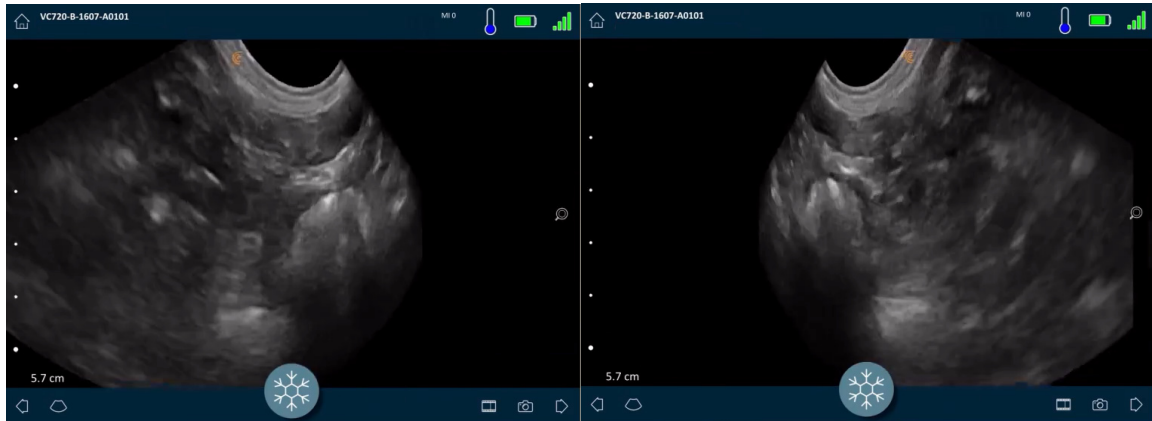

Using Annotations

Labeling Images

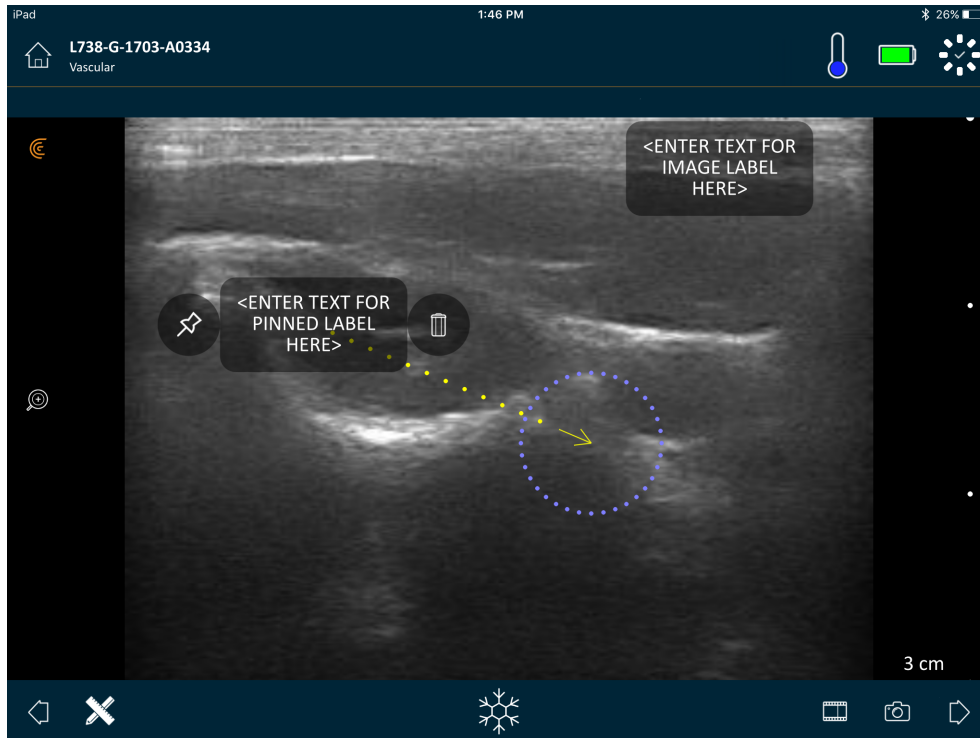

To identify specific objects, or to describe an entire image, you can add text labels on the imaging screen. There are two main types of text labels:

- Image label: Text referring to the entire cineloop or image, placed in one of the four corners of the imaging screen. Image labels remain visible when uploaded to the Clarius Cloud.
- Pinned label: Text referring to an area of interest, placed close to the object. You can draw arrows to mark a specific point on the object. Pinned labels are removed when the images are uploaded to the Clarius Cloud.



You can create labels either before or after capturing the image.

▼To create a label:

1. Tap  and select .

The screen displays a text field.

2. Enter text and tap . Alternatively, press the Enter key.

Note: To create multiples labels, tap .

The label defaults to an image label and is placed in the corner of the screen. To change this to a pinned label, drag the label to an area of interest, then drag the  to draw an arrow to a specific point on the object. You can draw multiple arrows to different points on the image. If you drag the pinned label to a different location on the image, the arrow remains anchored to the location you placed it.

The following table summarizes the labels' behavior when used with the various imaging tools.

Action	Image Label	Pinned label
Zooming in and out	Zooming in/out has no effect on image labels. They are retained in the corner of the view.	Zooming in/out retains pinned labels on the objects. If the object is outside the view, the label displays along the closest edge of the screen, and arrows remain attached to the off-screen image.
Freezing and unfreezing	Image labels you create during live imaging remain visible when you freeze the image.	You must freeze the image to pin a label to an object. When you return to live imaging, the pinned label is removed.
Applying labels to a cineloop	Image labels you create in a cineloop are retained in the corner of the view, even when you scroll through the frames.	Pinning a label to a specific object in a cineloop displays the label in that frame only.

Using Pictograms

Use pictograms (symbols resembling objects you are scanning) to represent specific areas of the body that you are scanning, and to illustrate the placement and angle of the Viera™ Portable Breast Ultrasound on the body. Pictograms give reviewers quick references on how you scanned a body part.

▼To apply a pictogram to an image:

1. Tap  to display a list of tools, then select the pictogram icon.

The Pictogram screen displays.

2. From the screen, select a diagram.

You can rotate the selected diagram as you would rotate an image. For instructions on rotating images, see *Rotating Images* on page 63.

3. Drag the scanner diagram to an area.

You can rotate the scanner diagram by touching the screen with two fingers and rotating them.

4. Select the checkmark icon.

This takes you back to the imaging screen and displays the pictogram. You can move this pictogram anywhere on the screen.

When you capture the image, the pictogram is also saved.

Using the Measuring Tools





Measurements can be made using B-Mode.

To make measurements, tap  to display a list of tools, then select from the options.

When you tap to mark your points on the screen, the system displays a green cross with a surrounding purple circle. If you want to move the end points to a more accurate location on the image, apply your finger on the purple circle and drag it to move the end points. Do not place your finger directly on the green crosses, as this obstructs the view of the end points, making it difficult to accurately relocate them.

A 2D distance measurement uses two calipers to measure the length of a straight line between two points. You cannot magnify an image while using the 2D distance measuring tool. When you unfreeze the image or end the exam, the system removes the measurements from the image. To retain the measurement, save the image.

Common Measuring Tools

-  Single measurement: Tap on an area to mark the first point, then tap on another area to mark a second point. This creates a distance line between the two points. If you are measuring bladder volume, you can select from a variety of pre- and post-void measurements, and the Clarius App automatically calculates the volume using the formula: $(\pi/6) \times \text{length} \times \text{width} \times \text{height}$.
-  Dual measurement: Tap on an area to mark the first point, then tap on another area to mark a second point. This creates a distance line between the two points. You can create a maximum of two trace distances per image.
-  Trace: Press and hold an area, then drag in a circle. This draws a circumference.
-  Ellipse: Tap on an area to mark the first point, then tap on another area to mark the second point. The application marks two additional points to create a circle.
-  Single vertical measurement: Tap on an area to mark the first point, then tap on another area to mark a second point. This creates a vertical distance line between the two points.

Measurement Accuracy

You can use the ultrasound system to make measurements on ultrasound images. The measurements are then used with other clinical data to make a diagnosis.

Never make a diagnosis based solely on measurements. When quantifying data, consider other factors. The accuracy of each measurement is highly dependent on image quality, which in turn is highly dependent on system design, operator scanning technique, familiarity with system controls, and patient echogenicity.



You are responsible for image quality and diagnosis. Ensure that the data used for inspection and diagnosis is sufficient, both spatially and temporally, for the measurement method.



Selecting an incorrect or hazardous imaging mode may deliver excessive acoustic energy to the patient during the exam.

Measurement Accuracy Table

Each figure below is derived from the sum of all parts of the Viera™ Portable Breast Ultrasound.

2D MEASUREMENT RANGE & ACCURACY

Measurement	Relative Error	Minimum Range	Maximum Range
Axial Distance	< ± 2%	≤ 0.2 mm	≥ 30.0 cm
Lateral Distance	< ± 2%	≤ 0.2 mm	≥ 30.0 cm



Inaccurate measurements or misinterpretation of results taken from an exam may lead to misdiagnosis.

Using the View-Sharing Mode

Before you begin using this feature, make sure that:

- All smart devices you are using for the current listening session are running on the same version of the Clarius App.
- The Clarius App's camera feature is turned on. To do this, go to your smart device's Settings page, select the Clarius App, and turn on the camera.

If using an Android™ device, disable cellular data before you begin.

▼To use the view-sharing mode:

1. Go to the first device (we'll call this the "scanning device") and sign into the Clarius App using your sign-in credentials.
2. Connect the scanning device to a Viera™ Portable Breast Ultrasound using Wi-Fi Direct network.
3. Select the Clarius Cast menu option.

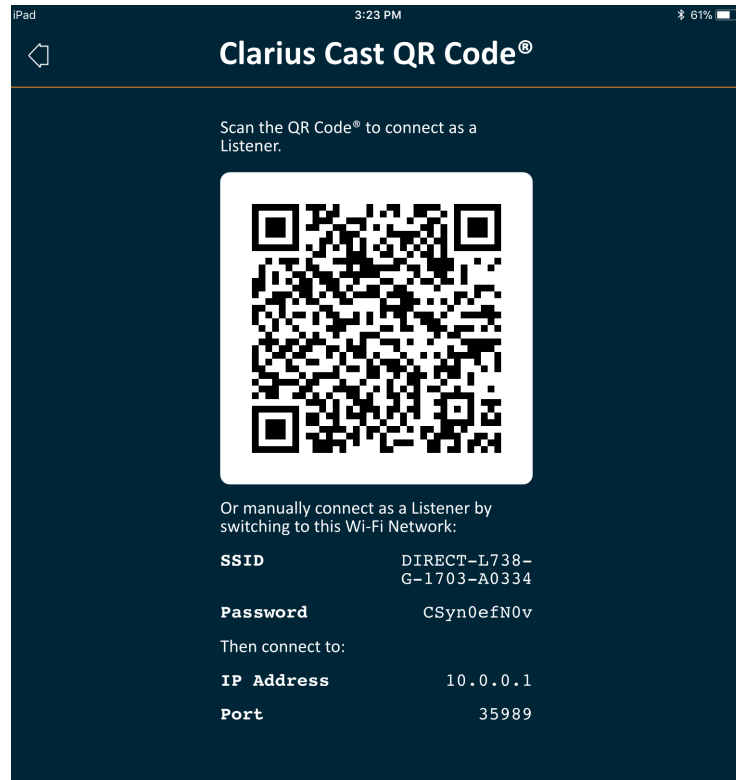

4. Go to the second device (we'll call this the "listening device").
5. Go to the main menu and select the Clarius Cast option to display the Scan QR Code® page.

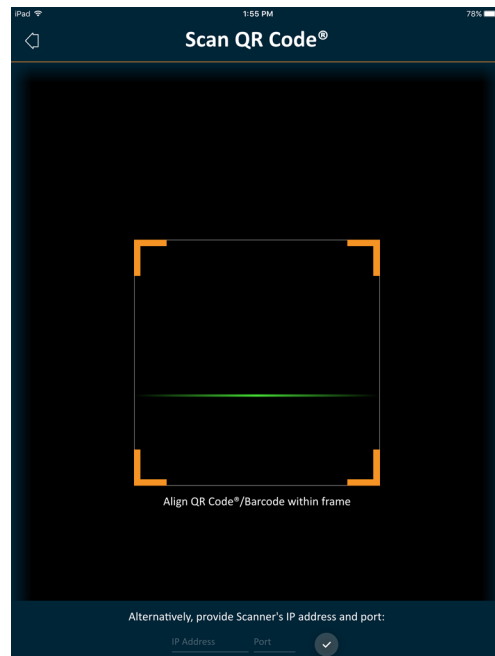

6. Align the scanning area with the QR Code of the driving device. The frame can be adjusted by dragging the corners. The driving device automatically captures the QR Code.

The listening device can zoom into a scanned image, but cannot perform any other action. When the driver disconnects their smart device from the Viera™ Portable Breast Ultrasound, the listener device also disconnects from that scanner.

Using Chromecast™

For information about Chromecast, go to:
https://store.google.com/magazine/google_cast_platform_story

For instructions on connecting your Clarius App to your TV, go to:
<https://support.google.com/androidtv/answer/3006709?hl=en>

Review Findings

When you have finished imaging, you can evaluate and edit the findings acquired during the exam.

Reviewing Cineloops & Images

- ▼To view cineloops and images during an exam:

Go to the Review section.

- ▼To view thumbnail images and videos:

Swipe left and right, or up and down.

Deleting Items

You can delete unwanted images and cineloops from the Review page by tapping  next to the item.

When you are done reviewing, tap  to go to the next page of the application to populate impressions. For information on populating impressions, see *Populating Impressions* on page 71.

Populating Impressions

Once you have reviewed the images, record your findings from the exam.

Once you have entered your impressions, you can end the exam. For information on ending the exam, see *Ending an Exam* on page 45.

Exporting Exams

When you have finished an exam, you can export it using the following options:

- Upload the exam to the Clarius Cloud: When you end the exam and disconnect your smart device from the Viera™, the smart device reconnects to the network and automatically uploads the exam to the Clarius Cloud.
- Upload the images to a DICOM server. You can do this after you end the exam, when you select to submit it to the Clarius Cloud. Alternatively, you can go to the Exams page, select the exam from the list, and then select to upload it to a DICOM server. Before you use DICOM, read the DICOM statement at www.clarius.me/dicom/.
- Export to Local Media. This feature is available on iOS only. To send a copy of the scanned images or cineloops to your smart device's saved photos, upload the exam to the Clarius Cloud, then go to the Exams page and select the **Export to Local Media** option.

Maintenance

There is no recommended periodic maintenance required for the system, scanners, or accessories. There are no internal adjustments or alignments required. There are no functions that require periodic testing or calibration. The only maintenance required is to clean and disinfect the Viera™ Portable Breast Ultrasound and battery according to the instructions in *Cleaning & Disinfecting* on page 83.

Perform maintenance regularly and as needed. The system must be serviced by trained personnel only.



Failing to regularly maintain or verify the Viera™ Portable Breast Ultrasound may lead to undetected performance errors.

Hardware Maintenance

Testing Scanners

When you turn on the system, the scanner powers up and automatically tests its internal components. The Viera™ Portable Breast Ultrasound's LED will light up and you will hear a two-tone beep. The table below defines these conditions:

Battery Condition	Priority	Visual Indication	Audible Indication
Low battery	Low	Orange flashing status LED	None
Critically low battery	Low	Red flashing status LED	1 beep every few seconds

Also, the system runs a series of tests in the background. If your smart device is not connected to a wireless or cellular network, the logs are queued until you have network connectivity. For more information, please contact Hologic Technical Support.

Recharging Batteries

Because the Viera™ Portable Breast Ultrasound is battery-operated, you must recharge the battery when necessary. An empty battery takes approximately 1 ½ hours to fully charge. A full battery has approximately two hours of typical scanning time and can last up to two weeks in sleep mode.

The battery power level is displayed on the screen. When the battery reaches a level equal to under 10 minutes of residual scanning time, a visual warning is presented to the user. Battery warning notifications from Viera™ Portable Breast Ultrasounds in sleep mode via BLE are displayed to the user using the standard notification services of the smart device running the Clarius App.



When you receive your Viera™ Portable Breast Ultrasound, the battery is 30% charged. Charge the battery to 100% before use.



Connecting the battery charger to a power supply that is not manufactured by Clarius may have the incorrect voltage/current, which could damage the battery charger.



Charge the battery using only the specified charger.

If you turn on the Viera™ Portable Breast Ultrasound and leave it untouched, it will go through the following modes to help reduce temperature and battery power:

1. After three seconds, it decreases frame rate.
2. After 30 seconds of decreased frame rate, it freezes.
3. After 10 seconds in freeze mode, it goes idle.
4. After five minutes of idle time, it shuts down.

The battery has approximately 45 minutes of continuous scanning time and lasts approximately seven days in standby mode.



Do not charge the battery while on board any aircraft.



Charging the battery in a rotary-wing airborne ambulance may cause the battery charger's power supply to interfere with the aircraft's electrical system, causing a malfunction that could lead to failure of control, instrumentation, and communication systems.

▼To charge the battery:

1. Connect the line cord of the AC power adapter to an indoor electrical outlet.
2. Connect the AC power adapter to the receptacle on the battery charger.
3. Remove the battery from the Viera™ Portable Breast Ultrasound by following the instructions on *Removing the Battery* on page 40.
4. Insert the battery into a slot on the battery charger.

The charger displays the following status lights:

- Orange: Battery is currently charging.
- Green: Battery is fully charged.

Storing Scanners

To protect your Viera™ Portable Breast Ultrasound:

- Dry them thoroughly before storage.
- Avoid storing them in extreme temperatures.
- Avoid placing them under direct sunlight for prolonged periods of time. This will not impact the Viera™ Portable Breast Ultrasound's safety and performance but may discolor the housing's finish.
- Store them separately from other equipment.



The scanner may degrade in performance or become unusable if stored or transported in ambient temperatures below -20°C (-4°F) or above 50°C (122°F).

System Maintenance

Sending Activity Logs

Select the Support menu option to go to the Support page and select the Submit Logs button. This downloads logs from the Viera™ Portable Breast Ultrasound, then combines them with the logs from the Clarius App. This bundle is then sent to the Clarius Cloud where they can be retrieved by a Hologic Technical Support staff. The log files contain diagnostic information.

If the log files grow too large, you may want to delete them to save space on your smart device. To delete the log files, go to the Settings menu.

Help

Additional Training

If you require more training on the Viera™ Portable Breast Ultrasound, see the tutorials on www.clarius.me/category/education/.

Error Messages

The Viera™ Portable Breast Ultrasound displays no error messages. Instead, the Viera™ presents visual and audible notifications.

- For a list of visual notifications, see *Status Lights* on page 35.
- For a list of audible notifications, see *Audible Notifications* on page 35.

Need Help?

If you require additional assistance, you can do one of the following:

- Refer to the Clarius FAQ at www.clarius.me/faq/
- Please contact Hologic Technical Support.

Accessories



To order these additional accessories, contact your Hologic representative:

- Clarius Dock (CIDN 99-02-00025): This docking station combines a cooler (for up to three scanners) and a battery charger (for up to five batteries).
- Clarius Fan (CIDN 99-02-00028): Attaching this fan to the Clarius Scanner allows for longer scanning time.
- Viera™ Rechargeable Li-Ion battery (CIDN 81-02-00023)
- Viera™ Battery Charger and AC adapter (CIDN 81-02-00024)

Clarius Dock

The Clarius Dock is a separate accessory that you can purchase for your Viera™ Portable Breast Ultrasound. This docking station combines a cooling station that can hold three probes; a battery charger that can charge up to five batteries; and a USB charger that can charge two smart devices, smart phones and/or tablets.

An external power supply is used to connect the Clarius Dock to the AC wall outlet using the supplied power cord.

The Clarius Dock is designed for use in professional healthcare facilities. The device is not intended to contact the patient during normal use. It is not to be used in emergency medical services environments including during patient transport or the home healthcare environment. The Clarius Dock may be used on a counter, desk, or table top. It is not to be placed within 1.5m of the examination table or patient bed.

The Clarius Dock is designed to be used with the Viera™ Portable Breast Ultrasound (CIDN 81-02-00011)

Parts

The Clarius Dock is made up of the following parts:

- A fully-assembled docking station (CIDN 99-02-00025).

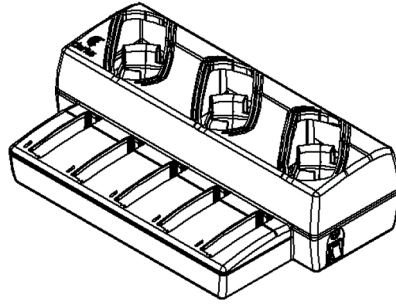

Figure 1: Clarius Dock

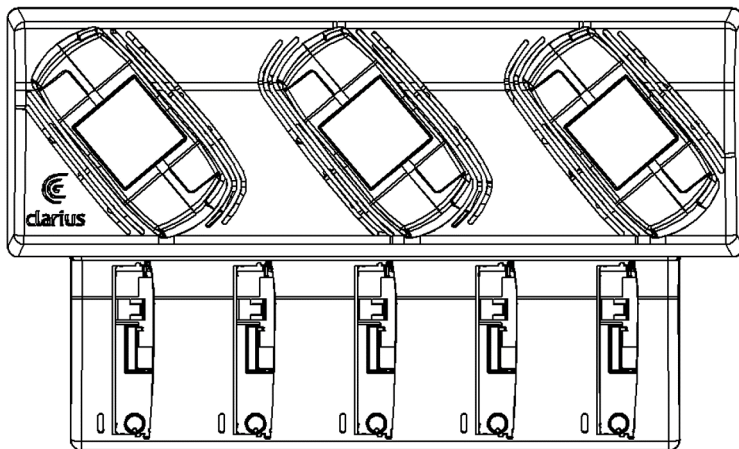

Figure 2: Top View

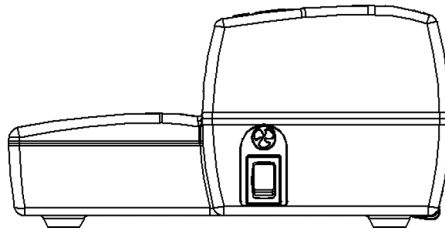

Figure 3: Right Side View

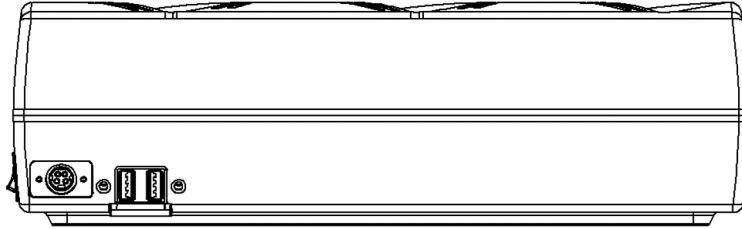

Figure 4: Back View

Before you begin using your Clarius Dock, clean and disinfect it. For cleaning and disinfecting instructions, see *Cleaning & Disinfecting* on page 83.

Technical Specifications

Input	12 VDC, 11.5 A
Output	8.4 VDC, 1.5 A x 5 (charger), 5.0 VDC, 2.3 A x 2 (USB)
Protection Against Electric Shock	Class II
Applied Part	None
Ingress Protection	IP00
Mode of Operation	Continuous

System Specifications

	Operating Limits	Transportation & Storage Limits
Pressure	620 hPa to 1060 hPa (3,954 m to -38 m)	n/a
Humidity	15% to 95% _s	0% to 95%
Temperature	10°C (50°F) to 40°C (113°F)	-20°C (-4°F) to 50°C (122°F)

Setting up

▼To use the Clarius Dock:

1. Clean and disinfect the scanners before placing them in the Clarius Dock.

For cleaning and disinfecting instructions, see *Cleaning & Disinfecting* on page 83.

2. Insert the DC power connector into the Clarius Dock.
3. Connect the AC power cord to the power supply.
4. Insert the AC Male Plug into a power source.

The Clarius Dock is now ready to use.



- Do not place the Clarius Dock within 1.5m of the examination table/patient bed.
- Do not touch the patient and the Clarius Dock at the same time.
- If the AC power cord is damaged, contact Hologic for a replacement.

Using the Clarius Dock

Using the Scanner Coolers

▼To cool the Viera™ Portable Breast Ultrasound:

Move the fan-enable switch to the ON position; indicator on the switch will be green.

Place your scanner directly in the cooling slot.

You can remove the batteries or leave them in the scanner. The fan will activate automatically. It takes approximately five minutes to cool a scanner to operable temperature range.



The cooling fans continue to run while the scanners remain in the cooling slot. When the scanners have cooled, turn off the fan with the enable switch. This will maximize the cooling station's lifespan.



For the fans to operate, the fan-enable switch must be in the ON position.

Using the Battery Charger

▼To charge the scanner battery:

1. Remove the battery from the scanner.
2. Insert the battery into one of the battery slots. There will be a click when the battery is fully inserted.

If you are having problems inserting the battery, start by placing the battery in the charging slot, press down on the battery edge closest to the front of the Clarius Dock then roll the battery towards the back until you hear the click.

It takes approximately 1 ½ hours for an empty battery to fully charge.

Each charger displays the following status lights:

- Orange: Battery is currently charging.
- Green: Battery is fully charged.
- Off: No battery installed, battery not inserted fully, no power connected, or a problem with the battery.



Do not touch battery charger contacts. Only charge Viera™ Rechargeable Li-ion battery packs (CIDN 81-02-00023).

Using the Smart-Device Charger

The Clarius Dock can charge any smart device that is used with the Viera™ Portable Breast Ultrasound.

▼To charge your smart devices:

1. Connect the smart device's charging cable to the smart device as described in the smart device's user manual.
2. Connect the opposite end of the charging cable to one of the two USB Type-A ports on the back of the Clarius Dock. Charge status will be indicated on the smart device.



Do not touch the patient while touching the USB ports. Do not touch the patient with any device connected to the USB ports.

Maintenance

The only maintenance required by the Clarius Dock is to clean and disinfect it. For cleaning instructions, see *Cleaning the Viera™ Portable Breast Ultrasound* on page 84. For disinfecting instructions, see *Disinfecting the Viera™ Portable Breast Ultrasound* on page 85.

If your Clarius Dock requires servicing, please contact Hologic Technical Support.

Troubleshooting

▼The power does not turn on:

The DC power connector may not be fully plugged into the Clarius Dock. Slide the rectangular portion of the DC power connector away from the metallic barrel and re-insert it into the DC jack on the Clarius Dock.

- The DC power connector fits only one way. Ensure that the rectangular side (with the arrows) is facing up.
- The DC power connector fits tight, so you may need to gently wiggle it into the Clarius Dock until you hear a faint click.

Clarius Fan

The Clarius Fan attaches to the built-in heatsink of any Viera™ Portable Breast Ultrasound. Use the Clarius Fan to extend scanning time.

▼To use the Clarius Fan:

1. Align the prongs of the fan with the outlet on the heatsink of the Viera™ Portable Breast Ultrasound.
2. Insert the prongs into the outlet and press until it snaps into place.

Make sure that the prongs are plugged in all the way.

When the Viera™ Portable Breast Ultrasound reaches a temperature of 35°C (95°F), the fan automatically activates.

Clean and disinfect the Clarius Fan after each use. For cleaning instructions, see *Cleaning the Clarius Fan* on page 85. For disinfecting instructions, see *Disinfecting the Clarius Fan* on page 87.

Cleaning & Disinfecting

5

It is important to clean and disinfect the Viera™ Portable Breast Ultrasound immediately after use. This chapter will guide you through the cleaning and disinfecting process.

The classification of cleaning and disinfecting you select will depend on the type of tissue the Viera™ comes into contact with. To find the correct classification, refer to *Spaulding Classification* on page 88.

When cleaning and disinfecting:

- Follow the procedures in the order they are described in this guide, without skipping steps.
- Use only solutions approved by Clarius Mobile Health. Other solutions may be incompatible with the system and could damage the scanner.
- Follow the manufacturer's instructions, recommendations, and guidelines for cleaners and disinfectants, as well as your regional regulations.
- Check expiry dates, concentration, and efficacy of the chemicals used.
- Wear the appropriate personal protective equipment (PPE), such as eyewear and gloves, as recommended by the chemical manufacturer.



- Due to repeated use and cleaning, the cleanliness and sterility of the hardware deteriorates over its service life (five years for the scanner, fan, and Clarius Dock).
- Using incompatible solutions to clean the scanner may damage its surface.
- The scanner and its parts (including accessories) may not withstand the cleaning or disinfecting processes (including repetitive process) specified in this manual, and may damage or deteriorate its safety provisions.

- Cleaning or disinfecting the scanner while the battery is installed may cause the battery to short-circuit and overheat, causing an electric shock or burn.
- Cleaning or disinfecting the scanner using IPA (isopropyl alcohol) may damage it.

During an emergency where the scanner is used to examine multiple patients in a short period of time, the lack of proper cleaning and disinfecting between patients may spread infections to other patients and users.

Cleaning

Cleaning the Viera™ Portable Breast Ultrasound

Before cleaning, visually inspect the scanner to determine that it is free of any unacceptable deterioration, such as corrosion, discoloration, pitting, or cracked seals. If damage is evident, discontinue use and contact Hologic Technical Support.

Cleaning the scanner requires that you select the proper cleaning level. Before you begin, determine the level of cleaning by referring to *Spaulding Classification* on page 88. Once you have determined the level, have the cleaning solution ready and follow the procedure below.

▼To clean the Viera™ Portable Breast Ultrasound:

1. Make sure the Viera™ Portable Breast Ultrasound is turned off.
2. Remove the battery from the scanner.



It is important that you clean the two pieces separately.

3. To clean the scanner, dampen a soft cloth using a compatible cleaner. Alternatively, use a premoistened disinfectant wipe.

For a list of compatible cleaners, see *Cleaners & Disinfectants* on page 126.

4. Start at the top of the scanner and wipe toward the scan head. Be sure to remove any gels or particulate matter.
5. Clean the heat sink (the grooves along the body of the scanner) using a thin, disposable instrument, such as a swab, to push a soft cloth lightly dampened with a cleaning solution (or use a premoistened wipe) across the slot. Move the cloth back and forth from one side of the heat sink to the other.
6. Dispose the cloth and the instrument used to insert the cloth.
7. Verify that all gel, particulate matter, and bodily fluids have been removed.

8. Repeat with new cleaning material if necessary.
9. To clean the battery, dampen another soft cloth using a compatible cleaner or disinfectant. Alternatively, use a premoistened disinfectant wipe.
10. Remove all gel, particulate matter, and bodily fluids from the battery.
11. Repeat with new cleaning material if necessary.

When you are done, keep the two parts separate. You will be disinfecting them individually. For disinfecting instructions, see *Disinfecting the Viera™ Portable Breast Ultrasound* on page 85.



Due to particulate matter (for example, biological agents, ultrasound gel, and dirt) in the scanner crevasses, openings, and/or cavities, there is the possibility that the scanner is not cleaned easily or correctly.

Cleaning the Clarius Fan

▼To clean the Clarius Fan:

1. Remove the Clarius Fan from the Viera™ Portable Breast Ultrasound.
2. Wipe down all surfaces using a premoistened disinfectant wipe.

For a list of compatible cleaners, see *Cleaners & Disinfectants* on page 126.

3. Repeat with new cleaning material if necessary.
4. Air-dry the Clarius Fan.

Alternatively, towel-dry with a clean, non-linting cloth.

When you are done, keep the two parts separate. You will be disinfecting them individually.

Disinfecting

Disinfecting the Viera™ Portable Breast Ultrasound

Before you begin disinfecting, make sure you have cleaned the scanner (see *Cleaning* on page 84).

Disinfecting requires that you choose the proper disinfecting level. Determine the necessary disinfection level by referring to *Spaulding Classification* on page 88. Once you have determined the required disinfecting level, have the disinfectant ready and follow one of the

appropriate procedures below. Note that different levels of disinfection require different steps, not just different solutions.



Scanner is not designed for sterilization. It cannot be sterilized before or between use.

Intermediate Disinfection

Refer to *Cleaners & Disinfectants* on page 126 for a list of disinfectants recommended for intermediate disinfection of the scanner.

If the scanner has come into contact with broken skin, mucosal membranes, or blood, it is classified as semi-critical, and you must perform a high-level disinfection. See *High-Level Disinfection* on page 86 for steps.

1. Make sure the battery is still detached from the scanner.



It is important that you disinfect the two pieces individually.

2. Disinfect the scanner by wiping with a cloth moistened with a compatible disinfectant. Alternatively, use a premoistened disinfectant wipe.
3. Disinfect the heat sink (the grooves along the body of the scanner) using a thin, disposable instrument, such as a swab, to push a soft cloth lightly dampened with a disinfectant (or use a premoistened wipe) across the slot. Move the cloth back and forth from one side of the slot to the other.
4. Remove the disinfecting wipe from the slot.
5. Air-dry. Alternatively, towel-dry with a clean, non-linting cloth.
6. Examine the scanner for damage, such as cracks or splitting where fluid can enter. If damage is evident, do not use the scanner and contact Hologic Technical Support.
7. Disinfect the battery and the battery connector by wiping with a cloth moistened with a compatible disinfectant. Alternatively, use a premoistened disinfectant wipe.



The battery connector is delicate. Handle gently.

8. Air-dry. Alternatively, towel-dry with a clean, non-linting cloth.
9. Examine the battery for damage, such as cracks or splitting where fluid can enter. If damage is evident, do not use the scanner and contact Hologic Technical Support.

High-Level Disinfection

Refer to *Cleaners & Disinfectants* on page 126 for a list of disinfectants recommended for high-level disinfection of the scanner.

1. Make sure the battery is still detached from the scanner.



It is important that you disinfect the two pieces individually.

2. Mix the disinfectant solution by following the disinfectant label instructions for solution strength and disinfectant contact duration.
3. Using the disinfectant CIDEX® OPA, at a temperature of 23°C (73°F), immerse the scanner and the battery in the disinfectant solution for 45 minutes.



If the battery has been recently used or charged, wait 30 seconds before submersing it in any liquid.



It is important that you immerse the two pieces individually, detached from each other.

4. Using the instructions on the disinfectant label, rinse both the scanner and the battery.
5. Air-dry both pieces. Alternatively, towel-dry with a clean, non-linting cloth.
6. Examine the parts for damage, such as cracks or splitting where fluid can enter. If damage is evident, discontinue use of the scanner and contact Hologic Technical Support.

Disinfecting the Clarius Fan

Before you begin disinfecting, make sure you have cleaned the Clarius Fan (see *Cleaning the Clarius Fan* on page 85).

Because the Clarius Fan cannot be submerged in liquid, you must always use intermediate-level disinfection. Refer to *Cleaners & Disinfectants* on page 126 for a list of disinfectants recommended for intermediate disinfection of the Clarius Fan.

1. Make sure that the Clarius Fan is detached from the scanner.



It is important that you disinfect the two pieces individually.

2. Disinfect the Clarius Fan by wiping with a cloth moistened with a compatible disinfectant. Alternatively, use a premoistened disinfectant wipe.

3. Air-dry. Alternatively, towel-dry with a clean, non-linting cloth.
4. Examine the Clarius Fan for damage, such as cracks or splitting. If damage is evident, do not use the fan and contact Hologic Technical Support.

Spaulding Classification

The level of cleaning and disinfecting required for your Viera™ Portable Breast Ultrasound is based on the Spaulding classification system. Following the correct classification will help reduce cross-contamination and infection.

Each Spaulding classification mandates a specific level of cleaning and disinfecting of the equipment before it can be used in the next exam. Determine the Spaulding classification based on your scanner's usage.

SPAULDING CLASSIFICATION

Class	Use	Method
Non-Critical Class	Touches intact skin	Cleaning followed by intermediate disinfection
Semi-Critical Class	Touches mucous membranes and non-intact skin	Cleaning followed by high-level disinfection (HLD)

Safety

6

This chapter provides instructions on the product's safe usage and offers information on safety guidelines. Pay special attention to warnings and cautions, and follow them before, during, and after operating the product:

- Warnings indicate information vital to the safety of you, the operator, and the patient.
- Cautions highlight possible damages to the product that may void your warranty or service contract, or lose patient or system data.

About Diagnostic Ultrasounds

Interactions with Matter

When using diagnostic ultrasound, the sound waves are directed towards an area of interest, which then interacts with any matter along its path. This interaction is determined by the characteristics of the ultrasound wave, as well as the physical properties of the matter through which the sound wave passes. Diagnostic ultrasound frequencies range from 2 MHz to 15 MHz.

History

Ultrasonic energy was first applied to the human body for medical purposes by Dr. George Ludwig at the Naval Medical Research Institute, Bethesda, Maryland in the late 1940s. English-born physicist John Wild (1914–2009) first used ultrasound to assess the thickness of bowel tissue as early as 1949; he has been described as the “father of medical ultrasound”. Subsequent advances in the field took place concurrently in several countries.

Studies

Exposure-effect studies have been performed at intensity levels much higher than those in diagnostic ultrasound practice, which revealed two mechanisms known to alter biological systems:

- Thermal mechanism: Heating of soft tissue and bone.
- Non-thermal mechanism: Mechanical phenomena, such as cavitation.

These mechanisms are discussed later.

Benefits & Risks

Ultrasound is widely used because it provides many clinical benefits to the patient and has an outstanding safety record. In more than three decades of use, there has been no known long-term negative side-effects associated to this technology.

More questions of safety are being discussed because more applications are being discovered, and the industry is producing technically sophisticated scanners that provide more diagnostic information. Dialogue among the medical community, manufacturers, and the FDA has resulted in a standard that allows higher outputs for greater diagnostic capability.

Ultrasound benefits:

- Multiple diagnostic uses
- Immediate results with high-quality information
- Replacement or complimentary or used with other procedures
- Cost-effectiveness
- Portability
- Patient acceptance
- Safety record

Ultrasound risks:

The potential for adverse bioeffects caused by heating or cavitation.

“... the benefits to patients of the prudent use of diagnostic ultrasound outweigh the risks, if any, that may be present.”-- AIUM

Safety Topics

Use the Viera™ Portable Breast Ultrasound only if you have read and understood all the information in this section. Operating the system without proper safety awareness could lead to fatal or serious personal injury.

This section covers general safety information. Safety information applicable to specific tasks are noted in the procedure. The Viera™ Portable Breast Ultrasound is intended for use by a trained medical professional, or by the direction and supervision of a licensed physician qualified to instruct its usage.

“Diagnostic ultrasound is recognized as a safe, effective, and highly flexible imaging modality capable of providing clinically relevant information about most parts of the body in a rapid and cost-effective fashion.” -- WHO (World Health Organization)

Product Safety

Hologic is responsible for the safety of the scanners. The safety of your smart device is your responsibility. Always follow the safety guidelines provided with your smart device before, during, and after use.

Product Warnings



The following actions may cause fatal or other serious injury:

- Using the system without adequate training on its safe and effective operation. If you are unsure of your ability to operate the system safely and effectively, do not use it.
- Attempting to remove, modify, override, or frustrate any safety provisions on the system.
- Using the system with any product that Clarius does not recognize as compatible with the system, or operate the product for unintended purposes.



- If the system appears to be malfunctioning, stop use immediately. Please contact Hologic Technical Support.
- To avoid exposing you and the patient to safety hazards, if any part of the system is known or suspected to be defective or incorrectly adjusted, do not use the system until it is repaired.
- To avoid compromising the effectiveness of the system and the safety of the patient, the user, and others, do not operate the system with patients unless you have an adequate understanding of its capabilities and functions.
- Configure your smart device in compliance with your institution's security policies. For example, notifications and alerts from third-party applications may interfere with an exam.

Product Compatibility

The Viera™ Portable Breast Ultrasound comes with a battery, a battery charger, and a power supply for the charger. Do not use your system in combination with other products or components not made by Clarius, unless Clarius expressly recognizes those other products or components as compatible.

Changes and additions to the system can be made only by Clarius or by third parties expressly authorized by Clarius to do so. Such changes and additions must comply with all applicable laws and regulations that have the force of law within the jurisdictions concerned, and best engineering practices. System changes and additions that are made without the appropriate training or by using unapproved spare parts may carry risks of system damage and personal injury.

Battery Safety



If the battery fails to charge fully, replace it.

- Keep the battery away from heat sources. For example, do not charge the battery near a fire or heater.
- Do not discard the battery in fire.
- Do not open, crush, puncture, or short-circuit contacts.
- If the battery leaks or emits an odor, remove it from the scanner and contact Hologic Technical Support.
- If the battery emits an odor or heat, is deformed or discolored, or in any way appears abnormal during use, recharging or storage, immediately remove it and stop using it. If you have any questions about the battery, please contact Hologic Technical Support.
- If the battery is to remain unused for over a month, keep the charge level between 40% and 50% to prolong its life, and store it in temperatures between -20°C (-4°F) and 20°C (68°F).



The following actions may damage the battery:

- Returning a battery without instructions from Hologic Technical Support.
- Short-circuiting the battery by connecting the positive and negative terminals directly to metal objects.
- Using the battery in temperatures below -20°C (-4°F) or above 60°C (140°F).
- Charging the battery in temperatures below 10°C (50°F) or above 45°C (113°F).
- Forcing the battery into the system. The polarity of the battery terminals is fixed and cannot be reversed.
- Connecting the battery to an electrical power outlet.
- Charging the battery using non-Clarius equipment. Always charge the battery using the

battery charger provided by Clarius.

- Do not touch battery contacts.
- Do not leave the battery in direct sunlight.

Cleaning Safety

It is important to clean and maintain the ultrasound system and peripherals. Thorough cleaning is particularly important for pieces of peripheral equipment, because they contain electromechanical parts. If exposed to constant and excessive sunlight and humidity, the scanner will suffer in both performance and reliability.

It is your responsibility to clean and disinfect your scanner in accordance with the cleaning and disinfecting instructions in this manual. For instructions on cleaning and disinfecting the Viera™ Portable Breast Ultrasound, refer to *Cleaning* on page 84.

Cleaners & Disinfectants



- Use only cleaners and disinfectants recommended by Clarius. Avoid acetone, Methyl ethyl ketone (MEK), paint thinner, or other strong solvents and abrasive cleaners.
- Always use protective eyewear and gloves when cleaning and disinfecting equipment.
- Disinfectants are recommended based on their chemical compatibility (not their biological effectiveness) with product materials. For the biological effectiveness of a disinfectant, see the guidelines and recommendations of the disinfectant manufacturer, the U.S. Food and Drug Administration, and the U.S. Centers for Disease Control.
- If a pre-mixed solution is used, check the expiry date.
- The level of disinfection required for a scanner is determined by the type of tissue it contacts. Ensure the disinfectant is appropriate for the scanner and its application. Also, read the disinfectant label instructions and the recommendations of the Association for Professionals in Infection Control, the U.S. Food and Drug Administration, and the U.S. Centers for Disease Control.
- Clean the scanner after each use. This is an essential step before disinfection.
- When disinfecting a scanner, ensure that the solution's strength and duration of contact are appropriate for disinfection.
- Selecting a non-recommended solution, using an incorrect solution strength, or immersing a scanner deeper or longer than recommended can damage the scanner.
- Follow the manufacturer's recommendations and instructions when using cleaners and disinfectants.

Minimizing the Effects of Residual Disinfectant

If you use an OPA-based disinfectant, residual solution may remain on your scanners if you do not carefully follow the manufacturer's instructions.

To minimize the effects from residual OPA, or any other disinfectant, Clarius recommends the following:

- Follow the disinfectant manufacturer's instructions very carefully.
- Limit the time that scanners are soaked in the disinfectant solution to the minimum time recommended by the disinfectant manufacturer.

Factors Affecting Disinfectant Efficacy

The following factors will affect the efficacy of a disinfectant solution:

- Number and location of microorganisms
- Innate resistance of microorganisms
- Concentration and potency of disinfectants
- Physical and chemical factors
- Organic and inorganic matter
- Duration of exposure
- Biofilms

Scanner Care

Lint, dust, and light (including sunlight) have no effect on the scanner's basic safety and essential performance.



- Avoid sharp objects, such as scissors, scalpels, or cauterizing knives, from touching the scanners.
- Avoid bumping the scanner on hard surfaces.
- Avoid surgeon's brushes when cleaning scanners. Even soft brushes can damage scanners.
- Before storing scanners, make sure they are completely dry. If it is necessary to dry the scanner lens or acoustic window, apply a soft cloth to the area, and blot rather than wipe.
- Use only liquid solutions to disinfect scanners.
- Regularly check the lens of the scanner's acoustic window for degradation, as described in *Cleaning* on page 84, to prevent degradation of image quality and abrasions to the patient's skin.



The following actions may damage your scanner:

- Cleaning or disinfecting a scanner using methods unapproved by Clarius.
- Using paper or abrasive products. They damage the soft lens of the scanner's acoustic window. If the lens is damaged to the point that the scanner elements are exposed, stop using the scanner and please contact Hologic Technical Support immediately. Exposed scanner elements may cause burns or electric shock to the patient.

- Soaking the scanner for extended periods. Use soaking time and depth recommended by the disinfectant manufacturer.

Clinical Safety

Syringe Safety



- If the needle is not visible, do not perform the needle procedure.
- Thin needles can bend when entering tissue. Verify the needle's position by identifying the echoes from the needle.
- Make sure you are not using a false needle image to locate the needle. False needle images caused by reverberation or other tissue artifacts can misguide you.

Defibrillator Safety

If you are using the Viera™ Portable Breast Ultrasound and defibrillation is required, use defibrillators that do not have grounded patient circuits. To determine whether a defibrillator patient circuit is grounded, see the defibrillator service guide, or consult a biomedical engineer.

Before defibrillation, remove any part of the system that is in contact with the patient.

Biological Safety



- Do not use a system that exhibits erratic or inconsistent image updates. This indicates a hardware failure that must be corrected before continuing use.
- Follow the ALARA (as low as reasonably achievable) principle.

Latex

Viera™ Portable Breast Ultrasounds do not contain natural rubber latex.

The following are FDA recommendations on latex awareness:

- When taking general histories of patients, include questions about latex sensitivity. For surgical and radiology patients, spina bifida patients and health care workers, this recommendation is especially important. Questions about itching, rashes, or wheezing after wearing latex gloves or inflating a toy balloon may be useful. For patients with positive histories, flag their charts.
- If latex sensitivity is suspected, consider wearing a non-latex glove over the latex glove if the patient is sensitive. If both the health professional and the patient are sensitive, a latex middle glove could be used. (Latex gloves labeled “Hypoallergenic” may not always prevent adverse reactions.)

- Whenever latex comes in contact with mucous membranes, be alert to the possibility of an allergic reaction.
- If an allergic reaction does occur and latex is suspected, advise the patient of a possible latex sensitivity and consider an immunologic evaluation.
- Advise the patient to tell health professionals and emergency personnel about any known latex sensitivity before undergoing medical procedures. Consider advising patients with severe latex sensitivity to wear a medical identification bracelet.

Bioeffects

Thermal

Thermal bioeffects refers to heat generated whenever ultrasound energy is absorbed, and amount of heat produced depends on the ultrasound's intensity, exposure time, and the tissue's absorption characteristics.

Tissue absorbs ultrasound energy to varying degrees depending on the tissue's absorption characteristics. Absorption characteristics are quantified by the absorption coefficient:

- Fluids: Their absorption coefficient is almost zero. Fluids such as amniotic fluid, blood, and urine absorb very little ultrasonic energy. That means the ultrasound goes through the fluid with very little decrease. And there's little temperature elevation in the fluid.
- Bone: Its absorption coefficient is very high. Dense bone absorbs the energy very quickly and causes the temperature to rise rapidly. Adult bone absorbs nearly all acoustic energy impinging on it. Fetal bone absorption coefficients vary greatly depending on the degree of ossification.
- Soft tissue: Soft tissue varies in density depending on the organ, but the density does not vary much within an organ. We call it soft tissue to distinguish it from hard tissue such as bone. Also, the tissue density within a particular organ is not always the same. But for our purposes, we assume that attenuation is uniform throughout the organ. We call this a homogeneous soft tissue model.

Attenuation is caused by:

- Absorption: Energy converted to heat.
- Scattering: Redirection of ultrasound.

Mechanical (Non-Thermal)

Mechanical bioeffects are threshold phenomena, such as cavitation, that occur when the output exceeds a certain level. This threshold varies by tissue type.

Cavitation is the interaction of ultrasound with gas bubbles, causing rapid and potentially large changes in bubble size. These bubbles originate within materials at locations termed nucleation sites, the exact nature and source of which are not well understood in a complex

medium such as tissue or blood. The change in bubble size may increase temperature and pressure within the bubble, causing mechanical stress on surrounding tissues, precipitate fluid microjet formation, and generate free radicals. Gas-containing structures, such as lungs, are most susceptible to the effects of acoustic cavitation; however, such higher frequency ultrasounds do not provide sufficient time for significant bubble growth; therefore, cavitation is unlikely to occur under these circumstances. Factors that produce cavitation include: pressure (compressional, rarefactional), frequency, focused/unfocused beam, pulsed/continuous waves, degree of standing waves, boundaries, and the nature and state of material.

Scientific evidence suggests that the onset of transient cavitation is a threshold phenomenon. There's a combination of rarefactional pressure values, ultrasonic frequency, and cavitation nuclei that are required for inertial cavitation to occur. If inertial cavitation is a threshold phenomenon, then exposure to pressure levels below the threshold will never induce such events, regardless of the length of exposure.

There are two categories of cavitation:

- **Stable:** Stable cavitation is associated with vibrating gas bodies. In stable cavitation, a gas body oscillates or pulsates continuously around its equilibrium size. As the oscillations become established, the liquid-like medium around the gas body begins to flow or stream; we call this microstreaming. Microstreaming has been shown to produce stress sufficient to disrupt cell membranes.
- **Inertial:** During inertial (transient) cavitation, pre-existing bubbles or cavitation nuclei expand because of the rarefactional pressure of the ultrasonic field and then collapse in a violent implosion. The whole process takes place in a time span on the order of microseconds. The implosion can produce huge local temperature rises that may be thousands of degrees Celsius and pressures equal to hundreds of atmospheres, all in a volume of less than 1 μm^3 . The implosion can damage cells and tissue, ultimately leading to cell death. In addition, bubble implosion can generate highly reactive chemical species. All of these effects, microstreaming, implosion, and generation of reactive chemicals, occur in a very small space around the bubble, affecting only a few cells.

Exposure of the lung can produce small, localized hemorrhages under some conditions in laboratory animals. These lesions resolve naturally and are without lasting effects in normal subjects, but their possible significance in compromised individuals has not been studied.

ALARA Principle

The guiding principle for the use of diagnostic ultrasound is defined by the ALARA (as low as reasonably achievable) principle. The threshold for diagnostic ultrasound bioeffects is undetermined, and the definition of “reasonable” is left to the judgment and insight of qualified personnel. No set of rules can be formulated that would be sufficiently complete to dictate the correct response to every circumstance. By keeping ultrasound exposure as low as reasonably achievable as you obtain diagnostic images, you can minimize ultrasonic bioeffects.

Output display indices are designed to provide more quality information, to help guide the sonographers using ultrasound technology, in applying the ALARA principle. Some variables that affect the way output display indices can be used to implement the ALARA principle:

- index values
- body size
- location of the bone relative to the focal point
- attenuation in the body
- ultrasound exposure time (an especially useful variable, as it is controlled by the user)

Applying ALARA

The system's imaging mode you select depends on the information needed. Understanding the nature of the imaging mode used, the scanner frequency, system setup values, scanning techniques, exposure time, system and scanner capabilities, and operator experience allows the sonographer to apply the ALARA principle with informed judgment and meet the definition of the ALARA principle.

The amount of acoustic output is up to the system operator. This decision must be based on the following factors: type of patient, type of exam, patient history, ease or difficulty of obtaining diagnostically useful information, and the potential localized heating of the patient due to scanner surface temperatures. The objective is to limit patient exposure to the lowest index reading for the shortest amount of time achieving acceptable diagnostic results.

A high index reading does not necessarily indicate the occurrence of a bioeffect, however, it must be taken seriously. It is your responsibility to make every effort to reduce the possible effects of a high index reading by limiting exposure time.

System controls (direct, indirect, and receiver) can be used to adjust the image quality and limit the acoustic intensity, and are related to the techniques that an operator could use to implement ALARA.

Using System Controls to Implement ALARA

Direct Controls

The system has no direct control for output, therefore the sonographer must control exposure time and scanning technique to implement the ALARA principle. To ensure that acoustic and thermal limits are not exceeded for all imaging modes, the Viera™ Portable Breast Ultrasound is designed to automatically adjust output.

The system does not exceed a spatial peak temporal average intensity (I_{SPTA}) of 720 mW/cm^2 for all imaging modes. The mechanical index (MI) and thermal index (TI) may exceed values greater than 1.0 on some scanners in some imaging modes.

Indirect Controls

Controls affecting imaging mode, freeze, and depth indirectly affect output. The imaging mode determines the nature of the ultrasound beam. Because freeze stops all ultrasound output but keeps the last image displayed on screen, you can use it to limit exposure time while studying an image and maintaining scanner position during a scan. Some controls, such as depth, show a rough correspondence with output, and may be used as a general means for indirectly reducing MI or TI.

Controls indirectly affecting intensity:

- Pulse repetition frequency: The higher the PRF, the more output pulses per second, increasing the temporal-average intensity.
- Focusing depth: Setting the scanner focus at the proper depth improves the resolution of that structure, without the need to increase intensity to see it better.
- Pulse length: Generally, the longer the pulse, the greater the temporal-average intensity value, which both raises the temperature in the tissue and slightly increases the likelihood for cavitation.
- Dwell time: Scanned modes, such as B-Mode imaging, distribute the energy over a large volume. In scanned modes (equipment keeps the beam stationary), the highest temperature is frequently at the surface where the ultrasound enters the body.

Receiver Controls

The receiver controls have no output effect. The following receiver controls affect images only:

- Gain or time-gain control (TGC)
- Dynamic range
- Post-processing

User Responsibility

The various operating modes and output levels mean that more responsibility must be assumed by the users. This is a point that is very often neglected: many assume that if an instrument is “FDA cleared,” then there is no risk of bioeffects. This notion is inaccurate because changing the mode of operation or manipulating controls has the potential to cause major changes in output and hence in exposure. In other words, there is a shift in responsibility for patient safety from the manufacturer to the user.

To obtain good diagnostic information, a high return signal amplitude is needed. This can be attained either by higher output, similar to talking louder, or by higher receiver gain, similar to a hearing aid with a volume control. You must attain the best diagnostic information with minimal exposure to the patient. The threshold at which ultrasound energy causes bioeffects for each individual patient is unknown, therefore, you must get the most information at the lowest possible output level by adjusting the output intensity of the equipment.

As a general guideline:

1. Select the correct scanner frequency and application.
2. Start with a low output level.
3. Optimize the image by using focus, receiver gain, and other imaging controls.
4. If the image is still not diagnostically useful, increase output.

Additional considerations:

- Minimize scan time by performing only medically required ones.
- Use diagnostic ultrasounds efficiently and effectively, as all other medical tools.
- Compromising the exam's quality by rushing the exam could result in a poor exam, which could require follow-up exams, which then adds exposure time.
- Select the appropriate TI and MI range for the task at hand.
- Note that output is affected by frequency, focus, pulse length, and dwell time.

Output Display

The output display provides the user with an indication of the potential for bioeffects that might be caused by the ultrasound energy being emitted. With this information, users can better control the diagnostic ultrasound equipment and examination to ensure that needed diagnostic information is obtained with a minimum of risk to the patient.

Display Standards

The system output display consists of the following exposure indices to indicate the potential thermal and mechanical effects:

- TI: This is continuously displayed over the range of 0.0 to maximum output, based on the scanner and application, in increments of 0.1, and consists of the following indices:
 - thermal index for soft tissue (TIS)
 - thermal index for bone (TIB)
 - thermal index for cranial bone (TIC)

Keep output display indices to a minimum. Select a TI based on:

- Approximate index for the application: TIS is used for imaging soft tissue, TIB for a focus at or near bone, and TIC for imaging through bone near the surface (for example, a cranial exam).
- Mitigating factors that might create artificially high or low TI readings: Location of fluid or bone, or blood flow. For example, is there a highly attenuating tissue path so that the actual potential for local zone heating is less than the TI displays?
- Scanned modes versus unscanned modes of operation that affect the TI: For scanned modes (such as B-Mode), heating tends to be near the surface. For

unscanned modes (such as M-Mode or Doppler-type modes), the potential for heating tends to be deeper in the focal zone.

- MI: This is continuously displayed over the range of 0.0 to 1.9, in increments of 0.1.

TI Display

The TI indicates any conditions that may lead to temperature increase on the surface of the body, within the body tissue, or at the point of focus of the ultrasound beam on bone. TI informs you of a potential rise in temperature of body tissue, by estimating temperature increases in those body tissue with specific properties. The actual temperature increase is influenced by factors such as tissue type, vascularity, and mode of operation. Use the TI as a guide for implementing the ALARA principle.

You can choose to display one of the following types of TI indices:

- TIS: Indicates potential for heating within soft homogeneous tissue.
- TIB: Indicates potential for heating at or near the focus after the ultrasound beam has passed through soft tissue or fluid. For example, at or near second- or third-trimester fetal bone.
- TIC: Indicates potential for heating of bone at or near the surface. For example, cranial bone.

MI Display

The higher the MI value, the greater the likelihood of mechanical bioeffects occurring. The potential for mechanical bioeffects varies by peak rarefactional pressure and ultrasound frequency. The MI accounts for these two factors. There is no specific MI value that indicates the occurrence of a mechanical effect. Use the MI as a guide for implementing the ALARA principle.

When interpreting the MI, remember that it is intended to estimate the potential for mechanical bioeffects. The higher the index reading, the greater the potential. However, neither MI = 1 nor any other level indicates that a bioeffect is actually occurring. We should not be alarmed by the reading, but we should use it to implement the ALARA principle.

Display Accuracy

The MI and TI have a precision of 0.1 unit on the system.

Estimates of the MI and TI display accuracies are shown in the Acoustic Output Tables. The following factors are considered when estimating the accuracy of the displayed values:

- hardware variations

Variability among scanners and systems is a result of piezoelectric crystal efficiencies, process-related impedance differences, and sensitive lens-focusing parameter variations.

- estimation algorithm accuracy

Differences in system pulser voltage control and efficiencies are also contributor to variability. There are inherent uncertainties in the algorithms used to estimate acoustic output values over the range of possible system operating conditions and pulser voltages.

- measurement variability

Inaccuracies in laboratory measurements can be caused by hydrophone calibration and performance, positioning, alignment, and digitization tolerances, and variability among test operators.

Controls Affecting Display Indices

Use system controls to change the TI and MI values.

Power Controls

Two real-time output values are on the display: TI and MI. These change as the system responds to power-control adjustments. In combined modes, the individual modes each add to the total TI. One mode will be the dominant contributor to this total. The displayed MI will be from the mode with the largest MI value.

B-Mode Controls

- Focus:

When the focal depth is near the natural focus of the scanner, the MI may be higher.

- Zoom:

Increasing the zoom magnification by spreading the display may increase frame rate, thereby increasing the TI. The number of focal zones may also increase automatically to improve resolution. This action may change the MI, because the peak MI can occur at a different depth.

Other Control Effects

- B-Mode Depth:

An increase in two-dimensional depth will automatically decrease the B-Mode frame rate, thereby decreasing the TI. The system may also automatically choose a deeper two-dimensional focal depth. A change of focal depth may change the MI. The MI displayed is that of the zone with the largest MI value.

- Application:

Acoustic output defaults are set when you select an application. Factory defaults vary with scanner, application, and mode. Defaults have been chosen below the FDA limits for intended use.

- Imaging Mode Controls:

When a new imaging mode is selected, both the TI and MI may change to default settings. Each mode has a corresponding pulse repetition frequency and maximum intensity point. In combined or simultaneous modes, the TI is the sum of the contribution from the modes enabled, and the displayed MI is the largest of the MI values associated with each mode and focal zone enabled. The system will return to the previously selected state if a mode is turned off and then reselected.

- Scanner:

Each scanner type has unique specifications for contact area, beam shape, and center frequency. Selecting a scanner initializes its default settings, which varies by scanner, application, and selected mode. These defaults are set below the FDA limits for intended use.

Example of reducing output:

Imagine we are getting ready to do a liver scan. The first thing we need to do is select the appropriate scanner frequency. Next, we adjust the output intensity (or power) transmit setting. We check to make sure that it is positioned at the lowest possible setting to produce an image. We adjust the focus to the area of interest and then increase the receiver gain to produce a uniform representation of the tissue. If we can obtain a good image by increasing the gain, we can lower the output and continue to increase the gain. Only after making these adjustments and if tissue penetration or echo amplitude levels are inadequate should we increase the output to the next higher level.

Acoustics

The scanner is the most important factor in image quality. Optimal imaging cannot be obtained without the correct scanner. The system is optimized for use based on your scanner selection.

The system limits patient contact temperature to 43°C (109°F), and acoustic output values to their respective U.S. Food and Drug Administration limits. A power-protection circuit protects against over-current conditions. If the power monitor protection circuit senses an over-current condition, then the drive voltage to the scanner is shut off immediately, preventing overheating of the scanner surface and limiting acoustic output. Validation of the power protection circuit is done under normal system operation.

A temperature elevation of less than 1.5°C (2.7°F) is considered harmless to human tissue (including embryo or fetus). Temperatures in excess of this may cause harm, depending on the length of time maintained. A temperature elevation of 4°C (7.2°F), maintained for five minutes or more, is considered to be potentially hazardous to a fetus or embryo.

Acoustic Artifacts

An acoustic artifact is information, present or absent in an image, which does not properly indicate the structure or flow being imaged. Examples of acoustic artifacts that hinder proper interpretation:

- Added objects displayed as speckle, section thickness, reverberation, mirror image, comet tail, or ring down.
- Missing objects due to poor resolution.
- Incorrect object brightness due to shadowing or enhancement.
- Incorrect object location due to refraction, multi-path reflections, side lobes, grating lobes, speed error, or range ambiguity.
- Incorrect object size due to poor resolution, refraction, or speed error.
- Incorrect object shape due to poor resolution, refraction, or speed error.

Acoustic Output & Measurement

The acoustic output for this system has been measured and calculated in accordance with the “Acoustic Output Measurement Standard for Diagnostic Ultrasound Equipment” (Revision 3, AIUM, NEMA, 2004), the “Standard for Real-Time Display of Thermal and Mechanical Acoustic Output Indices on Diagnostic Ultrasound Equipment” (Revision 2, AIUM, NEMA, 2004), and the September 2008 FDA document “Information for Manufacturers Seeking Marketing Clearance of Diagnostic Ultrasound Systems and Scanners.”

In Situ, Derated, & Water Value Intensities

All intensity parameters are measured in water. Because water absorbs very little acoustic energy, these water measurements represent a worst-case value. Biological tissue does absorb acoustic energy. The true value of the intensity at any point depends on the amount and type of tissue and the frequency of the ultrasound that passes through the tissue. The intensity value in the tissue, in situ, has been estimated by using the following formula:

In situ = Water [e-(0.23alf)] Where:

Variable	Value
In Situ	In situ intensity value
Water	Water value intensity
e	2.7183
a	Attenuation factor
Tissue	a(dB/cm-MHz)
Amniotic Fluid	0.006

Brain	0.53
Heart	0.66
Kidney	0.79
Liver	0.43
Muscle	0.55
l	Skin line to measurement depth (cm)
f	Center frequency of the scanner/system/mode combination (MHz)

Because the ultrasonic path during an examination is likely to pass through varying lengths and types of tissue, it is difficult to estimate the true in situ intensity. An attenuation factor of 0.3 is used for general reporting purposes. Therefore, the in situ value which is commonly reported uses the formula:

$$\text{In situ derated} = \text{Water} [e^{-(0.069lf)}]$$

Because this value is not the true in situ intensity, the term “derated” is used.

Mathematical derating of water based measurements using the 0.3 dB/cm MHz coefficient may yield lower acoustic exposure values than would be measured in a homogenous 0.3 dB/cm MHz tissue. This is true because nonlinearly propagating acoustic energy waveforms experience more distortion, saturation, and absorption in water than in tissue, where attenuation present all along the tissue path will dampen the buildup of nonlinear effects.

The maximum derated and the maximum water values do not always occur at the same operating conditions. Therefore, the reported maximum water and derated values may not be related by the in situ (derated) formula. For example: A multi-zone array scanner that has maximum water value intensities in its deepest zone may have its largest derated intensity in one of its shallowest focal zones.

Conclusions Regarding Tissue Models & Equipment Survey

Tissue models are necessary to estimate attenuation and acoustic exposure levels in situ from measurements of acoustic output made in water. Presently, available models may be limited in their accuracy because of varying tissue paths during diagnostic ultrasound exposures and uncertainties in acoustical properties of soft tissues. No single tissue model is adequate for predicting exposures in all situations from measurements made in water, and continued improvement and verification of these models is necessary for making exposure assessments for specific applications.

A homogeneous tissue model with an attenuation coefficient of 0.3 dB/cm MHz throughout the beam path is commonly used when estimating exposure levels. The model is conservative in that it overestimates the in situ acoustic exposure when the path between the scanner and the site of interest is composed entirely of soft tissue, because the attenuation coefficient of

soft tissue is generally higher than 0.3 dB/cm MHz. When the path contains significant amounts of fluid, as in many first- and second-trimester pregnancies scanned transabdominally, this model may underestimate the in situ acoustical exposure. The amount of underestimation depends on each specific situation. For example, when the beam path is longer than 3 cm and the propagation medium is predominantly fluid (conditions that may exist during transabdominal OB scans), a more accurate value for the derating term is 0.1 dB/cm MHz.

Fixed-path tissue models, in which soft tissue thickness is held constant, sometimes are used to estimate in situ acoustical exposures when the beam path is longer than 3 cm and consists largely of fluid. When this model is used to estimate maximum exposure to the fetus during transabdominal scans, a value of 1 dB/cm MHz may be used during all trimesters.

The maximum acoustic output levels of diagnostic ultrasound scanners extend over a broad range of values:

- A survey of 1990-equipment models yielded MI values between 0.1 and 1 at their highest output settings. Maximum MI values of approximately 2 are known to occur for currently available equipment. Maximum MI values are similar for real-time B-Mode, M-mode, and PW Doppler.
- Computed estimates of upper limits to temperature elevations during transabdominal scans were obtained in a survey of 1988 and 1990 Doppler equipment. The vast majority of models yielded upper limits less than 1°C and 4°C (1.8°F and 7.2°F) for exposures of first-trimester fetal tissue and second-trimester fetal bone, respectively. The largest values obtained were approximately 1.5°C (2.7°F) for first-trimester fetal tissue and 7°C (12.6°F) for second-trimester fetal bone. Estimated maximum temperature elevations given here are for a “fixed-path” tissue model and are for scanners having I_{spta} (derated) values greater than 500 mW/cm². The temperature elevations for fetal bone and tissue were computed based on calculation procedures given in Sections 4.3.2.1 through 4.3.2.6 in “Bioeffects and Safety of Diagnostic Ultrasound” (AIUM Report, January 28, 1993).

Acoustic Measurement Precision & Uncertainty

All table entries have been obtained at the same operating conditions that give rise to the maximum index value in the first column of the tables. Measurement precision and uncertainty for power, pressure, intensity, and center frequency are listed in the following tables.



Measurement precision on the following quantities is determined by making repeated measurements and stating the standard deviation as a percentage.

ACOUSTIC MEASUREMENT PRECISION

Quantity	Precision (Percentage Standard Deviation)
Pr is the underated peak rarefactional pressure measured in megapascals (MPa)	Pr: 5.4%

ACOUSTIC MEASUREMENT PRECISION

Wo is the ultrasonic power in milliwatts (mW)	6.2%
f_c is the center frequency in megahertz (MHz) (NEMA UD-2 definition)	<1%
PII.3 is the derated spatial-peak pulse intensity integral in joules per square centimeter (J/cm^2)	PII.3: 3.2%

ACOUSTIC MEASUREMENT UNCERTAINTY

Quantity	Measurement Uncertainty (Percentage, 95% Confidence Value)
Pr is the underated peak rarefactional pressure measured in megapascals (MPa)	Pr: $\pm 11.3\%$
Wo is the ultrasonic power in milliwatts (mW)	$\pm 10\%$

Fire & Electrical Safety**Fire Safety**

Always have fire extinguishers available for both electrical and non-electrical fires.

In the event of an electrical or chemical fire, use only extinguishers that are specifically labeled for such purposes. Using water or other liquids can cause fatal or other serious personal injury. To reduce the risk of electrical shock, try isolating the product, if safe to do so.

Using electrical products in an environment for which they were not designed to be used can lead to fire or explosion. Apply, observe, and enforce appropriate fire regulations for the type of medical area being used.

Electrical Safety

- To reduce electrical shock hazards, inspect the scanner face and housing before use. Discontinue use if the housing is damaged, or if the face is cracked, chipped, or torn.
- All patient-contact scanners not specifically indicated as defibrillation-proof must be removed from the patient before applying high-voltage defibrillation pulse.
- High-frequency electrical signals from an ultrasound can interfere with pacemaker operation. Be alert to this unlikely but potential hazard and stop using the system if you notice it is interfering with a pacemaker.
- Connecting accessories not supplied or approved by Clarius could result in electrical shock.
- Electrosurgical units (ESUs) and other scanners intentionally introduce RF electromagnetic fields (currents) into patients. Because imaging ultrasound frequencies are within the RF

range, ultrasound scanner circuits are susceptible to RF interference.

- A burn hazard may result from a surgical equipment with a defect in the high-frequency surgical neutral electrode connection. Do not use scanners with high-frequency surgical equipment.
- Using accessories other than those specified for use with the Viera™ Portable Breast Ultrasound may result in increased emissions of the system.

Electromagnetic Safety

The Viera™ Portable Breast Ultrasound uses wireless technology to communicate with your smart device. Wireless communication can be affected by severe weather conditions and radio frequency interference. Such environments will not cause the safety of the Viera™ Portable Breast Ultrasound to deteriorate, but the captured image may show signs of unwanted noise and/or artifacts. The technology used in the Viera™ Portable Breast Ultrasound is designed to minimize these affects but may not eliminate them entirely.

Electromagnetic Compatibility

The Viera™ Portable Breast Ultrasound been manufactured with existing electromagnetic compatibility requirements and have been tested and found to comply with electromagnetic compatibility standards to provide reasonable protection against harmful interference in a typical medical installation.



When this status icon is green, it indicates good wireless network connection. If it is yellow, orange, or red, it indicates varying degrees of congestion. This status icon is displayed on the Clarius App's live imaging page.

Use of this system in the presence of an electromagnetic field can cause momentarily degraded image quality. If this occurs frequently, review the environment surrounding the system and identify possible sources of radiated emissions. These emissions could be caused by other electrical equipment from:

- The same or adjacent room.
- Portable or mobile RF communications equipment (such as cellular phones and pagers).
- Radio, TV, or microwave transmission equipment located nearby.

The scanner's built-in radio operates in the 2.4 GHz and 5 GHz bands, and supports:

- Bluetooth 4.1 as well as CSA2.
- IEEE Std 802.11a, 802.11b/g, and IEEE Std 802.11n data rates with 20 MHz or 40 MHz SISO and 20 MHz MIMO.



Caution:

- Using parts and accessories not recommended by Clarius may result in increased emissions or decreased immunity of the system. Use only accessories and peripherals recommended by Clarius.
- EMC precautions for medical equipment must be followed according to the EMC information provided in that system's accompanying documents.
- The Viera™ Portable Breast Ultrasound's AC power supply cable is limited to 1.5 m (4.9 feet).

Electrostatic Discharge Precautions

Electrostatic discharge (ESD), or static shock, results from the flow of an electrical charge from a person or object of a higher charge to that of a lower charge. ESD is most prevalent in low-humidity environments, often caused by heating or air-conditioning.



To reduce ESD:

- Use anti-static spray on carpets, linoleum, and mats. Or use a ground wire connection between the system and the patient table or bed.
- Do not touch the connector pins on the battery.

Electromagnetic Emissions

Ensure that the Viera™ Portable Breast Ultrasound is used only in those operating environments indicated in the following table. Operating the system in an environment that does not meet these conditions may degrade system performance.

DECLARATION OF ELECTROMAGNETIC EMISSIONS

Emissions Test	Compliance	Electromagnetic Environment
RF emissions, CISPR 11	Group 1	The system uses RF energy only for its internal function. Therefore, its RF emissions are very low and are not likely to cause any interference in nearby electronic equipment.
RF emissions, CISPR 11	Class A	The system is suitable for use in all establishments, except domestic establishments and those directly connected to the public low-voltage power supply network that supplies buildings used for domestic purposes
Harmonic emissions, IEC 61000-3-2	Class A	
Voltage fluctuations/flicker emissions, IEC 61000-3-3	Complies	

Electromagnetic Immunity

Immunity Test	IEC 60601-1-2 Test Level	Compliance Level
ESD @ battery mode transmitting and charge mode* EN/IEC 61000-4-2	+/-2kV, +/-4kV, +/-8kV Contact +/-2kV, +/-4kV, +/-8kV, +/-15kV Air	+/-2kV, +/-4kV, +/-8kV contact +/-2kV, +/-4kV, +/-8kV, +/-15kV Air
Radiated, radio frequency electromagnetic field immunity - battery mode transmitting and charge mode (1 kHz 80% AM for ETSI 301 489-1 and -17 @ battery only, 2 Hz modulation for IEC 60601-1-2)* EN/IEC 61000-4-3	3 V/M 2 Hz modulation	3 V/M 2 Hz modulation
Electrical fast transient @ charge mode IEC 61000-4-4	+/-0.5kV, +/-1.0kV	+/-0.5kV, +/-1.0kV
Immunity to surge @ charge mode IEC 61000-4-5	0.5kV, 1.0kV, 2.0kV common mode 0.5kV, 1.0kV differential mode	0.5kV, 1.0kV, 2.0kV common mode 0.5kV, 1.0kV differential mode
Conducted, radio-frequency electromagnetic immunity test @ charge mode (2 Hz modulation) IEC 61000-4-6	3 VRMS-6VRMS in ISM bands 2 Hz modulation	3 VRMS-6VRMS in ISM bands 2 Hz modulation
Power frequency magnetic field immunity test @ battery and charge mode IEC 61000-4-8	30A/M	30A/M
Voltage dips/ interruptions @ charge mode IEC 61000-4-11	0% for 0.5 cycle @ 0°, 45°, 90°, 135°, 180°, 225°, 270°, 315° 0% for 1 cycle @ 0° 70% for 25/30 cycles (50/60 Hz) @ 0° 0% for 250/300 cycles @ 0°	0% for 0.5 cycle @ 0°, 45°, 90°, 135°, 180°, 225°, 270°, 315° 0% for 1 cycle @ 0° 70% for 25/30 cycles (50/60 Hz) @ 0° 0% for 250/300 cycles @ 0°

*For ETSI 301 489-1 and ETSI 301 489-17: Tested in transmit mode only, no idle mode exists for this product.

Electromagnetic Interference

The way an electromagnetic interference (EMI) from other equipment affects the Viera™ Portable Breast Ultrasound depends on the system's operation mode, image control settings, and the type and level of electromagnetic phenomena. Electromagnetic phenomena may be intermittent, making it difficult to identify the source.



If you experience EMI, use caution if you continue using the system, or consider relocating your system.

The following table describes typical interferences seen in imaging systems. It is impossible to describe all manifestations of interference, because it depends on many parameters of the transmitting equipment, for example, the type of modulation used by the signal carrier, the source type, and the transmitted level. It is also possible for the interference to degrade the imaging system's performance and become invisible on the image. If the diagnostic results are suspicious, confirm the diagnosis using other methods.

Imaging Mode	ESD1	RF2	Power Line3
B-Mode	Change of operating mode, system settings, or system reset. Brief flashes in the displayed or recorded image.	For sector imaging scanners, white radial bands or flashes in the center lines of the image. For linear imaging scanners, white vertical bands, sometimes more pronounced on the sides of the image.	White dots, dashes, or diagonal lines near the center of the image.

Possible causes of electrostatic interference:

- ESD caused by charge buildup on insulated surfaces or persons.
- RF energy from portable phones, hand-held radios, smart devices, commercial radio, and TV stations.
- Conducted interference on power lines, switching power supplies, electrical controls, and lightning.

Separation Distance

Recommended Separation Distance

The following table shows recommended separation distances for the system to be kept away from any RF-transmitting equipment. To reduce the risk of interference, when using portable and mobile RF communications equipment, follow the recommended separation distance (calculated from the equation applicable to the frequency of the transmitter). Ensure that field strengths from fixed RF transmitters, as determined by an electromagnetic site survey, are less than the compliance level in each frequency range as noted in the table.

Field strength is difficult to predict theoretically with accuracy if they come from fixed transmitters, such as base stations for radio (cellular/cordless) telephones and land mobile radios, amateur radio, AM and FM radio broadcast, and TV broadcast. To assess the electromagnetic environment from fixed RF transmitters, consider conducting an electromagnetic site survey. If the measured field strength in the location in which the system

is used exceeds the applicable RF compliance level in the table, observe the system to verify normal operation. If abnormal performance is observed, apply additional measures, such as reorienting or relocating the system.



At 80 MHz and 800 MHz, the higher frequency range applies.

The recommended separation distance guidelines in the following table may not apply to all situations. Electromagnetic propagation is affected by absorption and reflection from structures, objects, and people.

The table here provides guidance on conducted and radiated interference from portable and fixed RF transmitting equipment.

RECOMMENDED SEPARATION DISTANCES BY TRANSMITTER FREQUENCY

Rated Maximum Output Power of Transmitter (Watts)	150 kHz to 80 MHz	80 to 800 MHz	800 MHz to 2.5 GHz
0.01	0.35 m (13.8 in)	0.12 m (4.7 in)	0.23 m (9.1 in)
0.1	1.1 m (3.6 ft)	0.38 m (15 in)	0.73 m (28.7 in)
1	3.5 m (11.5 ft)	1.2 m (3.9 ft)	2.3 m (7.5 ft)
10	11 m (36.1 ft)	3.8 m (12.5 ft)	7.3 m (24 ft)
100	35 m (114.8 ft)	12 m (39.4 ft)	23 m (75.5 ft)

For example, if a portable transmitter has a maximum radiated power of 1 W and an operating frequency of 156 MHz, it can be operated at distances greater than 1.2 m (3.9 ft) from the system. Similarly, a 0.01 W Bluetooth wireless LAN smart device operating at 2.4 GHz should be placed no closer than 0.24 m (9.5 in) from any part of the system.

Avoiding Electromagnetic Interference

An ultrasound system is designed to receive signals at radio frequencies, making them susceptible to interference generated by RF energy sources. Other examples of interference are medical equipment, information technology products, and radio and television transmission towers.

To locate the source, find out if the problem resides with the system or the scanning environment:

- Is the interference intermittent or constant?
- Does the interference show up only with one scanner or with several scanners?
- Do two different scanners operating at the same frequency have the same problem?
- Is the interference present if the system is moved to a different location in the facility?

- Can the EMC coupling path be attenuated? For example, placement of a scanner or printer close to an ECG cable can increase electromagnetic interference. Moving the cable or other medical equipment away from the location of the scanner or printer can result in reduced electromagnetic interference.

If you find the interference's source, please contact Hologic Technical Support.

Regulation of Low-Power Motor for Radio Wave Range

Article 12: Without permission, any company, distributor, or user is not allowed to modify the certified low-power radio frequency motor to change the frequency, power, or original designed features or functions.

Article 14 : The use of low-power radio frequency motor should not affect the airplane safety or disturb legal telecommunication. If any disturbance is found, stop using it immediately. The motor must be improved until the disturbance disappear.

The legal telecommunication refers to wireless telecommunication under regulations. The low-power radio frequency motor must bear the disturbance from legal telecommunication or industrial, scientific, or medical radio wave device.

The use of wireless communication device (5G) between the frequency range 5.25 GHz to 5.35 GHz is limited to indoor use.

References



Compliance Statement

Clarius products comply with international and national standards and laws. Users are responsible for ensuring that the chosen smart device and scanner are compliant with the law in the jurisdiction where the product is used. Clarius meets all regulatory standards listed in this chapter.

The Viera™ Portable Breast Ultrasound

Authorized Representative

European Authorized Representative (AR) Name: Emergo Europe,
The Hague, Netherlands

Product Classification

Classification:

- Device with scanners (internally powered ME equipment):
 - Health Canada: Class III
 - US FDA: Class II
 - EU: Class IIa
 - China: Class II
- Scanners: Type BF applied parts, IP67
- Battery: IP67
- Ordinary Equipment/Continuous Operation

- Non-AP/APG

Product Serial Number

Clarius has assigned a unique serial number on each scanner. This serial number, displayed in the format PT-R-YYMM-zXXXX, is used to track quality control. We will use the serial number L738-A-1703-A0100 as an example to explain how to interpret this.

PT

Scanner type. In our example, this is “L738”.

R

Revision. In our example, this is “A”.

YY

Two-digit year of manufacture. In our example, this is “17”, meaning the year 2017.

MM

Two-digit month of manufacture. In our example, this is “03”, meaning the month of March.

z

Alphabetical counter, from A to Z, resetting to A on the first day of each calendar year. In our example, this is “A”.

XXXX

Four-digit numerical counter starting from 0001, resetting to 0001 on first day of each calendar year. In our example, this is “0100”, meaning the 100th scanner manufactured in this series.

System Specifications

The Viera™ Portable Breast Ultrasound conforms to the following specifications:

- Gray shades: 256 in B-Mode
- Scan lines: Up to 1,024 scan lines
- Pressure, humidity, and temperature limits: These limits apply only to the Viera™ Portable Breast Ultrasound, not to the smart device. It is your responsibility to select a Clarius-compatible smart device that meets the needs of your clinical environment.

	Operating Limits	Storage Limits	Transient Operating Conditions ^a
Pressure	620 hPa to 1060 hPa	n/a	n/a

Humidity	15% to 95%	0% to 95%	15% to 95%.
Temperature	0°C (32°F) to 40°C (104°F)	-20°C (-4°F) to 50°C (122°F)	-20°C (-4°F) to 35°C (95°F)

- a. The conditions under which the scanner can operate, for at least 20 minutes, immediately after being removed from an environment of 20°C (60°F).

To reach an operating temperature of 20°C (68°F), the Viera™ Portable Breast Ultrasound requires approximately 30 minutes to:

- Warm up from a storage temperature of -20°C (-4°F).
- Cool down from a storage temperature of 50°C (122°F).

Maximum scanner surface temperature is:

- Viera™ = 39.4°C (102.92°F)

If the scanner reaches its maximum surface temperature, it automatically shuts down.



This icon, when blue, indicates that the scanner is cool. When this icon is red, it indicates that the scanner is warm. Tapping this icon anytime displays the scanner's surface temperature in degrees Celsius.

For information on storage temperatures see *Storing Scanners* on page 73.

Scanner Specifications

Viera™ Portable Breast Ultrasound

Linear Array Viera™	
Clinical Usage	breast
Size	38.5 mm
Frequency Range	4 – 14 MHz

Standards

Biocompatibility

ANSI/ISO 10993-1:2009 - Biological evaluation of medical devices - Part 1: Evaluation and testing within a risk management process.

Medical devices - Biological evaluation - Part 1: Evaluation and testing GB / T 16886.1-2011

GB / T 16886.5-2016 Biological evaluation of medical devices - Part 5: In vitro cytotoxicity test

GB / T 16886.10-2016 Biological evaluation of medical devices - Part 10: Stimulation and delayed hypersensitivity test

Chemical

REACH 02006R1907:2015-03-23 - REGULATION (EC) No 1907/2006 OF THE EUROPEAN PARLIAMENT AND OF THE COUNCIL of 18 December 2006 concerning the Registration, Evaluation, Authorization and Restriction of Chemicals (REACH), establishing a European Chemicals Agency



The Viera™ Portable Breast Ultrasound meets the minimum requirements for compliance with the European Union's Restriction of Hazardous Substances (RoHS) Directive 2011/65/EU and its amendments.

Electrical Safety

Reference No.	Year	Title
IEC 61157	2013	Standard means for the reporting of the acoustic output of medical diagnostic ultrasonic equipment
IEC 62133	2012	Secondary cells and batteries containing alkaline or other non-acid electrolyte - Safety requirements for portable sealed secondary cells, and for batteries made from them, for use in portable applications
ST/SG/AC.10/11/Rev.5	2009	Recommendations on the transport of dangerous goods - Manual of tests and criteria

Federal

Health Canada's MDR - Medical Devices Regulations SOR-98-282

Labeling

ISO 60417:2014 - Graphical symbols for use on equipment.

Quality

Performance

Reference No.	Year	Title
AIUM/NEMA UD 2-2004	2009	NEMA Standards Publication UD 2-2004 (R2009) Acoustic Output Measurement Standard For Diagnostic Ultrasound Equipment, Revision 3. (Radiology)
AIUM/NEMA UD 3-2004	2009	NEMA Standards Publication UD 3-2004 (R2009) Standard for Real-Time Display of Thermal and Mechanical Acoustic Output Indices on Diagnostic Ultrasound Equipment
ANSI/AAMI ES60601-1	2005/(R)2012 A1:2012 C1:2009(R)2012 A2:2010(R)2012	Medical electrical equipment-Part 1: General requirements for basic safety and essential performance (IEC 60601-1:2005, MOD)
CAN/CSA-C22.2 No. 60601-1-6:11	2011	Medical electrical equipment - Part 1-6: General requirements for basic safety and essential performance - Collateral standard: Usability (Adopted IEC 60601-1-6:2010, third edition, 2010-01)
CAN/CSA-C22.2 No. 60601-1:14	2014	Medical electrical equipment - Part 1: General requirements for basic safety and essential performance (Adopted IEC 60601-1:2005, third edition, 2005-12, including amendment 1:2012, with Canadian deviations)
IEC 60601-1	2012	Medical electrical equipment - Part 1: General requirements for basic safety and essential performance
GB 9706.1	2007	Medical electrical equipment - Part 1: General requirements for safety
GB 9706.9	2008	Medical electrical equipment - Part 2-37: Particular requirements for the safety of ultrasonic medical diagnostic and monitoring equipment
GB 10152	2009	B-mode ultrasonic diagnostic equipment
GB/T 14710	2009	Environmental requirement and test methods for medical electrical equipment.
GB/T 16846	2008	Requirements for the declaration of acoustic output of medical diagnostic ultrasonic equipment
GB/T 191	2008	Packaging and pictorial marking for handling of goods
IEC 60601-1-12	2014	Medical electrical equipment - Part 1-12: Requirements for Medical Electrical Equipment and Medical Electrical Systems Intended For Use in the Emergency Medical Services Environment
IEC 60601-1-2	2014	Medical electrical equipment - Part 1-2: General requirements for basic safety and essential performance - Collateral Standard: Electromagnetic Capability - Requirements and tests
IEC 60601-1-6	2013	Medical electrical equipment - Part 1-6: General requirements for basic safety and essential performance - Collateral Standard: Usability

IEC 60601-2-37	2007	Medical electrical equipment - Part 2-37: Particular requirements for the basic safety and essential performance of ultrasonic medical diagnostic and monitoring equipment
YY 0076	1992	Classification of metal parts coating technology
YY 0505	2012	Medical electrical equipment - Part 1-2: General requirements for safety Collateral standards: EMC requirements and tests
YY 0767	2009	Ultrasound color flow imaging system
YY/T 1420	2016	Environmental requirement and test methods for medical ultrasonic equipment

Risk, Product Specification, Design Review, & Verification/Validation

Reference No.	Year	Title
21 CFR 11	2014	Part 11 Electronics Records and Electronic Signatures
21 CFR 801	2014	Part 801 Labeling
21 CFR 820	2014	Part 820 Quality System Regulation
21 CFR 821	2014	Part 821 Medical Device Tracking Requirements
21 CFR 822	2014	Part 822 Postmarket Surveillance
21 CFR 830	2014	Part 830 Unique Device Identification
BS EN 1041	2013	Information supplied by the manufacturer of medical devices - Medical Device Information
CMDR	2011	Canadian Medical Devices Regulations (CMDR): <ul style="list-style-type: none"> • Safety and Effectiveness Requirements (Sections 10-20) • Labeling Requirements (Sections 21-23)
IEC 62304	2006	Medical device software - Software life cycle processes
IEC 62366	2014	Medical devices - Application of usability engineering to medical devices
IEC/TR 80002-3	2014	Medical device software - Part 3: Process reference model of medical device software life cycle processes
IEEE 11073- 20601a	2010	Health informatics - Personal health device communication. Part 20601: Application profile - Optimized Exchange Protocols
ISO 10993-1	2009	Biological evaluation of medical devices - Part 1: Evaluation and testing within a risk management process
ISO 13485 EN ISO 13485	2016 2016	Medical Devices - Quality Management Systems - Requirements for Regulatory Purposes

ISO 14971 EN ISO 14971	2007 2012	Medical Devices - Application of Risk Management to Medical Devices
ISO 15223-1	2012	Medical devices - Symbols to be used with medical device labels, labeling and information to be supplied
MDD	1993	Medical Device Directive 93/42/EEC ANNEX II
YY/T 0316	2016	Medical Device Risk Management for Medical Device Applications

Security & Privacy

IEC TR 80002-3:2014 - Medical device software - Part 3: Process reference model of medical device software life cycle processes.

Wireless

U.S.

- FCC15.247

Europe

- ETSI EN 300 328:2006-05- Electromagnetic compatibility and Radio spectrum Matters (ERM)
- ETSI EN 301 489-1:2008-02- Electromagnetic compatibility and Radio spectrum Matters (ERM)
- ETSI EN 301 489-17:2009-05- Electromagnetic compatibility and Radio spectrum Matters (ERM)

Doppler Sensitivity

The following table shows the Doppler sensitivity of the Clarius Scanners.

Viera™ Scanner

	Depth (cm)	Flow (mL/sec)
Color/Doppler signal sensitivity	6.2 cm	-
Flow sensitivity at depth	5.1 cm	0.5 ml/sec

Acoustic Output Tables

Viera™ Scanner: B-Mode & M-Mode

**ACOUSTIC OUTPUT REPORTING TABLE FOR TRACK 3:
SCANNER MODEL VIERA™, B-MODE & M-MODE OPERATION**

Index Label		MI	TIS			TIB	TIC	
			Scan	Non-scan		Non-scan		
				$A_{\text{aprt}} \leq 1 \text{ cm}^2$	$A_{\text{aprt}} > 1 \text{ cm}^2$			
Maximum Index Value		1.00	0.235	(a)	-	0.018	(b)	
Associated Acoustic Parameter	$P_{r,3}$ (MPa)	2.66						
	W_o (mW)		9.33	(a)		0.194	(b)	
	min of $[W_{.3}(z_1), I_{TA,3}(z_1)]$ (mW)				-			
	z_1 (cm)				-			
	z_{bp} (cm)				-			
	z_{sp} (cm)	1.90				1.90		
	$d_{\text{eq}}(z_{sp})$ (cm)					0.098		
	f_c (MHz)	7.04	7.04	(a)	-	7.04	(b)	
Dim. of A_{aprt}	X (cm)		1.34	(a)	-	1.34	(b)	
	Y (cm)		0.450	(a)	-	0.450	(b)	
Other Information	PD (μsec)	0.180						
	PRF (Hz)	9600						
	$p_r@PII_{\text{max}}$ (MPa)	4.21						
	$d_{\text{eq}}@PII_{\text{max}}$ (cm)					0.098		
	Focal Length	FL_x (cm)		2.00	(a)	-		
		FL_y (cm)		4.00	(a)	-		
$I_{pa,3}@MI_{\text{max}}$ (W/cm^2)	285							
Operating Control Conditions	Control 1		MI					
	Control 2			B TIS				
	Control 3					M TIB		
	Control 4							
	Control 5							

(a) Value < 1; the index is not required for this operating mode.

(b) Intended use does not include transcranial or neonatal cephalic so TIC is not computed.

Control 1: Optimization: B-Mode, M-Mode; Depth: 3–6 cm; PRF for M-Mode is 200 Hz.

Control 2: Optimization: B-Mode; Depth: 3–6 cm.

Control 3: Optimization: M-Mode; Depth: 3–6 cm.

Viera™ Scanner: Color Doppler Mode

**ACOUSTIC OUTPUT REPORTING TABLE FOR TRACK 3:
SCANNER MODEL VIERA™, COLOR DOPPLER OPERATION**

Index Label		MI	TIS			TIB	TIC	
			Scan	Non-scan		Non-scan		
				$A_{aprt} \leq 1 \text{ cm}^2$	$A_{aprt} > 1 \text{ cm}^2$			
Maximum Index Value		0.84	0.159	-	-	-	(b)	
Associated Acoustic Parameter	$P_{r,3}$	(MPa)	1.89					
	W_o	(mW)		8.76	-		(b)	
	min of $[W_{,3}(z_1), I_{TA,3}(z_1)]$	(mW)				-		
	z_1	(cm)				-		
	z_{bp}	(cm)				-		
	z_{sp}	(cm)	1.40				-	
	$d_{eq}(z_{sp})$	(cm)					-	
	f_c	(MHz)	5.08	5.08	-	-	-	(b)
	Dim. of A_{aprt}	X (cm)		2.67	-	-	-	(b)
Y (cm)			0.450	-	-	-	(b)	
Other Information	PD	(μsec)	0.766					
	PRF	(Hz)	5310					
	$p_r@PII_{max}$	(MPa)	2.42					
	$d_{eq}@PII_{max}$	(cm)					-	
	Focal Length	FL _x (cm)		2.00	-	-		
		FL _y (cm)		4.0.0	-	-		
	$I_{pa,3}@MI_{max}$	(W/cm ²)	158					
Operating Control Conditions	Control 1		CFD MI					
	Control 2			CFD TIS				
	Control 3							
	Control 4							
	Control 5							

(a) Value < 1; the index is not required for this operating mode.

(b) Intended use does not include transcranial or neonatal cephalic so TIC is not computed.

Control 1: Optimization: CFD enabled; Depth: 3 cm.

Control 2: Optimization: CFD enabled; Depth: 3 cm.

Viera™ Scanner: Needle Enhance Mode

**ACOUSTIC OUTPUT REPORTING TABLE FOR TRACK 3:
SCANNER MODEL VIERA™, B-MODE OPERATION**

Index Label		MI	TIS			TIB	TIC	
			Scan	Non-scan		Non-scan		
				$A_{aprt} \leq 1 \text{ cm}^2$	$A_{aprt} > 1 \text{ cm}^2$			
Maximum Index Value		1.08	0.198	-	-	-	(b)	
Associated Acoustic Parameter	$P_{r,3}$	(MPa)	2.48					
	W_o	(mW)		10.4	-		(b)	
	min of $[W_{,3}(z_1), I_{TA,3}(z_1)]$	(mW)				-		
	z_1	(cm)				-		
	z_{bp}	(cm)				-		
	z_{sp}	(cm)	1.90				-	
	$d_{eq}(z_{sp})$	(cm)					-	
	f_c	(MHz)	5.24	5.24	-	-	-	(b)
	Dim. of A_{aprt}	X (cm)		1.92	-	-	-	(b)
Y (cm)			0.450	-	-	-	(b)	
Other Information	PD	(μ sec)	0.454					
	PRF	(Hz)	2400					
	$p_r@PII_{max}$	(MPa)	3.50					
	$d_{eq}@PII_{max}$	(cm)					-	
	Focal Length	FL_x (cm)		1.90	-	-		
		FL_y (cm)		4.0.0	-	-		
$I_{pa,3}@MI_{max}$	(W/cm^2)	314						
Operating Control Conditions	Control 1		MI					
	Control 2			TIS				
	Control 3							
	Control 4							
	Control 5							

(a) Value < 1; the index is not required for this operating mode.

(b) Intended use does not include transcranial or neonatal cephalic so TIC is not computed.

Control 1: Optimization: Needle Mode Enabled; Depth: 1–7 cm.

Control 2: Optimization: Needle Mode Enabled; Depth: 1–7 cm.

Control Effects Guidance Documents

For more information about ultrasonic bioeffects and related topics, see the following:

- “Bioeffects and Safety of Diagnostic Ultrasound.” AIUM Report, January 28, 1993.
- “American Institute of Ultrasound in Medicine Bioeffects Consensus Report.” Journal of Ultrasound in Medicine, Volume 27, Issue 4, April 2008.
- Third Edition of the AIUM Medical Ultrasound Safety brochure, 2014.
- Information for Manufacturers Seeking Marketing Clearance of Diagnostic Ultrasound Systems and Scanners. FDA, September 2008.
- WFUMB. “Symposium on Safety of Ultrasound in Medicine: Conclusions and Recommendations on Thermal and Non-Thermal Mechanisms for Biological Effects of Ultrasound.” Ultrasound in Medicine and Biology, 1998: Volume 24, Supplement 1.
- Information for Manufacturers Seeking Marketing Clearance of Diagnostic Ultrasound Systems and Scanners, FDA, 2008.
- Medical Ultrasound Safety, American Institute of Ultrasound in Medicine (AIUM), 2014.
- Acoustic Output Measurement and Labeling Standard for Diagnostic Ultrasound Equipment, American Institute of Ultrasound in Medicine, 1993.

Cleaners & Disinfectants

Cleaner & Disinfectant Usage

The following table lists the cleaners and disinfectants compatible with your Viera™ Portable Breast Ultrasound and accessories. The products listed in the following table are chemically compatible and have been tested for efficacy.

Product	Qualified Use^a	Clarius Scanner	Clarius Fan
CaviWipes	LLD, ILD	✓	✓
CIDEX® OPA	HLD	✓	

a. CL = Cleaner, HLD = High-level disinfectant, ILD = Intermediate-level disinfectant, LLD = Low-level disinfectant, S = Sterilant

You may also use products not specifically listed in the compatibility table but with similar active ingredients, as indicated in this list, and marketed for medical use.

Because of the large number of available cleaners and disinfectants, it is impossible to have an all-inclusive list. If you are unsure of the suitability of a particular product, please contact Hologic Technical Support for more information.

Cleaner & Disinfectant Details

Solution	Origin ^a	Usage	Active Ingredients
CaviWipes	US	Wipe	Alcohol, Quaternary Ammonia
CIDEX® OPA	US	Soak	Ortho-phthalaldehyde

a. CA = Canada, US = United States, UK = United Kingdom

Known Issues

For a list of currently known issues with the Viera™ Portable Breast Ultrasound, see www.clarius.me/known-issues.

Glossary of Terms

For ultrasound terms not included in this glossary, refer to Recommended Ultrasound Terminology, Third Edition, published by AIUM.

Acoustic Outputs

A_{aprt}

Area of the active aperture measured in cm^2 .

$d_{eq}(z)$

Equivalent beam diameter as a function of axial distance z , and is equal to $[(4/\pi)(W_o/I_{TA}(z))]^{0.5}$, where $I_{TA}(z)$ is the temporal-average intensity as a function of z in centimeters.

$d_{eq}@PII_{max}$

Equivalent beam diameter at the point where the free-field, spatial-peak pulse intensity integral is a maximum in centimeters.

depth

Refers to the depth of the display. A constant speed of sound of 1538.5 meters/second is assumed in the calculation of echo position in the image.

Dim. of A_{aprt}

Active aperture dimensions for the azimuthal (x) and elevational (y) planes in centimeters.

 f_c

The center frequency (MHz). For MI, f_c is the center frequency associated with the transmit pattern giving rise to the global maximum reported value of MI. For TI, for combined modes involving transmit patterns of unequal center frequency, f_c is defined as the overall range of center frequencies of the respective transmit patterns.

in situ

In the natural or original position.

FL

Focal length, or azimuthal (x) and elevational (y) lengths, if different measured in centimeters.

 $I_{\text{pa.3@MI}_{\text{max}}}$

Derated pulse average intensity at the maximum MI in units of W/cm^2 .

 $I_{\text{SPTA.3}}$

Derated spatial peak, temporal average intensity in units of milliwatts/ cm^2 .

 $I_{\text{SPTA.3z1}}$

Derated spatial-peak temporal-average intensity at axial distance z_1 in units of milliwatts/ cm^2 .

 $I_{\text{TA.3}(z_1)}$

The derated spatial-peak temporal-average intensity at axial distance in units of milliwatts/ cm^2 .

MI (mechanical index)

An indication of the likelihood of mechanical bioeffects occurring. The higher the MI, the greater the likelihood of mechanical bioeffects.

PD

Pulse duration (microseconds) associated with the transmit pattern giving rise to the reported value of MI.

$P_{r,3}$

Derated peak rarefactional pressure associated with the transmit pattern giving rise to the value reported under MI in units of megapascals.

 $p_r@PII_{max}$

Peak rarefactional pressure at the point where the free-field, spatial-peak pulse intensity integral is a maximum in units of megapascals.

PRF

Pulse repetition frequency associated with the transmit pattern giving rise to the reported value of MI in Hertz.

TI (thermal index)

The ratio of total acoustic power to the acoustic power required to raise tissue temperature by 1°C (1.8°F) under defined assumptions.

TI type

Applicable thermal index for the scanner, imaging mode, and exam type.

TI value

Thermal index value for the scanner, imaging mode, and exam type.

TIB (bone thermal index)

A thermal index for applications in which the ultrasound beam passes through soft tissue and a focal region is in the immediate vicinity of bone. TIB non-scan is the bone thermal index in the non-autoscanning mode.

TIC (cranial bone thermal index)

A thermal index for applications in which the ultrasound beam passes through bone near the beam entrance into the body.

TIS (soft tissue thermal index)

A thermal index related to soft tissues.

 TIS^{scan}

The soft tissue thermal index in an auto-scanning mode.

 $TIS^{non-scan}$

The soft tissue thermal index in the non-autoscanning mode.

 $W_3(z_1)$

Derated ultrasonic power at axial distance z_1 in units of milliwatts.

W₀

Ultrasonic power, except for TIS_{scan} , in which case it is the ultrasonic power passing through a one-centimeter window in units of milliwatts.

z₁

Axial distance corresponding to the location of maximum $[\min(W_3(z), I_{TA,3}(z) \times 1 \text{ cm}^2)]$, where $z \geq z_{bp}$ in centimeters.

Z_{bp}

1.69 (A_{aprt}) in centimeters.

z_{sp}

For MI, the axial distance at which pr_3 is measured. For TIB, the axial distance at which TIB is a global maximum (for example, $z_{sp} = z_{b,3}$) in centimeters.

z@PII_{.3max}

The axial distance corresponding to the maximum of the derated spatial-peak pulse intensity integral (megapascals).

Acoustic Artifacts

Acoustic saturation

Occurs when received signals reach a system's high-amplitude limit. At that point the system becomes unable to distinguish or display signal intensities. At the point of saturation, increased input will not increase output.

Aliasing

Occurs when the detected Doppler frequency exceeds the Nyquist limit. It is characterized on the spectral display by the Doppler peaks going off the display, top or bottom, and then continuing on the other side of the baseline. On the Color display an immediate change in color from one Nyquist limit to the other is seen.

Comet tail

A form of reverberation artifact produced when two or more strong reflectors are close together and have a high propagation speed. In this case, sound does not travel directly to a reflector and back to the scanner, and a strong linear echo appears at the reflector and extends deeper than the reflector.

Enhancement

An increased relative amplitude of echoes caused by an intervening structure of low attenuation.

Focal enhancement (focal banding)

The increased intensity in the focal region that appears as a brightening of the echoes on the display.

Mirror imaging artifact

Most commonly seen around the diaphragm. This artifact results from sound reflecting off another reflector and back.

Mirroring

The appearance of artifacts on a spectral display when there is improper separation of forward and reverse signal processing channels. Consequently, strong signals from one channel mirror into the other.

Multi-path positioning and refraction

Artifacts that describe the situation in which the paths to and from a reflector are different. The longer the sound takes traveling to or from a reflector, the greater the axial error in reflector positioning (increased range). Refraction and multi-path positioning errors are normally relatively small and contribute to general degradation of the image rather than to gross errors in object location.

Propagation speed errors

Occur when the assumed value for propagation speed by the ultrasound system is incorrect. If the actual speed is greater than that assumed, the calculated distance to a reflector is too small, and the reflector will be displayed too far from the scanner. Speed error can cause a structure to be displayed with incorrect size and shape.

Range ambiguity

Can occur when reflections are received after the next pulse is transmitted. In ultrasound imaging, it is assumed that for each pulse produced, all reflections are received before the next pulse is sent out. The ultrasound system calculates the distance to a reflector from the echo arrival time assuming that all echoes were generated by the last emitted pulse. The maximum depth to be imaged unambiguously by the system determines its maximum pulse repetition frequency.

Reverberation

The continuing reception of a particular signal because of reverberation rather than reflection from a particular acoustic interface. This phenomenon is analogous to the effect created by mirrors positioned on opposite walls when an object, a head for instance, is placed between the mirrors. The image of the head is reflected back and forth infinitely between the two mirrors, creating the optical illusion of multiple heads. Reverberations are easily identifiable, because they are equally spaced on the display.

Scattering

Is the diffuse, low-amplitude sound waves that occur when acoustic energy reflects off tissue interfaces smaller than a wavelength. In diagnostic ultrasound, Doppler signals come primarily from acoustic energy back-scattered from red blood cells.

Shadowing

Is the reduction in echo amplitude from reflectors that lie behind a strongly reflecting or attenuating structure. This phenomenon occurs when scanning a lesion or structure with an attenuation rate higher than that of the surrounding tissue. The lesion causes a decrease in beam intensity, which results in decreased echo signals from the structures beyond the lesion. Consequently, a dark cloud behind the lesion image forms on the display. This cloud, or shadow, is useful as a diagnostic clue.

Side lobes (from single-element scanners) and grating lobes (from array scanners)

Cause objects that are not directly in front of the scanner to be displayed incorrectly in lateral position.

Speckle

Appears as tissue texture close to the scanner but does not correspond to scatterers in tissue. It is produced by ultrasound wave interference and results in general image degradation.

Spectral broadening

A display phenomenon that occurs when the number of energy-bearing Fourier frequency components increases at any given point in time. As a consequence, the spectral display is broadened. Spectral broadening can indicate the disturbed flow caused by a lesion, and therefore it is important diagnostically. However, broadening can also result from interaction between flow and sample volume size, in which case it is an artifact.

Speed of sound artifacts

Occur if the sound propagation path to a reflector is partially through bone, and the speed of sound is greater than in the average soft tissue. Echo position registration artifacts will be produced. Reflectors appear closer to the scanner than their actual distance because of this greater speed of sound, resulting in a shorter echo transit time than for paths not containing bone.

Revision History

DOCUMENT REVISION HISTORY

Software Version	Revision Date	Description
2.1.0	December 21, 2016	First official release.
2.1.1	February 14, 2017	Changed name from Clarius Ultrasound App to Clarius App. Added new sections and warnings, replaced screens captures, updated instructions.
2.1.2	March 2, 2017	Added a note about using the scanner's rubber handle.
3.1.0	August 25, 2017	Added information for Color Doppler, Power Doppler, M-Mode, Needle Enhance. Updated Cleaning & Disinfecting chapter and Measurement Accuracy table.

DOCUMENT REVISION HISTORY

4.1.0	February 16, 2018	Added information for virtual scanners, automated heart rate feature, post-capture freeze, prospective/retrospective viewing. Removed auto-deletion feature, Clarius Clip-ons.
-------	-------------------	--



Clarius Mobile Health Corp.
#350 - 3605 Gilmore Way
Burnaby, BC V5G 4X5
Canada
1-778-800-9975
www.clarius.me



03149 - 17 - 10095

Este equipamento opera em caráter secundário, isto é, não tem direito a proteção contra interferência prejudicial, mesmo de estações do mesmo tipo, e não pode causar interferência a sistemas operando em caráter primário.

www.anatel.gov.br

Nome técnico: APARELHO DE ULTRA-SOM

Nome comercial: Clarius Ultrasound Scanner

Registro Anvisa nº: 8011758062

Responsável Técnico: Júlia Zema Parente Pinto / CRF – DF 2508

IMPORTADOR:

Emergo Brazil Import Importação e Distribuição de Produtos Médicos Hospitalares Ltda
SIA Trecho 3, Lotes 2010/2020, 1º Andar, Ed. Myriam - Bairro: Zona Industrial (Guará) CEP:
71.200-030 -Cidade: Brasília / UF: DF
CNPJ: 04.967.408/0001-98
email: brazilvigilance@emergogroup.com

수입업자:

이머고코리아유한회사
서울특별시 구로구 디지털로 34길 55 1407호
구로동, 코오롱사이언스밸리 2차