



Instructions for Use

HOLOGIC®

Rx ONLY U.S. FEDERAL LAW RESTRICTS THIS DEVICE TO SALE BY OR ON THE ORDER OF A PHYSICIAN

Read these instructions completely prior to using the Omni Hysteroscope.

These instructions describe the Omni Hysteroscope, associated sheaths, and outflow channels:

Catalogue number	Product	Catalogue number	Product	Hystero-scope working channel diameter	30° Outflow channel part number	Compatible MyoSure Tissue Removal Devices <i>Note: All Models may not be available in all regions. Contact your Hologic Representative for a list of models available in your region.</i>
REF 60-200-30	Omni 30° Hysteroscope	REF 60-201-30	Omni 30° 3.7mm Diagnostic Sheath	Not Applicable	Not Applicable	Not Applicable
		REF 60-202-30	Omni 30° 5.5mm Operative Sheath	3mm	REF 40-201-30	MyoSure Tissue Removal Device REF 10-401 MyoSure LITE Tissue Removal Device REF 30-401LITE MyoSure REACH Tissue Removal Device REF 10-401FC MyoSure Manual Tissue Removal Device REF 20-401ML
		REF 60-203-30	Omni 30° 6mm Operative Sheath	4mm	REF 50-201XL-30	MyoSure Tissue Removal Device REF 10-401 MyoSure LITE Tissue Removal Device REF 30-401LITE MyoSure REACH Tissue Removal Device REF 10-401FC MyoSure Manual Tissue Removal Device REF 20-401ML MyoSure XL Tissue Removal Device REF 50-501XL MyoSure FMS-XL Tissue Removal Device REF 50-601XL

TABLE 1.

Device Description

The Omni 30° Hysteroscope is intended for use in visualizing the uterine cavity and performing operative hysteroscopy procedures including use with the MyoSure Tissue Removal Device. The Omni 30° Hysteroscope system includes a base scope with compatible sheaths of varying working channel size. The 30° removable outflow channels are intended to be used to provide a fluid outflow lumen for use with Omni 30° 5.5mm and 30° 6mm Operative Sheaths. The 30° removable outflow channels include a sealed entry port to permit the introduction of instrumentation.

The reusable rod lens hysteroscope utilizes rod lenses for visualization and fibers for illumination. The hysteroscope includes Omni 30° 5.5mm and 30° 6mm Operative Sheaths to accommodate the respective MyoSure Tissue Removal Device. (See Table 1.)

The operative hysteroscopy system can be combined with a hysteroscopic fluid management system to provide continuous flow hysteroscopy capability. The hysteroscope is normally coupled to a camera and video display unit for visualization.



The Omni 30° Hysteroscope is a type BF applied part per IEC 60601-1.

Performance Parameters

Scope Working Length	200 mm
Angle of View	30°
Field of View	80°

Indications for Use

The Omni 30° Hysteroscope is used to provide viewing of the cervical canal and the uterine cavity for the purpose of performing diagnostic and surgical procedures.

Diagnostic Hysteroscopy

- Abnormal uterine bleeding
- Infertility and pregnancy wastage
- Evaluation of abnormal hysterosalpingogram
- Intrauterine foreign body
- Amenorrhea
- Pelvic Pain

Operative Hysteroscopy

- Directed biopsy
- Removal of retained products of conception
- Submucous Myomectomy (see Contraindications)
- Transection of intrauterine adhesions
- Transection of intrauterine septa

Contraindications

- Acute pelvic inflammatory disease

Hysteroscopy may also be contraindicated by the following conditions, depending on their severity or extent:

- Inability to distend uterus
- Cervical stenosis
- Cervical/vaginal infection
- Uterine bleeding or menses
- Known pregnancy
- Invasive carcinoma of the cervix
- Recent uterine perforation
- Medical contraindication or intolerance to anesthesia

Contraindications to Hysteroscopic Myomectomy

Hysteroscopic myomectomy should not be undertaken without adequate training, preceptorship, and clinical experience. The following are clinical conditions that can significantly complicate hysteroscopic myomectomy:

- Severe anemia
- Inability to circumnavigate a myoma due to myoma size (e.g., predominantly intramural myomas with small submucous components).

Warnings

- **For use only by physicians trained in hysteroscopy**
- **Suspicion of pregnancy should suggest a pregnancy test before the performance of diagnostic hysteroscopy.**
- **The Omni 30° Hysteroscope system is only to be used in conjunction with accessories that comply with the following safety standards: National/Regional versions of IEC 60601-1, the general safety requirements for medical devices; IEC 60601-1-2, collateral requirements for electromagnetic disturbances; and, as applicable, IEC 60601-2-18, particular safety requirements for endoscope equipment and accessories; and IEC 60601-2-2, particular safety requirements for High Frequency (HF) surgical equipment and accessories. Before using any accessory, be sure to follow the instructions provided with the accessory, including in the case of a HF electrode, the maximum recurring peak voltage rating.**
- **When using HF surgical equipment, keep the working part of the active electrode in the field of view to avoid accidental burns.**
- **The hysteroscope, sheath(s), outflow channel(s) and accessory components are shipped non-sterile. They must be thoroughly cleaned and sterilized before each use.**
- **If each scope light post adapters have been used, they need to be disassembled, cleaned, and sterilized before every subsequent use.**
- **Uterine perforation can result in possible injury to bowel, bladder, major blood vessels, and ureter.**
- **High energy radiated light emitted from illuminating fiber at the distal end of the scope may give rise to temperatures exceeding 106°F/41°C (within 8mm in front of the scope). Do not leave tip of scope in direct contact with the patient tissue or combustible materials, as burns may result. Lower the light source output when working in close proximity to the object.**
- **The hysteroscope light post and adapter may exceed temperatures of 41°C. Hysteroscopes should not be placed on the patient or on combustible materials, as burns may result.**
- **To prevent potential safety hazard to the patient caused by accidental loss of function of the device (i.e., front end damage by surgical instruments) it is recommend to have an additional sterile “stand-by” device during surgical procedures.**
- **When scopes are used with laser equipment, appropriate filtering spectacles must be worn by the operating team. In some cases, a specific filter must be put between the scope and camera head to prevent camera damage by high-power laser radiation. Contact your laser supplier for details.**

To prevent scope damage by high-power laser radiation, always ensure that the laser delivery fiber is seen through the scope and not directed at the scope before energizing the laser.

For Continuous Flow Hysteroscopy:

- If liquid distension medium is used, strict fluid intake and output surveillance should be maintained. Intrauterine instillation exceeding 1 liter should be followed with care due to the possibility of fluid overload.

Potential Complications of Continuous Flow Hysteroscopy:

- Hyponatremia
- Hypothermia
- Uterine perforation resulting in possible injury to adjacent anatomy
- Pulmonary edema
- Cerebral edema

Precautions

- Vaginal ultrasonography before hysteroscopy may identify clinical conditions that will alter patient management.
- Intrauterine distension can usually be accomplished with pressures in the range of 35–75mm Hg. Unless the systemic blood pressure is excessive, it is seldom necessary to use pressures greater than 75–80mm Hg.
- Do not use the seals if the sterile package is open or appears compromised. Do not use the device if damage is observed.
- Avoid exposing the scope to sudden temperature changes. Do not immerse hot scopes into cold water or liquid.
- Any mechanical manipulation of the eyepiece may result in seal breakage, therefore do not attempt to remove the eyepiece.
- Avoid contact with metal parts of the scope and other conductive accessories by ensuring before activation of the HF output that the active electrode is at a sufficient distance from the tip of the scope.
- To avoid perforation, do not use the scope tip as a probe and exercise caution when the scope is being inserted through the cervix and when the scope tip is near the uterine wall.

 These devices contain the hazardous substance Lead (Pb) in excess of the allowable amount within the REACH Regulation (EC 1907/2006). Lead may damage fertility or the unborn child, causes damage to organs through prolonged or repeated exposure, is very toxic to aquatic life with long lasting effects, may cause cancer, is very toxic to aquatic life and may cause harm to breast-fed children.

Inspection Prior to Use

Prior to each use, the outer surface of the insertion portion of the hysteroscope, sheath(s) and outflow channel(s) should be inspected to ensure there are no unintended rough surfaces, sharp edges or protrusions. Check that both the hysteroscope and outflow channel contain seals.

Hysteroscope System Set-up Instructions

The Omni 30° Hysteroscope consists of a base scope (60-200-30), compatible sheaths including an Omni 30° 3.7mm Diagnostic Sheath (60-201-30), Omni 30° 5.5mm Operative Sheath (60-202-30) and Omni 30° 6mm Operative Sheath (60-203-30), and 30° Removable Outflow Channels (40-201-30 and 50-201XL-30) as shown in Figure 1.

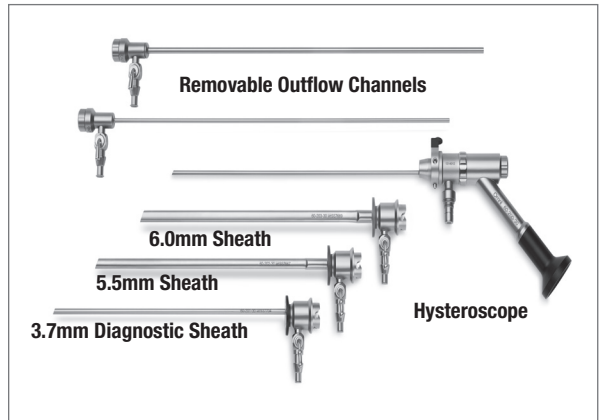

FIGURE 1. REPRESENTATIVE HYSTEROSCOPE & OUTFLOW CHANNEL

To place compatible sheath over base hysteroscope

Using the arrows for orientation, slide the sheath over the exposed rod lens until the end of the sheath engages with the base of the scope and is secure as seen in Figure 2. To release the sheath, push the locking mechanism pin at the base of the scope.

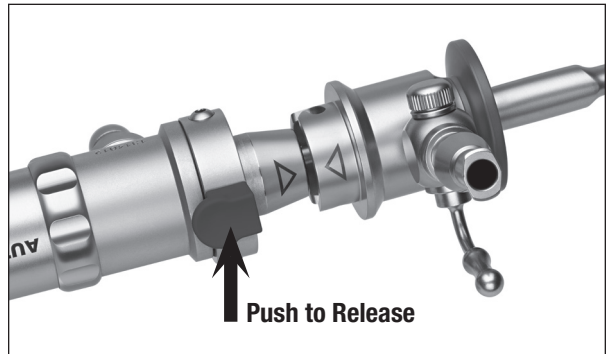

FIGURE 2. SECURE SHEATH

To Insert Sterile Single-Use Seal (40-902):

Both the hysteroscope and the outflow channel contain single-use seals for their working channels. Figure 3 below illustrates the installation of the seals.

Caution: To ensure proper performance of the system and prevent leaks, install new seals in the hysteroscope and the outflow channel prior to use.

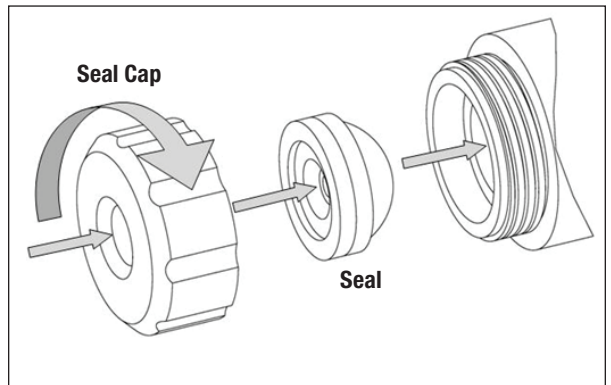

FIGURE 3. SEAL INSTALLATION

ENGLISH

To place removable outflow channel into hysteroscope:

Insert the removable outflow channel into the proximal seal of the hysteroscope working channel. Reverse this process to remove the outflow channel.

To Attach Fluid Connections:

The Omni 30° 3.7mm Diagnostic Sheath, Omni 30° 5.5mm Operative Sheath and Omni 30° 6mm Operative Sheath accept a standard male luer connection for fluid inflow. The 30° Removable Outflow Channel includes a universal stopcock for both luer and friction connections.

Needed Equipment for Indicated Procedures

Fiber optic light source, fiber optic light guide (not supplied with this product)

Hysteroscope Assembly/Disassembly Instructions

The Omni 30° Hysteroscope is compatible with Metal-Halide and Xenon light sources with up to 300 watts of power.

Place the correct adapter on the light post of the fiber optic scope and on the instrument end of the light guide. Adapters are available for connection to Storz, Olympus, Dyonics, Wolf, and ACMI light sources as shown in Figure 4.

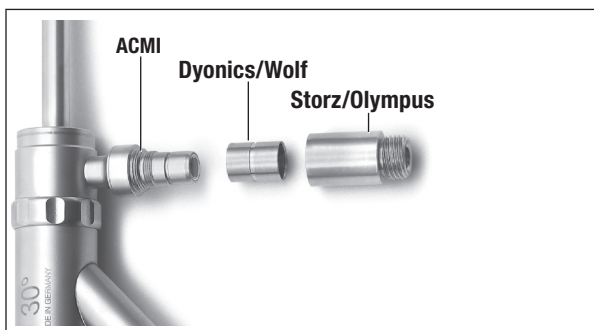

FIGURE 4. LIGHT POST ADAPTERS

The light post threads may be lubricated as needed, being sure to remove any excess lubricant as required. Make sure that the fiber optic surface remains free of foreign matter. Do not use tools to tighten the adapters – hand tighten only.

Directions for Use

The surgeon may look through the direct-view hysteroscope (with eyepiece) directly with his or her eye. If a video system is being connected to the scope, thread a camera coupler onto the camera head and then insert the eyepiece into the camera coupler.

Plug the video cable into the camera control unit (CCU).

Turn on the power to the monitor, CCU, and light source. Adjust the video system components per the manufacturer's instructions. The system is now ready to use.

Hysteroscope Cleaning Instructions—General

The device should not be allowed to dry after procedure before cleaning to ensure effective removal of contaminant material.

- If still inserted, separate the removable outflow channel from the hysteroscope.
- If still attached, separate the sheath from the hysteroscope using the locking mechanism at the base of the hysteroscope.
- Light post Adapters must be removed prior to cleaning and sterilization.

- Remove single-use seals and seal caps from hysteroscope and removable outflow channel(s).
- **Warning: Failure to remove the single-use seals from hysteroscope and removable outflow channels will affect proper cleaning and sterilization of the product.**
- Open the stopcocks on the sheath(s) and removable outflow channel(s).
- Flush all lumens of the hysteroscope, sheath(s) and removable outflow channel(s) with warm tap water.
- Scrub the hysteroscope, sheath(s), and removable outflow channel(s) using a nylon-bristled brush that is suitable to contact the full interior dimensions (diameter and length) of the lumens. Scrub all surfaces, crevices, interior cavities of the stopcock and lumens to remove any visible debris. Do not scratch any of the optical surfaces.
- The following brushes dimensions are recommended
 - For the Omni 30° 5.5mm and 30° 6mm Operative Sheaths, a nylon-bristled brush with bristle area length of 2" (50mm), bristle diameter of 0.315" (8mm) and an overall length of 14" (35cm) is recommended
 - For the Omni 30° 3.7mm Diagnostic Sheath and all other lumens, a nylon-bristled brush with bristle area length of 2" (50mm), bristle diameter of 0.197" (5mm) and an overall length of 14" (35cm) is recommended.
- Utilizing the stopcocks, flush the lumens of the sheath(s) and removable outflow channel(s) with an enzymatic, neutral pH cleaner a minimum of three (3) times ensuring that no air remains within the lumen.
- Flush the lumen of the hysteroscope with enzymatic, neutral pH cleaner a minimum of three (3) times ensuring that no air remains within the lumen.
- Hysteroscope, sheath(s), removable outflow channel(s) and accessory components should be soaked in an enzymatic, neutral pH cleaner in accordance with cleaning solution instructions.
- Thoroughly rinse the hysteroscope, sheath(s), and removable outflow channel(s), including flushing all lumens, and accessory components to completely remove the cleaning solution.
- Dry the hysteroscope, sheath(s), removable outflow channel(s) and accessory components with a lint free soft cloth or filtered compressed air.
- Visually check all surfaces, crevices, interior cavities of the stopcock and lumens.
- Check visually for cleanliness to ensure that all debris have been removed. If not visually clean, repeat the reprocessing steps until the device is visually clean.

Hysteroscope Cleaning Instructions—Optical Surfaces

Due to insufficient cleaning or foreign matter contamination, deposits may develop on the three optical surfaces of the hysteroscope as shown below.

These are:

- The distal tip
- The proximal window or eyepiece
- The fiber optic light post

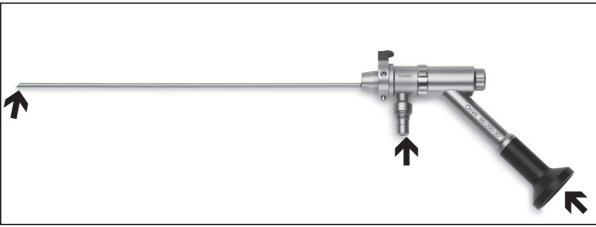

To remove these deposits, a tube of bio-compatible polishing paste is enclosed with each hysteroscope.

To remove the deposits, dab some polishing paste onto a clean, cotton-tipped swab. Gently press the swab onto the optical surface to be cleaned and scrub the surface with a circular motion. Rinse the optical surface with water to remove any remaining polishing paste.

NOTE: Cleaning should only be performed when the image as viewed through the scope is cloudy, and not as part of your routine cleaning procedures.

NOTE: Do not use any ultrasonic cleaning methods. The energy transmitted through fluid cavitations will damage seals and optical surfaces and will void the warranty.

NOTE: Foreign matter remaining on the fiber surface of the light post after cleaning may tend to burn and discolor the surface when exposed to a high intensity light source.

Sterilization

The hysteroscope, sheath(s), removable outflow channel(s), and accessory components should be sterilized prior to use according to the parameters listed below. Be sure the distal working length does not experience any undue forces or stress which can damage the delicate internal optics.

Sterrad®— (100NX Systems – Standard Cycle Setting, 100S System - Short Cycle Setting) Device meets guidelines for Sterrad 100S, and 100NX systems and requires the use of a Sterrad-compatible tray or container system (APTIMAX® tray REF: 13831 or equivalent). Refer to manufacturer’s Instructions for Use for more information. Trays should be wrapped with two layers of a sterilization wrap that is cleared by the FDA for the indicated sterilization cycle (Halyard Health H400 or equivalent).

Steam Autoclave— Prior to sterilization, the hysteroscope, sheath(s), removable outflow channel(s) and accessory components should be prepared in one of the following configuration:

- Double pouched in sterilization pouches that are cleared by the FDA for the indicated sterilization cycle (Cardinal Health pouch CAT #T90009 or equivalent).

Follow standard hospital procedures:

Pre-vacuum method: 132° C (270° F) for a minimum of 4 minutes and 35 minutes dry time.

Gravity method: 132° C (270° F) for a minimum of 15 minutes and 30 minutes dry time.

IMPORTANT: It is recommended that the institution employ procedures which include the use of biological indicators in order to determine the effectiveness of the sterilization process.

Maintenance

We recommend that you inspect the hysteroscope, sheath(s) and outflow channel(s) carefully before and after the procedure for possible signs of damage.

First, check the image quality of the scope by viewing the monitor. If image quality is impaired:

- Check the distal and proximal lenses of the hysteroscope for cracked or scratched lenses.

- Check the surface cleanliness of the distal and proximal lenses. A foggy or cloudy image can be the result of moisture entering the optical system or lack of cleanliness of exterior surfaces. When viewing reflected light, the surfaces should appear smooth and shiny.

As a second step, check the illumination system of the scope. Reduced brightness can result from fiber damage:

- Check for fiber optic damage in the scope by holding the distal end of the scope toward a low power light and observing the light post on the hub. The center of the light post should appear clear or white. Noticeable black spots indicate serious damage to the fiber illumination bundle in the scope. This will affect light transmission and the brightness of the image viewed on the monitor.
- Check the light cable for damaged fibers by holding one end of the cable toward a low power light and observing the other end. Broken fiber will appear as black spots in the light field. A damaged light cable will affect its ability to transmit light and the brightness of the image viewed on the monitor.

Storage

The Omni 30° Hysteroscope System should be stored either in their shipping box or in a sterilization tray. In either case, proper care should be taken to ensure that the base hysteroscope, sheath(s) and outflow channel(s) are immobile to prevent any damage.

Accessories

The following are replacement/service parts or optional accessories to enhance the user experience for the 30° Omni Hysteroscope System:

REF	Description
40-201-30	Replacement Omni 30° Outflow Channel
50-201XL-30	Replacement Omni 30° XL Outflow Channel
ASY-04996	Hysteroscope Light Source Adapters - 1 each: Wolf and Storz
40-902	MyoSure Single Use Seal Set - 10 per box
40-904	MyoSure Hysteroscope and Outflow Channel Seal Cap
60-201-30	Omni 30° 3.7mm Diagnostic Sheath
60-202-30	Omni 30° 5.5mm Operative Sheath
60-203-30	Omni 30° 6mm Operative Sheath
60-911	Omni Spare Part Kit
Optional Accessories	
60-5FR	Omni 5 Fr Seal Cap

WARRANTY, SERVICE, AND REPAIR

WARRANTIES

Except as otherwise expressly stated in the Agreement:

- Equipment manufactured by Hologic is warranted to the original Customer to perform substantially in accordance with published product specifications for one (1) year starting from the date of shipment, or if Installation is required, from the date of Installation (“Warranty Period”);
- digital imaging mammography x-ray tubes are warranted for twenty-four (24) months, during which the x-ray tubes are fully warranted for the first twelve (12) months and are warranted on a straight-line prorated basis during months 13-24;
- replacement parts and remanufactured items are warranted for the remainder of the Warranty Period or ninety (90) days

ENGLISH

from shipment, whichever is longer; iv) consumable Supplies are warranted to conform to published specifications for a period ending on the expiration date shown on their respective packages; v) licensed Software is warranted to operate in accordance with published specifications; vi) Services are warranted to be supplied in a workman-like manner; vii) non-Hologic Manufactured Equipment is warranted through its manufacturer and such manufacturer's warranties shall extend to Hologic's customers, to the extent permitted by the manufacturer of such non-Hologic Manufactured Equipment. Hologic does not warrant that use of Products will be uninterrupted or error-free, or that Products will operate with non-Hologic authorized third-party products.

These warranties do not apply to any item that is: (a) repaired, moved, or altered other than by Hologic authorized service personnel; (b) subjected to physical (including thermal or electrical) abuse, stress, or misuse; (c) stored, maintained, or operated in any manner inconsistent with applicable Hologic specifications or instructions, including Customer's refusal to allow Hologic recommended Software upgrades; or (d) designated as supplied subject to a non-Hologic warranty or on a pre-release or "as-is" basis.

TECHNICAL SUPPORT AND PRODUCT RETURN INFORMATION

Contact Hologic Technical Support for proper disposal of any part of the Omni Hysteroscope System or if the Omni Hysteroscope System fails to operate as intended. If product is to be returned to Hologic for any reason, Technical Support will issue a Returned Materials Authorization (RMA) number and biohazard kit if applicable. Return the Omni Hysteroscope System according to the instructions provided by Technical Support. Be sure to clean and sterilize the product before returning it and include all accessories in the box with the returned unit.

Return used or opened product according to the instructions provided with the Hologic-supplied biohazard kit.

For More Information

For technical support or reorder information in the United States, please contact:



Hologic, Inc.
250 Campus Drive
Marlborough, MA 01752 USA
Phone: 1.800.442.9892 (toll-free)
www.hologic.com

International customers, contact your distributor or local Hologic Sales Representative:

EC REP European Representative
Hologic BV
Da Vincilaan 5
1930 Zaventem, Belgium
Phone: +32 2 711 46 80



© 2018-2021 Hologic, Inc.

Symbols Used on Labeling

Batch code	
Catalogue number	
Use by	
Manufacturer	
Patient contact parts do not contain phthalate	
Serial number	
U.S. federal law restricts this device to sale by or on the order of a physician	
Do not re-use	
Do not re-sterilize	
Sterilized using irradiation	
Consult instructions for use	
Contents	
Non-sterile	
Caution	
Contains hazardous substances	
Date of manufacture	
Type BF applied part	
Temperature limit	

Hologic, Omni, and MyoSure are associated logos are registered trademarks of Hologic, Inc. and/or its subsidiaries in the United States and other countries. All other trademarks, registered trademarks, and product names are the property of their respective owners.