

# SUPERSONIC™ MACH40

Ultrasound Imaging Platform



## SPECIFICATION GUIDE V2

June 2020

PM.EC.087 RevA

## TABLE OF CONTENTS

Overview .....	4
Clinical Applications.....	4
Imaging Modes .....	4
Imaging Features .....	4
Ergonomics .....	4
Workflow .....	5
Revolutionary Architecture & Performance .....	5
Physical System Specifications.....	6
Cart Design and Ergonomics .....	7
Battery UPS.....	7
Control Panel.....	7
Flat-Panel Display and Articulated Arm .....	7
Advanced User Interface Features.....	7
SuperSonic™ MACH 40 Transducers .....	9
Clinical Applications Packages and User Presets .....	11
User Customizable Presets .....	12
Default Image Display Size.....	12
Imaging Modes, Processing Options and Features .....	12
B-mode Imaging.....	12
Color Flow Imaging (CFI), Color Power Imaging (CPI), and Directional Color Power Imaging (dCPI).....	13
Angio PLUS Imaging (CFI, CPI and dCPI).....	14
Pulsed Wave Doppler (PW).....	15
ShearWave™ PLUS Elastography Imaging (SWE PLUS™ Imaging) .....	16
Viscosity PLUS Imaging (Vi PLUS™ Imaging) .....	17
TriVu™ Imaging.....	17
M-mode Imaging.....	18
UltraFast™ Doppler Imaging .....	18
Attenuation (Att PLUS™ Imaging).....	18
& Sound Speed PLUS (SSp PLUS™ Imaging).....	18
Needle PLUS™ Imaging.....	19
Contrast Imaging Mode (CEUS) .....	19
3D Imaging.....	19
Dual Imaging .....	19
Panoramic Imaging.....	19
Composite Imaging Modes.....	20
Image Review Post-Processing and Cine Clip Capture Features.....	20
Cine Clip Capture and Review .....	20
Annotation and Body Markers .....	20
Biopsy Support.....	21
Measurements .....	21
Continue Exam.....	22
Study Review.....	22
Worksheets .....	23
Configurable Reporting.....	24
DICOM & Connectivity .....	25

Cybersecurity and Patient Privacy Features.....	26
System Configuration.....	26
Data Management.....	26
Data Export.....	26
Clinical Data Export.....	27
Peripherals & Ports Printer.....	27
USB/Ethernet Ports.....	27
DVD/CD.....	27
Wireless connectivity.....	27
Video Output.....	27
Footswitch.....	27
Accessories.....	27
Language Support.....	27
Online Services Support.....	27
Electrical/ Environmental Specifications.....	28
Standards Compliance.....	28

# SUPERSONIC™ MACH 40 ULTRASOUND SYSTEM

## COMPLETE PREMIUM ULTRASOUND SYSTEM FROM HOLOGIC FEATURING SUPERB IMAGE QUALITY, SHEARWAVE™ PLUS ELASTOGRAPHY & ULTRAFast™ IMAGING

### OVERVIEW

#### Clinical Applications

Abdominal  
Breast (2D & 3D)  
Genitourinary: Prostate and Scrotum  
Musculoskeletal (MSK)  
Obstetrics & Gynecology  
Pediatric  
Small Parts  
Thyroid  
Transcranial Doppler (TCD)  
Vascular

#### Imaging Modes

B-mode  
M-mode  
Color Doppler: Color Flow, Color Power, and Directional  
Color Power  
Angio PLUS Imaging: PLanewave UltraSensitive Doppler  
Imaging  
UltraFast™ Doppler Imaging  
Pulsed Wave Doppler  
Contrast Imaging (CEUS)  
ShearWave™ Elastography PLUS (SWE PLUS)  
Vi PLUS™ Imaging (Viscosity imaging and quantification)  
TriVu™ Imaging (real-time triplex B-mode, SWE and COL+  
Doppler imaging)  
3D B-mode and 3D SWE™ Imaging  
Needle PLUS™ Imaging

#### Imaging Features

Panoramic Imaging  
Simultaneous Doppler (Duplex and Triplex)  
Wide Sector Imaging (Trapezoid)  
Tissue Harmonic Imaging on all transducers  
SuperCompound (Spatial Compounding)  
SuperRes (Adaptive Filtering)  
TissueTuner (Speed of Sound control)  
B-mode PRF (Reverberation Reduction)

#### Ergonomics

Flat 23-inch Full HD monitor with handle  
Interactive 15.6-inch Full HD Touch Screen  
Multitouch SonicPad™ Touchpad  
Brightness of main monitor and touchscreen adjustable by  
the user  
Electric lift to adjust the control panel height  
Control panel electronically lockable in any position  
Easy to operate and to move  
Programmable Control Panel keys  
3 positions Central Brake  
Large front and back handles



## Workflow

AutoTGC: Automated Time-Gain Compensation Control  
ManualTouch TGC  
Customizable TGC curves per preset  
Retrospective and Prospective clip Capture  
Cine Loop & PW AutoTrace Trim Capability  
Q-Box Elasticity and Viscosity Quantification Tools  
Real-time Elasticity and Viscosity measurement  
B-mode Attenuation measurement  
B-mode Sound Speed measurement  
2D & 3D Volume Measurement Tools  
Labeled Measurements

PW Doppler Baseline and PRF Assist  
Integrated BI-RADS® and Thy-RADS Lexicon  
On-cart Study Review with Append Exam mode  
Configurable ReportBuilder  
JPEG/AVI/PDF Media Export  
Wi-Fi wireless network connection  
High Definition Digital Video Output (Display port)  
Full DICOM modalities suite  
Login/logout features with three levels of rights  
Data encryption at rest and in transit  
Bar code reader

## REVOLUTIONARY ARCHITECTURE & PERFORMANCE

### System Configuration

Component	Performance
<b>Motherboard</b>	Customized Advantech DMS-BE12
<b>Processor</b>	Intel® Xeon E3-1275 V5
<b>Core Speed</b>	3.6 GHz
<b>Number of Cores</b>	4 cores
<b>Graphics Board</b>	NVIDIA QUADRO P2000 with 5 GB RAM
<b>Memory</b>	16 GB DDR4
<b>Monitor</b>	Full HD WIDE 23 inch, 16:9 ratio
<b>Hard Drives</b>	500 GB x 2
<b>Imaging Channels</b>	256 transmit x 256 receive (Through synthetic acquisition)
<b>Video Output</b>	1920 x 1080 High Definition
<b>3D Motor Controller</b>	Integrated (optional)

### Benchmarks

Cold Boot-up time: < 110 seconds  
Shut down time: < 35 seconds  
Transducer selection time (typical): < 1 sec  
Data access time: << 1 sec

## Hardware

High performance hardware configuration to support 2D and 3D operation

Featuring:

- Intel processors
- Ultra-high performances Graphics board
- Multi-thread processing
- 16 GB of RAM
- Two Large capacity Hard Drives

## Software

64-bit Linux based Operating System  
SonicSoftware Beamforming and Scan Conversion  
Plane waves UltraFast™ Imaging for ShearWave™ PLUS  
Elastography, Vi PLUS™ Imaging, Att PLUS™ Imaging,  
SSp PLUS™ Imaging, UltraFast™ Doppler, Angio PLUS  
Imaging, TriVu™ Imaging and Needle PLUS™ imaging  
modes:

- Up to 20 000 frames per second acquisition
- Data transfer rate: > 5 Gbytes/second

## Physical System Specifications

System Height adjustable from 118.6 cm (46.7 in.) to 183 cm (72 in.)

System Depth adjustable from 98.7 cm (38.9 in.) to 120.8 cm (47.6 in.)

System Width: 60.5 cm (23.8 in.)

Able to pass through a 70 cm (28") doorway

Transportation mode to secure monitor and control panel components

Flexible transducer holders preventing shocks

Weight: 112 kg (246 lbs)

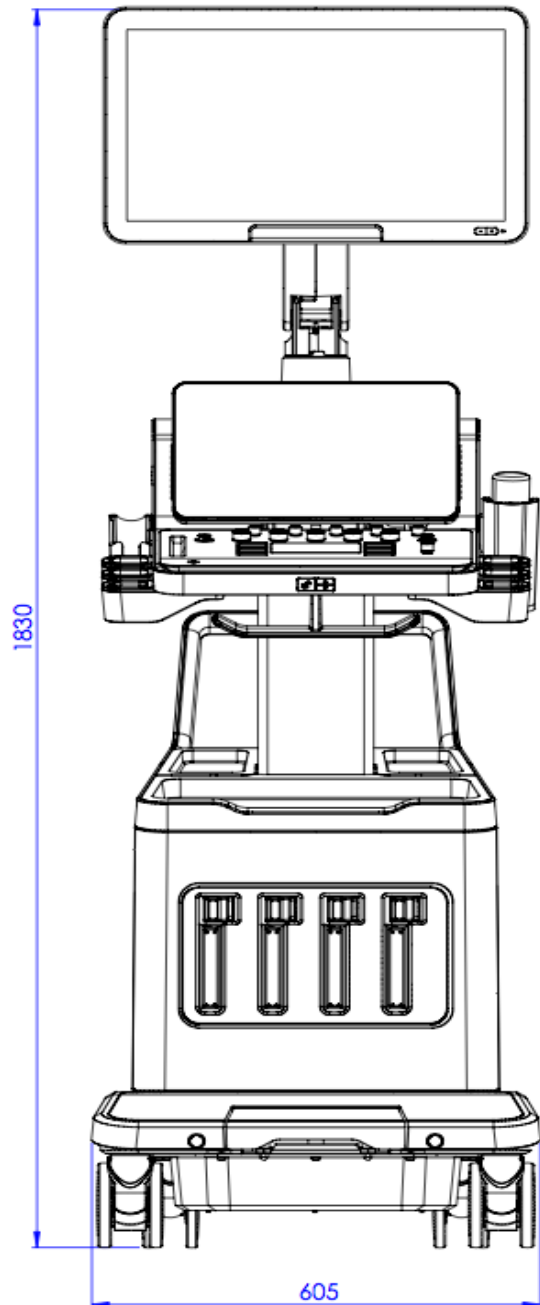

## Cart Design and Ergonomics

### Mobile design:

Adjustable front height handle for improved posture and mobility

Large back handle for transport

Four 5-inch double wheels steering for excellent maneuverability

### 3 Positions Central Brake:

- All unlocked wheels
- Parking with locked front wheels
- Transportation with straight front wheels

Rear wheels braking with 2 swivel locks

Built-in footrest

Four active transducer ports designed for single hand transducer connection

Washable integrated gel warmer

6 large on-cart storage areas

Integrated cable management hooks

Up to 6 transducer holders (compatible with Barcode reader form factor)

Dedicated additional holder for safe storage of endocavitary transducer

Integrated Penholder

### Side bay available for:

- B&W UP-D898DC A6 SONY printer
- CD/DVD writer
- USB ports

Integrated Display Port video output

## Battery UPS

Integrated UPS with high discharge efficiency

Capacity of 360W

The UPS Battery automatically allows:

- The correct operation of the device in case of micro power cuts up to 500 m/s
- The proper extinction of the device in case of main power failure
- The positioning of the control panel in the Parking position even if the device is not powered
- Powering the device for a duration of 5 minutes

## Control Panel

Electrically adjustable control panel height for operator comfort standing and sitting

Vertical adjustment: 75 cm to 99 cm  $\pm$  43° swivel articulation

Control panel electronically lockable in any position

Adjustable control panel color and brightness backlighting

Large simple controls for ease of operation

Configurable control panel buttons location and function

Large SonicPad™ multitouch touchpad for unparalleled ease of operation

Configurable SonicPad™ touchpad gestures for improved workflow

Integrated tiltable 15.6" Full HD capacitive Touch Screen with adjustable brightness

Integrated wrist large rest

Integrated Pen holder

## Flat-Panel Display and Articulated Arm

23" Full HD Color TFT LCD Flat Panel Display

Low-glare hard coating; flicker-free to reduce eyestrain

Ultra-wide viewing angle:  $\pm$ 89° Horizontal &  $\pm$ 89° Vertical

Pixel-sharp high resolution: 1920x1080 @ 60 Hz

Pixel Frequency: 148 MHz

Dot Pitch 0.2652 mm x 0.2652 mm

Display Colors 16.77 million colors, 8 bits for each RGB component

Contrast Ratio: 1000:1

Brightness: 300 cd/m<sup>2</sup> max

Response time: 14 ms

Size of image matrix: 342 x 220 mm

Handle to adjust the monitor using one hand

Monitor is mounted on a fully articulated arm

Tilt from -10° to +90°, rotation of 180° on each side

Height adjustable independently of the control panel

Arm and monitor fold down to reduce overall height to 109 cm (43") for transport

## Advanced User Interface Features

Large 15.6" Full HD capacitive Touch Screen:

- Resolution: 1920 x 1080
- Operates by touch, even with gloves and sheath covered
- Touch-sensitive on-screen keyboard
- Support for 7 keyboard languages: English, German, French, Spanish, Italian, Russian and Swedish

Time-Gain Compensation Controls:

- Touch-sensitive ManualTouchTGC controls
- Up to 11 levels of TGC control in depth dimension
- One push AutoTGC control
- Customizable TGC curve for each preset

#### Fingertip controlled Measurement Calipers:

- Images & clips can be displayed on the Touch screen to perform measurements

#### Interactive Body Markers:

- Fingertip controlled Transducer location using the Touch Screen
- Transducer orientation can be controlled using the SonicPad™ touchpad or rotational knob control



#### SonicPad™ multitouch touchpad 121mm x 82mm (4.8" x 3.3") surrounds:

- Adjust imaging mode gain
- Freeze and Unfreeze
- Save image and Save clip
- Zoom
- Measurements
- Adjust exam depth
- Cine-loop review
- Scroll lists
- Adjust PW sample size & location
- Adjust Color Doppler and SWE box sizes and locations
- Rotate Body markers

- 3D navigation
- Rotate panoramic images
- Scroll imported DICOM volume data

#### Customizable Annotate/Icon key control:

- User-programmable allows the automatic display of Annotation menus or Body Marker menus

#### Two S1 and S2 programmable keys control:

- User-programmable control allows the most commonly used functions to be accessed directly on the control panel

#### Customizable control panel buttons location

- 10 configurable controls



#### Auto Launch upon Freeze:

- User-programmable control allows the most commonly used features to be auto-launched after a Freeze: Annotations, Body Markers, or Measurements.



## SUPERSONIC™ MACH 40 TRANSDUCERS

### L18-5 50mm Linear:

- 256 composite elements
- Effective bandwidth: 5 MHz to 18 MHz
- Transducer footprint: 51 mm
- Ultra-lightweight: 116 grams
- Comfort-hold handle
- 2.1-meter cable
- Pin-less connector for one-handed connect
- Biopsy guide available

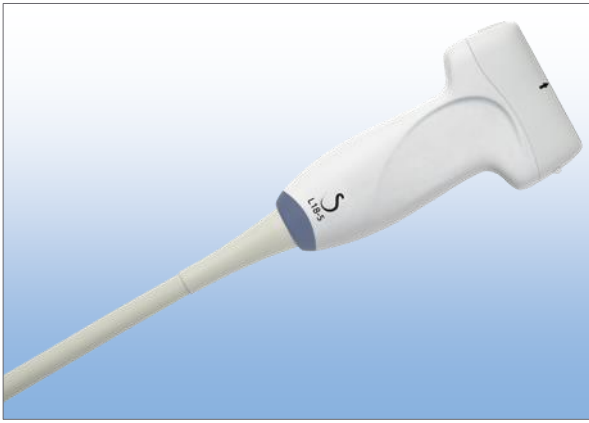

### LV16-5 38mm Linear Volumetric:

- 192 composite elements
- Effective bandwidth: 5 MHz to 16 MHz
- Transducer acoustic footprint: 38 mm x 43 mm (@ 30 degrees)
- 3D Field of View Options: Medium (~10°), Large (~20°), X-Large (~30°)
- Lightweight: 310 grams
- 2.1-meter cable
- Pin-less connector for one-handed connect



### L10-2 38mm Linear:

- 192 composite elements
- Effective bandwidth: 2 MHz to 10 MHz
- Transducer footprint: 38 mm
- Ultra-lightweight: 100 grams
- Comfort-hold handle
- 2.1-meter cable
- Pin-less connector for one-handed connect

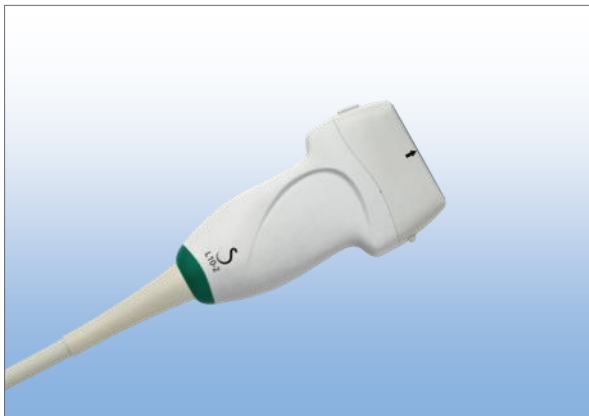

### LH20-6 27mm Linear:

- 192 composite elements
- Effective bandwidth: 6 MHz to 20 MHz
- Transducer footprint: 27 mm
- Ultra-lightweight: 60 grams
- Comfort-hold handle
- 2.1-meter cable
- Pin-less connector for one-handed connect

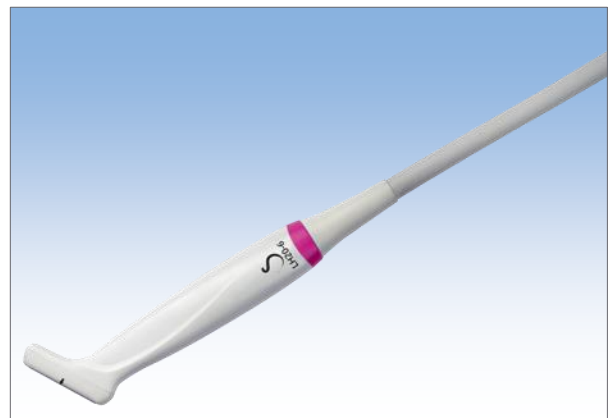

#### **C6-1X Single Crystal Curved:**

- 192 mono-crystal elements
- Effective bandwidth: 1 MHz to 6 MHz
- Transducer footprint: 64 mm
- Field of View: 60° (75° in Wide mode)
- Lightweight: 160 grams
- Ergonomic handle
- 2.1-meter cable
- Pin-less connector for one-handed-connect
- Biopsy guide available



#### **C9-2X Single Crystal Curved:**

- 192 mono-crystal elements
- Effective bandwidth: 2 MHz to 9 MHz
- Transducer footprint: 53.5 mm
- Field of View: 60° (75° in Wide mode)
- Lightweight: 140 grams
- Ergonomic handle
- 2.1-meter cable
- Pin-less connector for one-handed-connect



#### **E12-3 138° Endocavity:**

- 192 composite elements
- Effective bandwidth: 3 MHz to 12 MHz
- Transducer footprint: 28 mm
- Field of View: 138° (170° in Wide mode)
- Lightweight: 210 grams
- Comfort-hold handle
- 2.1-meter cable
- Pin-less connector for one-handed connect
- Biopsy guide available

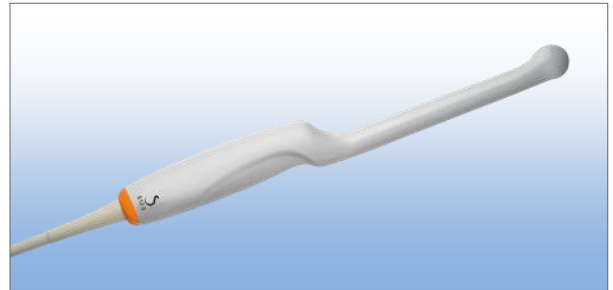

#### **MC12-3 138° Micro-Convex:**

- 192 composite elements
- Effective bandwidth: 3 MHz to 12 MHz
- Transducer footprint: 28 mm
- Field of View: 138° (170° in Wide mode)
- Ultra-lightweight: 60 grams
- Comfort-hold handle
- 2.1-meter cable
- Pin-less connector for one-handed connect



**P5-1X Single Crystal Phased:**

- 96 mono-crystal elements
- Effective bandwidth: 1 MHz to 5 MHz
- Transducer footprint: 19 mm
- Lightweight: 125 grams
- Comfort-hold handle
- 2.1-meter cable
- Pin-less connector for one-handed connect



**CLINICAL APPLICATIONS PACKAGES AND USER PRESETS**

**• Abdominal:**

Abdomen  
Intestine  
Liver  
Abdominal Vascular  
Renal

**• Breast:**

Breast (2D & 3D)  
Breast 2

**• General:**

General (2D & 3D)  
Phantom (2D & 3D)

**• Genito-Urinary:**

Scrotum  
Prostate

**• OB-Gyn:**

Early OB  
General OB  
GYN  
OB

**• Thyroid:**

Thyroid

**• Pediatric:**

Neonatal Head  
Thyroid Neck  
Abdomen  
Hip  
Scrotum  
Superficial  
Pelvis-Gyn

**• MSK:**

Shoulder  
Elbow  
Hand-Wrist  
Knee  
Foot-Ankle  
Muscle

**• Vascular:**

Carotid  
Upper Extremity Arterial  
Upper Extremity Venous  
Lower Extremity Arterial  
Lower Extremity Venous  
Abdominal Vascular  
Transcranial Doppler (TCD)  
Superficial Vascular

Renal

### User Customizable Presets

Up to 12 user-customized presets can be created per clinical application

New Presets can be created based on any existing factory optimized preset or customized preset

“New”, “Update” or “Manage” Presets options are available on the Probe selection screen

New User Presets can be associated with any Clinical Application, and multiple Annotation, Body Marker and Labeled Measurement sets

Custom Presets are Color Coded for enhanced visibility and management

Factory and customized presets can be hidden from the preset selection menu

Selectable order of presets library per application

### Default Image Display Size

Enlarge mode for optimized large size of image when exported to a workstation or a printer

Quick Reset zoom control

Maximum Image size:

1440 x 960 pixels on an area of 34 x 22 cm (13,8 x 8,7 inch)

## IMAGING MODES, PROCESSING OPTIONS AND FEATURES

Imaging channels:

- Transmit channels: 256
- Receive channels: 256 (through synthetic acquisition)

Total Dynamic Range up to 292 dB

Total Processing Channels in UltraFast imaging modes:

- SWE PLUS Imaging & UltraFast™ Doppler: up to 655 million
- Angio PLUS Imaging RT: up to 246 million
- Angio PLUS Imaging HD: up to 459 million
- TriVu Imaging and Vi PLUS Imaging: up to 724 million

### B-mode Imaging

Overall Bandwidth: 90% of transmit frequency on all transducers.

#### L18-5 spatial resolution:

- Axial Resolution < 0.25 mm
- Lateral Resolution < 0.4 mm

#### C6-1X spatial resolution:

- Axial Resolution < 0.5 mm
- Lateral Resolution < 1.3 mm

#### C9-2X spatial resolution:

- Axial Resolution < 0.5 mm
- Lateral Resolution < 1.3 mm

#### E12-3 spatial resolution:

- Axial Resolution < 0.5 mm

- Lateral Resolution < 0.6 mm

#### L10-2 spatial resolution:

- Axial Resolution < 0.5 mm
- Lateral Resolution < 0.5 mm

#### LV16-5 spatial resolution:

- Axial Resolution < 0.25 mm
- Lateral Resolution < 0.5 mm

#### MC12-3 spatial resolution:

- Axial Resolution < 0.5 mm
- Lateral Resolution < 0.6 mm

#### P5-1X spatial resolution:

- Axial Resolution < 0.5 mm
- Lateral Resolution < 2 mm

#### LH20-6 spatial resolution:

- Axial Resolution < 0.25 mm
- Lateral Resolution < 0.3 mm

Basic Imaging Optimization controls:

- Fundamental Imaging
- Tissue Harmonic Imaging
- Resolution / General / Penetration optimization control
- Wide (Trapezoidal) Imaging
- Sector Size Control:  
Wide, Large, Medium, Small

Advanced Imaging Optimization controls:

- SuperCompound Image enhancement
  - Up to 9 beam-steered lines of sight
- SuperRes Image enhancement:
  - Speckle noise reduction and edge enhancement
  - Optimized per transducer and application
  - Up to 6 levels selectable by user
- TissueTuner Speed of Sound Correction
  - Up to 13 different speeds to adapt to tissue type
- B-mode PRF (Reverberation Reduction)
- Manual or Automatic Focal Zone management options
- Auto Adaptive Time-Gain Compensation
  - Automatic TGC/power management ensures B-mode remains TGC balanced across mode and sub-mode changes (Resolution / General / Penetration, THI, color Doppler, etc).

Frame Rate (typical):

- L18-5 > 40 Hz
- C6-1X > 21 Hz
- C9-2X > 23 Hz
- E12-3 > 35 Hz
- L10-2 > 45 Hz
- LV16-5 > 40 Hz
- MC12-3 > 35 Hz
- P5-1X > 40 Hz
- LH20-6 > 55 Hz

B-mode Gain: 0 – 100% of Dynamic Range

Dynamic Range adjustable in 1 dB steps

Dynamic range after amplification: 84 dB

General Gain and Manual TGC adjustable in Frozen Review

Line Density (max): 10 lines/mm

Persistence: 4 levels

Maximum Depth (preset dependent):

- L18-5: 8 cm
- C6-1X: 45 cm
- C9-2X: 35 cm
- L10-2: 12 cm
- E12-3: 22 cm
- LV16-5: 8 cm
- MC12-3: 15.20 cm
- P5-1X: 29.40 cm
- LH20-6: 5 cm

Other information:

- Multiple focal zones: Up to 6
- Focal positions: Up to 8
- Display Gray Levels: 256
- Total Maps: 13 (preset dependent)

- Tinted Maps: 4 (preset dependent)
- HD/Digital Zoom
- Beam Steering Control

**Color Flow Imaging (CFI), Color Power Imaging (CPI),  
and Directional Color Power Imaging (dCPI)**

Bi-directional broadband Doppler Color Flow

Velocity Imaging (CFI)

Broadband Color Power Imaging of Doppler Energy (CPI)

Directional Color Power Imaging (dCPI)

SuperCompound B-mode available in Color Modes

SonicPad™ Color Box size & location control

**L18-5 frequency range: 5.0-9.0 MHz:**

- Axial Resolution: 0.5 mm
- Lateral Resolution: 0.5 mm
- Number of lines: 256 Color + 256 2D lines
- Number of lines in Zoom: 512 lines
- Line Density (max): 5 lines/mm
- PRF Range: 260 - 28000 Hz
- Velocity Range: 2.0 - 72.0 cm/s

**C6-1X frequency range: 2.0-2.5 MHz:**

- Axial Resolution: 2 mm
- Lateral Resolution: 2 mm
- Number of lines: 96 Color + 192 2D lines
- Number of lines in Zoom: 192 lines
- Line Density (max): 3 lines/mm
- PRF Range: 270 Hz - 6600 Hz
- Velocity Range: 5.0 - 103.0 cm/s

**C9-2X frequency range:**

- Axial Resolution: 2 mm
- Lateral Resolution: 2 mm
- Number of lines: 96 Color + 192 2D lines
- Number of lines in Zoom: 192 lines
- Line Density (max): 5 lines/mm
- PRF Range: 240 - 10030 Hz
- Velocity Range: 5.0 - 103.0 cm/s

**L10-2 frequency range: 3.8-6.4 MHz:**

- Axial Resolution: 0.5 mm
- Lateral Resolution: 1 mm
- Number of lines: 192 Color + 192 2D lines
- Number of lines in Zoom: 192 lines

- Line Density (max): 5 lines/mm
- PRF Range: 183 - 29400 Hz
- Velocity Range: 2.0 - 170.0 cm/s

**E12-3 frequency range: 5.0-7.5 MHz:**

- Axial Resolution: 0.5 mm
- Lateral Resolution: 1 mm
- Number of lines: 96 Color + 192 2D lines
- Number of lines in Zoom: 192 lines
- Line Density (max): 3.5 lines/mm
- PRF Range: 260 - 12000 Hz
- Velocity Range: 2.0 - 72.0 cm/s

**LV16-5 frequency range: 5.0-9.0 MHz:**

- Axial Resolution: 0.5 mm
- Lateral Resolution: 0.5 mm
- Number of lines: 192 Color + 192 2D lines
- Number of lines in Zoom: 384 lines
- Line Density (max): 5 lines/mm
- PRF Range: 260 - 18250 Hz
- Velocity Range: 2.0 - 72.0 cm/s

**MC12-3 frequency range: 5.0-7.5 MHz:**

- Axial Resolution: 0.5 mm
- Lateral Resolution: 1 mm
- Number of lines: 48-96 Color+192 2D lines
- Number of lines in Zoom: 96 lines
- Line Density (max): 3.5 lines/mm
- PRF Range: 2000 - 28000 Hz
- Velocity Range: 2.0 - 170.0 cm/s

**XP5-1 frequency range: 2.0-3.0 MHz:**

- Axial Resolution: 1 mm
- Lateral Resolution: 2 mm
- Number of lines: 30 Color + 90 2D lines
- Number of lines in Zoom: 90 lines
- Line Density (max): 1 line/degree
- PRF Range: 100 - 7600 Hz
- Velocity Range: 2.0 - 104.0 cm/s

**LH20-6 frequency range: 6.0-9.0 MHz:**

- Axial Resolution: 0.5 mm
- Lateral Resolution: 0.5 mm
- Number of lines: 48 Color + 192 2D lines
- Number of lines in Zoom: 192 lines
- Line Density (max): 7 lines/mm

- PRF Range: 570 - 18200 Hz
- Velocity Range: 2.0 - 72.0 cm/s

Color Gain: 58 dB

Dynamic Range: 12 - 38 dB (60 dB max)

PRF Range: 260 - 16800 Hz

Velocity Optimization:

- 4 quickset Velocity levels
- Off, Low, Med, High

Color Display Options:

- Color Blending
- Color Flash Suppression
- Color Zoom
- Color Invert
- Hide/Show Color display
- Color & B-mode Side By Side

Display Color Levels: 256

Firing Number per line: 11

Pixel number per line: 1024

Bit number for color coding: 24

Color Maps: Up to 10 (CFI), 8 (CPI)

2nd and 3rd order butterworth Color Wall Filters: 4 levels

Color Smoothing: 7 levels

Color Persistence: 5 levels

Color/B-mode Priority Levels: 0-100%

Focal Zone: Auto set to color box, independent of 2D focal zone

Focal positions: 8

Color Steering:

- Steering angle: -20° to 20° in variable increments (2°, 5°, 10°, 20°)
- Auto-Color Invert with Color Box steering in CFI
- Configurable steering control: Rotation can be set clockwise or counterclockwise

**Angio PLUS Imaging (CFI, CPI and dCPI)**

- PLanewave UltraSensitive Imaging Doppler mode using Plane wave acquisition and UltraFast imaging
- Increased sensitivity and spatial resolution on slow flows
- Available on L18-5 & L10-2 for Breast, Abdomen, Thyroid and MSK applications
- Available on C6-1X & C9-2X for Abdomen, Vascular and Gyn applications
- Adjustable PRF flow velocities (1 cm/s up to 15 cm/s)
- Angio PLUS RT real-time imaging mode

- Very high sensitivity and frame rate using a large color box
- Spectral PW available
- Angio PLUS imaging HD prospective acquisition
  - Activate with a single button
  - Maximum sensitivity and frame rate (up to 160 Hz) even using a large color box
  - Maximum spatial resolution
  - Post processing controls available
- Several Angio PLUS imaging sub-modes available:
  - Color Flow Imaging (CFI)
  - Color Power Imaging (CPI)
  - Color Power Imaging with B-mode signal suppression
  - Directional Color Power Imaging (dCPI)

**L18-5 spatial resolution:**

- Axial Resolution < 0.2 mm
- Lateral Resolution < 0.2 mm

**L10-2 spatial resolution:**

- Axial Resolution < 0.2 mm
- Lateral Resolution < 0.3 mm

**C6-1X spatial resolution:**

- Axial Resolution < 0.4 mm
- Lateral Resolution < 1.2 mm

**C9-2X spatial resolution:**

- Axial Resolution < 0.4 mm
- Lateral Resolution < 1.2 mm

**Pulsed Wave Doppler (PW)**

Pulsed Wave Doppler with Doppler Imaging modes (CFI, CPI & dCPI) in Duplex and Triplex modes

Up to 21 position shifts on linear transducers

High PRF PW Doppler available in all presets including duplex and triplex

Transmit frequency:

- L18-5: 5 Mhz
- C6-1X: 2.1 MHz
- C9-2X: 2.36 MHz
- L10-2: 3.75 MHz
- E12-3: 4.5 MHz
- LV16-5: 5 MHz
- MC12-3: 4.5 MHz
- P5-1X: 1.875 MHz

- LH20-6: 7.5 MHz

FFT Processing: Up to 256 points

FFT Speed: Up to 1920 FFT per second at highest sweep.

4 levels of spectral PW Sweep Speeds:

- Low 33 mm/s
- Med 44 mm/s
- High 67 mm/s
- Max 134 mm/s

PW Total Maps: 9

PW Chroma Maps: 4

2nd and 3rd order butterworth Wall Filters: 3 levels (Low, Med, High) with displayed value in Hz

PRF Range: 200 – 28000 Hz

Dynamic Range: 32 dB (100 dB max)

PW Gain: 0-100% of Dynamic Range

Gain Adjustable in Frozen Review

Quick coarse angle steering: -60°/0°/60°

Fine angle correction: -88° to 88° in 1° steps

Sample Volume size: 0.5 mm to 2 cm

Configurable PW Invert option

Velocity Range (@ 1540m/s):

- L18-5: 6 to 880 cm/s
- C6-1X: 12 to 1400 cm/s
- C9-2X: 12 to 1400 cm/s
- L10-2: 6 to 1160 cm/s
- E12-3: 6 to 1000 cm/s
- LV16-5: 6 to 880 cm/s
- MC12-3: 6 to 1000 cm/s
- P5-1X: 13 to 500 cm/s
- LH20-6: 6 to 350 cm/s

Minimum Detectable Flow Velocity (per wall filter cut-off value):

- L18-5: 0.25 cm/s
- C6-1X: 0.50 cm/s
- C9-2X: 0.50 cm/s
- L10-2: 0.25 cm/s
- E12-3: 0.25 cm/s
- LV16-5: 0.25 cm/s
- MC12-3: 0.25 cm/s
- P5-1X: 0.5 cm/s
- LH20-6: 0.2 cm/s

PW Display Options:

- 5 display formats (full screen trace, side by side, 1/3-2/3, 1/2-1/2, 2/3-1/3)
- Spectral Invert

#### PW Doppler Baseline and Scale Assist

- One-button to adjust baseline and scale

#### PW Doppler Spectral AutoTrace:

- Real-time envelope detection of PW trace
- Sensitivity optimization: Low, Medium, High, Maximum
- Optimization for traces above, below or both sides of baseline
- Mean Trace display
- Velocity measurement points display
- Configurable automated measurements display (PSV, EDV, RI, PI, TAMV, etc.)
- Cycle averaging with cycle select control up to 3 cycles
- Goalposts can be manually set.

#### Full Suite of Measurements including:

- Peak Systolic Velocity
- End Diastolic Velocity
- Minimum Diastolic Velocity
- Resistive Index
- Pulsatility Index
- Systolic/Diastolic Ratio
- Time Average Peak Velocity
- Time Average Mean Velocity
- Acceleration Time
- Acceleration Index
- Pressure Gradient (Peak and Mean)
- Velocity Time Integral
- Volume Flow
- Vessel Diameter and Area
- Doppler Angle
- Sample Volume Depth
- Heart Rate

### **ShearWave™ PLUS Elastography Imaging (SWE PLUS Imaging)<sup>1</sup>**

ShearWave™ Color Box overlay on B-mode image

All B-mode controls are available in SWE PLUS mode

SuperCompound B-mode Image enhancement available in SWE PLUS

SonicTouch MACH cone shear wave generation:

- Real-time
- Low energy transmitted
- Fully automatic; No compression required
- Reproducible

---

<sup>1</sup> SWE PLUS imaging is not available in Vascular and OB applications.

#### UltraFast™ Data Acquisition Technology for SWE PLUS

##### Imaging:

- SWE PLUS Imaging acquisition Data Frame Rate: 20 kHz
- Real-time Display Frame Rate: up to 4 Hz
- Maintain B-mode quality and frame rate

SWE PLUS Imaging Optimization Controls: Resolution, Standard, Penetration

Spatial Resolution of SWE PLUS Imaging (mean of axial and lateral measures):

- L18-5: 1.7 mm
- L10-2: 1.8 mm
- LV16-5: 1.6 mm
- C6-1X: 2 mm
- C9-2X: 2 mm
- E12-3: 2.4 mm
- MC12-3: 2.4 mm
- LH20-6: 1 mm

SWE PLUS Penetration (greater than):

- L18-5: 3.0 cm
- L10-2: 4.5 cm
- LV16-5: 2.8 cm
- C6-1X: 7.5 cm
- C9-2X: 5.5 cm
- E12-3: 3.5 cm
- MC12-3: 3.5 cm
- LH20-6: 2.2 cm

SWE PLUS Imaging Display formats:

- Single
- Dual Side-By-Side
- Dual Top-Bottom
- Overlay (available in TriVu)

SWE PLUS Imaging UI controls:

- User adjustable SWE-box size
- SWE maximum scale
- Spatial Smoothing: 9 levels
- Persistence: 4 levels
- Elasticity Maps: 6
- Gain
- Opacity (0 - 100%)
- Display Unit (kPa or m/s)
- Display Format

SWE PLUS Imaging Quantification:

Q-Box pixel accurate Elasticity quantification

Minimum measurable Q-Box box area: 1mm<sup>2</sup>

Range of Elasticity:

- 0 - 300 kPa (0-10 m/s) typical



- 0 - 1200 kPa (0 - 20 m/s) in MSK preset
- Optimized default Elasticity scale and SWE imaging sequences per application
- Real-time SWE PLUS Imaging measurement displayed in kPa & m/s available on some C6-1X presets
- 8 Q-Box Elasticity tools:
- Q-Box - Single ROI
  - Q-Box Ratio - Compare 2 ROI's
  - Q-Box Trace - Draw freeform ROI
  - Multi Q-Box - Position any number of Q-Box in multiple images for automatic averaged calculations (Average, Median, SD and IQR)
  - Liver Q-Box - Automatic calculations of several Liver stiffness measurements
  - Q-Box series - Automatic calculations of several Spleen or nodule stiffness measurements
  - SWE PLUS Imaging Stability Index - Automatic assessment of SWE PLUS imaging reproducibility and reliability; available on C6-1X & C9-2X/Abdomen presets (except Renal).
  - Real-time SWE Imaging Median and IQR

### Viscosity PLUS Imaging (Vi PLUS™ Imaging)

Available on C6-1X/Abdominal Liver & Abdomen presets, and C6-1X/General/General preset

Shear waves velocity dispersion assessment for Viscosity measurement

Real-time Vi PLUS imaging Color Box overlay on B-mode image and simultaneously to real-time SWE PLUS mode

All B-mode controls are available in Vi PLUS Imaging mode

SuperCompound B-mode Image enhancement available in Vi PLUS Imaging

SonicTouch MACH cone shear wave generation:

- Real-time
  - Low energy transmitted
  - Fully automatic; No compression required
  - Reproducible
- Real-time Display Frame Rate: up to 2.5 Hz
  - Maintain B-mode quality and frame rate

Vi PLUS Imaging Optimization Controls: Resolution, Standard, Penetration

Vi PLUS Imaging Display formats:

- Single Vi PLUS Imaging
- Dual Side-By-Side
- Dual Top-Bottom

Vi PLUS Imaging UI controls:

- User adjustable Vi PLUS imaging-box size
- Viscosity Range (1.0 - 5.0 Pa.s)
- Gain
- Opacity (0 - 100%)
- Display Unit (Pa.s or (m/s)/kHz)
- Display Format

Vi PLUS Imaging Quantification:

Q-Box pixel accurate Viscosity quantification

Minimum measurable Q-Box box area: 1mm<sup>2</sup>

Range of Viscosity:

- 1 - 5 Pa.s (0-5 (m/s)/kHz) typical

Real-time Vi PLUS imaging measurement displayed in Pa.s & (m/s)/kHz available on some C6-1X presets (Abdomen & Liver)

7 Q-Box Viscosity tools:

- Q-Box - Single ROI
- Q-Box Ratio - Compare 2 ROI's
- Q-Box Trace - Draw freeform ROI
- Multi Q-Box - Position any number of Q-Box in multiple images for automatic averaged calculations (Average, Median, SD and IQR)
- Liver Q-Box - Automatic calculations of several Liver viscosity measurements
- Q-Box series - Automatic calculations of several Spleen or nodule viscosity measurements
- Real-time Vi PLUS imaging median (and SWE PLUS imaging) and IQR

### TriVu™ Imaging

- Combine B-mode, SWE PLUS Imaging and UltraSensitive color Doppler imaging into a real-time triplex mode
- Based on PLanewave UltraSensitive Imaging mode using Plane wave acquisition and UltraFast mode
- Maintain B-mode and SWE quality and performance
- Increased sensitivity and spatial resolution of COL+ Doppler similar to Angio PLUS imaging
- Available on L18-5 & L10-2 for Breast and Thyroid applications
- Adjustable PRF flow velocities (1 cm/s up to 16 cm/s)
- Several display format available:
  - Top Bottom
  - Side by side
  - Single (all modes superimposed with opacity control for SWE PLUS imaging and COL+)
- Retrospective optimizations controls:
  - Zoom (up to 500%)
  - Gain and Manual TGC of B-mode

- Gain of COL+ color Doppler
- Hide COL+
- Dynamic Range of COL+
- Opacity of SWE PLUS imaging (from 0 to 100%)
- Opacity of COL+ (from 0 to 100%)
- All SWE PLUS imaging measurements and calculation tools are available in TriVu imaging.

### M-mode Imaging

M-mode imaging is available on:

- All OB-GYN Presets of C6-1X, C9-2X and E12-3
- C6-1X and C9-2X Abdominal/Abdomen

#### C6-1X frequency range:

- Fundamental Imaging: 2.8 - 4.5 MHz
- Harmonic Imaging:
  - Transmit 1.5 – 2.8 MHz
  - Receive 3.0 – 5.6 MHz

#### C9-2X frequency range:

- Fundamental Imaging: 3.2 - 5.5 MHz
- Harmonic Imaging:
  - Transmit 1.75 – 3.25 MHz
  - Receive 3.25 – 6.5 MHz

#### E12-3 frequency range:

- Fundamental Imaging: 3.75 - 9 MHz
- Harmonic Imaging:
  - Transmit 3.75 – 6 MHz
  - Receive 7.5 - 12 MHz

4 levels of spectral M-mode Sweep Speeds:

- Low 33 mm/s (32 mm/s in OB)
- Med 44 mm/s (43 mm/s in OB)
- High 67 mm/s (64 mm/s in OB)
- Max 134 mm/s (128 mm/s in OB)

Total Maps: 12

Chroma Maps: 4

Smoothing: 8 (0 to 7)

PRF: 1000 Hz in Fundamental Imaging, 500 Hz in Harmonic Imaging

Dynamic Range: 35 dB to 80dB

Gain: 0-100% of Dynamic Range linked to B-mode Gain

Gain Adjustable in Frozen Review

M-mode Zone size: 5 mm to max B-mode Depth

M-mode Display Options:

- 3 display formats (side by side, 1/2-1/2, 2/3-1/3)

Acquisition zoom capability

Time markers displayed every 200 ms

Full Suite of Measurements including:

- M-mode Distance
- Heart Rate Measurement

### UltraFast™ Doppler Imaging

UltraFast Doppler unites 2D Doppler at a very high frame rate and PW Doppler with tremendous advantages:

- Capture of Color Flow or Color Power data at frame rates of up to 400 Hz
- Fast processing time, <6 sec typical
- Available on L10-2, L18-5, C6-1X, C9-2X and P5-1X transducers for Abdominal, Pediatric, Vascular and TCD exams
- Capture in all available sub-modes: Color Flow, Color Power and directional Color Power
- Visualize complex flow dynamics in slow motion
- No trade-off between frame rate and color box size
- No time delays in flow dynamics as in conventional Color Flow
- Quad or full screen display of UltraFast™ Color Flow clip, Peak Systolic image, Mean of Velocities and Maximum of Velocities Images
- Allows “PW Anywhere” spectral analysis, with up to 3 sample volumes analyzed simultaneously
- Same sensitivity and quality as conventional Spectral PW
- Adjustable PW Gain, Baseline and Scale in Review
- Adjustable Dynamic Range and Smoothing to optimize spectral Doppler appearance
- Full quantitative measurement capability (PSV, EDV, etc.) with independent AutoTrace or manual measurements
- Automatic save and with retrospective analysis (and re-analysis) of data in Review

### Attenuation (Att PLUS™ Imaging)

#### & Sound Speed PLUS (SSp PLUS™ Imaging)

Available on C6-1X/Abdominal Liver & Abdomen presets, and C6-1X/General/General preset

Quantitative tools based on Plane Waves ultrasound and UltraFast™ mode

- Quantification of the decrease in amplitude of the ultrasound beam as a function of frequency Att PLUS imaging

- Adjustable Att PLUS imaging box
- Automatic beam Sound Speed measurement SSp PLUS imaging
- No compromise on B-mode image quality
- Both Att PLUS & SSp PLUS imaging measured on the same acquisition
- Tissue Aberration Correction embedded into Att PLUS imaging and SSp PLUS imaging algorithms

### **Needle PLUS™ Imaging**

Needle PLUS imaging automatically detects and modelizes in real-time any biopsy needle in a specific display mode

- Available on all applications of L18-5, L10-2 and LH20-6 (except Neonatal Head)
- Alternates Plane Waves sequences (for needle detection) and conventional Ultrasound sequences (for B-mode imaging)
- Biopsy needle is coded in a specific overlay
- Optimized for a range of 14G-25G needles
- No compromise on B-mode image quality and frame rate
- Needle path can be visualized

Needle PLUS imaging controls:

- Orientation
- Needle Path (on/off)
- Needle Gauge
- Needle map: 11
- Persistence
- Opacity
- Edge Enhancement

Controls and settings can be presetable

Needle path visualization enabled by footswitch

### **Contrast Imaging Mode (CEUS)**

CEUS is available in all applications of C6-1X, C9-2X, E12-3 and L10-2: Abdominal, Breast, Genito-Urinary, Gyn, Thyroid, Pediatric, MSK and Vascular

Fully optimized Contrast Imaging mode for leading contrast agents:

- SonoVue® and Lumason® (USA), Bracco
- Sonazoid™, GE Healthcare

Simultaneous acquisition of B-mode and Contrast images in real-time

Low MI B-mode to minimize contrast agent destruction

Pulse inversion and Power modulation technology

On-screen Contrast timer maintained through transducer changes

Up to 5 minutes of streamed prospective cine capture

Independent control of gain, contrast color maps, TGC curves, and Dynamic Range

Flash destruction mode with adjustable duration

Micro-vascular Imaging (MVI) persistence imaging to assess slow micro-vessel perfusion

CEUS data export compatible with Bracco VueBox® off-line software

### **3D Imaging**

3D imaging in B-mode and SWE imaging

Fully optimized Breast and General presets

Volume Sizes on LV16-5: Medium (10°), Large (20°) and X-Large (30°)

Fast volumetric acquisition < 10 seconds

Intuitive 3D navigation via touch screen and control panel

Quad-screen display format with Axial, Transverse and Coronal planes

MultiPlane and MultiSlice display formats

Slab Thickness controls with optimized rendering features

3D B-mode and SWE volume measurements

Save 3D volume loops

On-cart review package with advanced 3D real-time post-processing

Append additional images to any 3D study

### **Dual Imaging**

Full featured Dual Imaging Mode with independent controls and measures in side-by-side and top/bottom display:

- Dual B-mode
- Dual B-mode, Color, Angio PLUS Imaging, SWE PLUS Imaging and Needle PLUS Imaging

Side-By-Side mode available for B-mode and Color real-time visualization in a "dual-like" format

Available retrospectively after image acquisition

### **Panoramic Imaging**

Extended field of view imaging in B-mode on L18-5, L10-2 and LH20-6 transducers

Up to 60 cm of scanning length

Skin-line scaling markers

Curved distance measurement tool

Zoom, pan, rotate, and trim

Fully trimmable from start or end of the panoramic capture

## Composite Imaging Modes

Composite imaging modes include:

- Simultaneous B-mode & Color Flow Imaging (CFI)
- Simultaneous B-mode & Color Power Imaging (CPI)
- Simultaneous B-mode & Directional Color Power Imaging (dCPI)
- Simultaneous B-mode & PW
- Simultaneous B-mode & M-mode
- Simultaneous B-mode & SWE PLUS Imaging
- Simultaneous B-mode & SWE PLUS Imaging & Vi PLUS™ Imaging
- Simultaneous B-mode, Color & PW Doppler
- Simultaneous B-mode & CEUS Imaging
- Simultaneous B-mode & Angio PLUS Imaging (CFI, CPI & dCPI)
- Simultaneous B-mode & Needle PLUS Imaging
- Simultaneous B-mode, SWE PLUS & Color (TriVu Imaging)
- HD Zoom (high-resolution zoom)
  - Available in all imaging modes
  - Up to 512 scan lines of resolution

## Image Review Post-Processing and Cine Clip Capture

### Features

Image post-processing controls available while in frozen review:

**B-mode:** Gain, Dynamic Range, TGC, B-mode Maps, Digital Zoom, SuperRes, Persistence, Measurements, Annotations, and Body Markers

**CFI/CPI/ dCPI:** Gain, Color Map, Color Priority, Hide/Show Color, Blending, Baseline, Invert, Dynamic Range (dCPI), and Digital Zoom

**PW:** Gain, Dynamic Range, Sweep Speed, Smoothing, Display Format, PW Map, Angle Correct, Baseline, Invert, AutoTrace

**M-mode:** Gain, Dynamic Range, Sweep Speed, Smoothing, Display Format, Map, and Contrast

**SWE PLUS Imaging:** Display Format, Opacity, Elasticity Map, Elasticity Range and SWE Unit

**Vi PLUS Imaging:** Display Format, Opacity, Viscosity Range and Persistence

**UltraFast Doppler:** PW Scale, PW Baseline, PW Wall Filter, Spectrogram Invert, PW Map, PW Angle Correction, Color Gain, B-mode Gain, Dynamic Range, Smoothing, Play Spectral data, Add/Remove/Adjust Spectrograms.

**Angio PLUS Imaging RT:** Color Map, Color priority, Side by Side, Hide/Show color, Baseline, Invert, Blending, Dynamic Range (dCPI).

**Angio PLUS Imaging HD:** Gain, Color Map, Color priority, Side by Side; Hide/Show color, Baseline, Invert, Blending, Dynamic Range (dCPI).

**TriVu Imaging:** Color Map, Color Priority, Hide/Show Color, Blending, Baseline, Invert, Dynamic Range (dCPI), Digital Zoom

**Needle PLUS Imaging:** Needle Map, Needle Path, Opacity, Edge Enhancement.

## Cine Clip Capture and Review

Retrospective and prospective cine clip capture

Cine Clip buffer size (select modes):

B-mode: 10 000 frames (approx.)

CFI/CPI: 5 000 frames (approx.)

PW: 5 000 columns (approx.)

Prospective Clip Capture:

- Choice of 2, 5, 10, 30 sec, and 1 minute in conventional modes
- Independent control, up to 5 minutes in CEUS mode

Frame-by-frame image review of clips while frozen  
SonicPad® touchpad play, fast-forward play and frame reverse

Cine Clip frame rate same as acquisition frame rate in all imaging modes (up to 400 Hz in UltraFast Doppler)

Manual Trim capability

Looping capability when scrolling in cine clip

Available in all Imaging modes including Dual

## Annotation and Body Markers

### Annotations:

Full annotations packages optimized for all Applications and Presets

Fully user-customizable text and text-replacement lists per preset

Default settings are optimized for the most commonly used annotations

Customized home cursor position per display format

Text Replacement and Text Replacement Groups

Title Text and Free Text options available

Automatic line wrapping

Intuitive on-screen text editing

Freely re-position annotations

Easily insert words into existing annotations

### **Body Markers:**

Full pictographic body markers packages optimized for all Applications and Presets

Rapidly depict and change transducer orientation directly on the body marker using the touch screen

One-handed transducer orientation marker adjustment using the SonicPad touchpad

Fully user customizable packages and association per imaging preset

### **Biopsy Support**

On-screen biopsy guidelines for the C6-1X and E12-3 transducers

E12-3: Guidelines at 2° and 3°

C6-1X: Guidelines at 14.8°, 20.4°, 26.6° and 33.7°

Biopsy mode disables AutoFreeze to enhance workflow  
Guidelines correspond to appropriate CIVCO, Protek & InnoFine biopsy kits. See Accessories section for details.  
Biopsy Beam Steering Control optimizes angle of incidence to enhance needle visualization during biopsies (Breast, Thyroid and MSK presets)

Can be combined with Needle PLUS mode

### **Measurements**

Available in frozen, dual and clip images

10 unique cursors per image

Unique measurement features:

- Measurements can be performed directly on the touch screen using a fingertip or stylus
- Measurements can be made across Dual images at the same scaling
- Estimated measurements can extend beyond the image area
- Adjustable precision (number of digits)

### **Basic Measurements:**

- Depth (mm or cm)
- Distance (mm or cm)
- M-mode Distance
- Distance Ratio
- Ellipse (major axis, minor axis, area, perimeter)
- Trace (area, perimeter)
- Curved Distance (mm or cm) in Panoramic Imaging only
- Volume by 3 Distances
- Volume by Ellipse + Distance
- Generic Velocity (Vel), Peak Velocity (PSV), End Velocity (EDV), MDV (Minimum Diastolic Velocity)
- Time Average Peak Velocity (TAPV), Time Average Mean Velocity (TAMV)
- % Diameter Reduction
- % Area Reduction
- Doppler Trace for Time & Slope
- Doppler Time
- Q-Box tool with mean, max, min elasticity & viscosity, Standard deviation, depth and Stability Index
- Q-Box Ratio tool to quickly compare tissue elasticity & viscosity values
- Multi-Q-Box tool allows Q-Box placement across multiple images, even across freeze/unfreeze
- Q-Box Trace allows the user to measure using freehand shaped regions
- Body Mass Index calculation
- Heart Rate from M-mode or PW Doppler
- Body Mass Index
- Body Surface Area

### **Advanced Measurements:**

- Volume Flow (Diameter and TAMV)
- ICA/CCA Ratio for Carotid Flow
- Automatic IMT Thickness measurement with optimization and editing control
- Manual IMT measurements
- PW Doppler Spectral AutoTrace
- Pediatric Hip tools (Hip Angle and d:D ratio)
- Congestion Index
- B-mode Ratio Grayscale Comparison Tool to assess Liver to kidney brightness ratio
- Q-Box tools suite to assess shear waves speed and tissue stiffness
- Q-Box tools suite to assess shear waves speed dispersion and tissue viscosity
- SWE PLUS Stability Index for reliability of Liver and Spleen Stiffness measurement assessment

- Real-time SWE PLUS imaging measurement displayed in kPa & m/s available on C6-1X
- Real-time Vi PLUS imaging measurement displayed in Pa.s & (m/s)/kHz available on C6-1X
- Attenuation PLUS measurement on C6-1X  
Range 0.20 - 1.6 dB/cm/MHz
- Sound Speed PLUS measurement on C6-1X  
Range 1450 - 1600 m/s
- ShearWave™ Dispersion ((m/s)/kHz)
- Viscosity (Pa.s)
- Range 0 - 5 Pa.s or (m/s)/kHz

### 3D Measurements:

- 3 Distance Volume, Ellipse and Distance Volume (MultiPlane view)
- Trace Collection Volume (MultiSlice view)
- Measure Then Label Capability
- Measurements can be launched via tools and assigned to a specific label

### Label Then Measure Capability:

- Measurements can be launched directly from a label
- Clearly identify common measurements on screen and in the report
- Common labels available for all clinical applications
- Bi-lateral measurement support for applications (e.g. Vascular) requiring paired measures

### Full Suite of Obstetrics Measurements and Calculations:

- OB table import feature
- Multi-fetus capability (up to 5)
- Last Menstrual Period (LMP), Date of Conception (DOC) or Estimated Date of Delivery (EDD) manual entry and/or calculated
- Date of Delivery Calculations:
  - Estimated Date of Delivery (EDD) from Last Menstrual Period (LMP)
  - Estimated Date of Delivery (EDD) from Date of Ovulation
- Gestational Age estimated from LMP
- GA from measurements (tables and equations)
- Amniotic Fluid measurements and Index calculations
- Average Ultrasound Age (AUA) calculated from measurements
- EDD from AUA and EDD from DOC
- Estimated Fetal Weight from measurements
- Author selection for GA, EFW, Graphing:
  - Hadlock
  - Hellman

- Hill
- Rempen
- Hansmann
- Jeanty
- Merz
- Chitty
- Daya
- CFEF
- ASUM
- Doubilet
- ISUOG (Leung)
- ISUOG (Sahota)
- McLeanan/Schluter
- Robinson/Fleming
- Verburg
- Osaka
- Oken

- Biophysical profile data entry in Report
- Fetal growth charts with standard curves and plotted actual data in reports
- Ob growth trending
- Ob Percentiles
- Z-Scores
- Right and left Ovarian follicle measurement and counting tool (up to 16 follicles)
- Mean Sac Diameter tool

### Continue Exam

User configurable delay to End Exam:

- Midnight same day
- Midnight following day
- Never expires

Re-open an exam after it has been ended

Fully Append-able: Images, Measurements & Annotations

New data is presented in separate series for tracking

Images cannot be deleted to prevent exam tampering

### Study Review

Quick Study Review

- Image thumbnails on main display allow quick review
- Preview, Open or Delete images instantly
- Full Study Review
- Selectable study list with SonicPad touchpad
- Display study images in 1, 2, 6, 12 and 20-up formats
- Replay cine-clips in real-time
- Export images directly to USB in JPEG format
- Export MPEG4 cine-clips directly to USB in High Definition (H264 or compressed format)

- Order of sending and printing corresponding to the sequence of image selection by the user

## Worksheets

### BI-RADS® Clinical Reporting:

Integrated ACR BI-RADS® lexicon available during the current study

- Fully licensed from the American College of Radiology (ACR)
- Available in the Breast clinical application
- Per lesion BI-RADS® reporting: Up to 8 lesions can be characterized per study
- BI-RADS® results, images and measurements are fully integrated into the Report worksheet

### Thy-RADS Clinical Reporting:

Thy-RADS worksheet available during the live study

- Based on input of expert leaders in Thyroid imaging
- Available in the Thyroid clinical application
- Per nodule Thy-RADS reporting: Up to 12 nodules can be characterized per study
- Thy-RADS results, images and measurements are fully integrated into the Report worksheet

### Clinical Report Worksheets for OB:

Three worksheets available to facilitate obstetrical and gynecologic reporting:

- Early OB
- Gen OB
- GYN

Anatomical images with associated lateral measurements  
Patient information automatically populated from study data

Measurements automatically populated via labeled measurements workflow  
Large, easy to read design  
Locations for key biometrics, Trending, Z-scores, Percentiles and Graphs

<b>SUPERSONIC</b> MACH40		BIG JIM 22/01/2020
<b>Exam Report</b>		
Patient: BIG JIM Patient ID: Auplorer 317386938 DoB: 13/07/1992 Gender: Female Height: Study description:	Accession #: Sonographer: Ref MD: Exam start date: 22/01/2020 Weight: BMI:	
<b>Gen OB</b>		

### Fetal Information: Fetus A

Fetus: Fetus A Gestational age: **14w 4d** Average Ultrasound Age: 14w0d  
 LMP: 12/10/2019 GAbymLMP: 14w 4d Estimated Date Delivery by/AJA: 22/07/2020  
 DOC: 26/10/2019 EDD from LMP: 18/07/2020 Date of Conception by/AJA: 30/10/2019  
 EDD: 18/07/2020

### Biometry: Fetus A

Gestational Age measurements  
 Biparietal diameter (BPD): 2.59 cm 35 th % **23rd**d (Hadlock, 1984)  
 Head circumference (HC): 7.98 cm GA 1 th % -2

### Graph: Fetus A

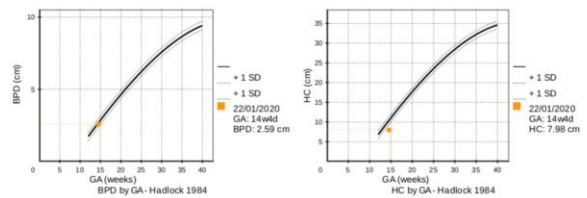

### Report Worksheets for Vascular:

- Carotid
- Upper/Lower Extremity Arterial
- Upper/Lower Extremity Venous
- Abdominal Aorta
- TCD

Anatomical images with associated lateral measurements  
Patient information automatically populated from study data

Measurements automatically populated via labeled measurements workflow  
Large, easy to read design  
Locations for key biometrics BP, ABI, etc.  
SRU/Nascent criteria included for reference  
Toolbox to document Plaque assessment  
Printable on a single paper sheet

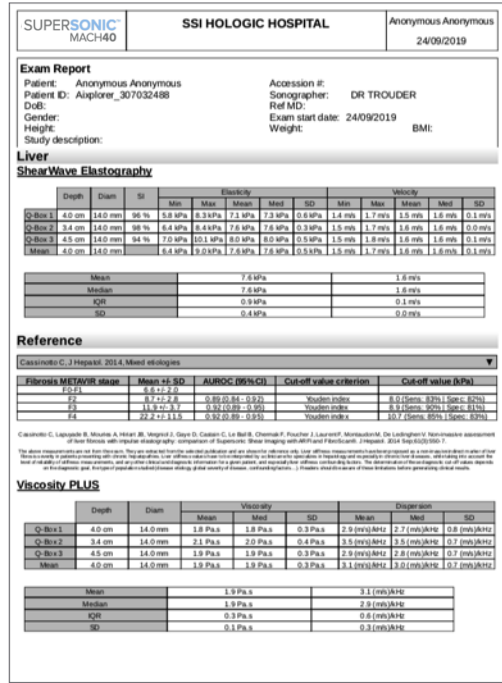
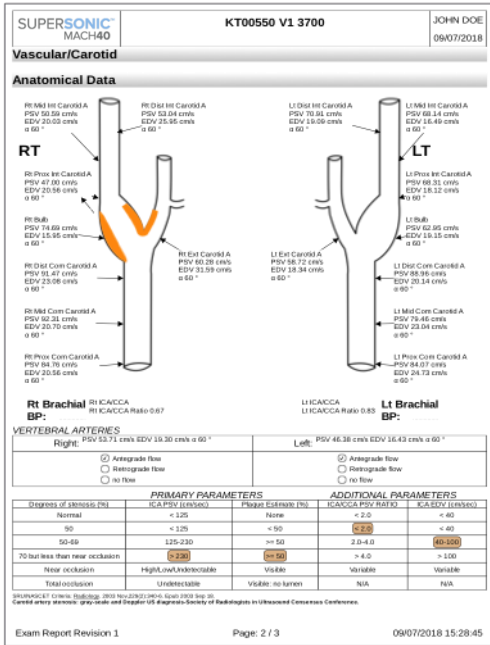

**Report Worksheet for Liver assessment:**

- Includes labeled Q-Box Liver measurements in kPa and m/s
- Includes labeled Att PLUS imaging measurements in dB/cm/MHz
- Includes labeled SSp PLUS imaging measurements in m/s
- Includes Vi PLUS imaging Viscosity and Dispersion measurements in Pa.s and (m/s)/kHz
- Complete Q-Box tools suite for liver and spleen stiffness assessment
- Patient Info and Body Mass Index
- Mean of the Means, Median, Interquartile Range (IQR), SD, depth, Diameter and Stability Index values
- Selection of Liver fibrosis article and cut-off values table per etiology

**Configurable Reporting**

ReportBuilder™ allows the user configurability of the information presented in the Report worksheet:

- User-uploadable hospital logo from USB media for Report header
- Integrated patient history from Patient Data entry screens
- Per image reporting with data reconciliation tools
- Measurements hyper-linked to study images for quick review
- Generous freeform text areas for exam comments and conclusions
- Report preview

- Export reports directly to USB as a Portable Document Format (PDF) file or to DICOM devices as encapsulated PDF files

ReportBuilder configurable components:

- Patient history
- Images
- Measurements
- BI-RADS®
- Thy-RADS
- Carotid, Lower/Upper Extremity Arterial and Venous, Abdominal Aorta Worksheets
- Reports
- Comments
- Selection of Liver fibrosis reference articles with display of cut-off values table

Full Obstetrics Reporting including:

- Hospital and Study Information
- Patient Information and History
- Key Dates such as LMP, EDD, DOC, etc.
- Ob Measurements
- Ob Calculations
- Estimate Fetal Weights and Graphs
- Unlabeled Measurements and Images
- Fetal Biometry Data
- Ovarian Follicle count
- Ob growth trending
- Ob Percentiles
- Z-Scores



## DICOM & Connectivity

10/100/1000 BaseT Ethernet compliant connectivity  
DICOM grayscale or color print  
LUT DICOM GSDF control (12 settings)  
Digital Video Tests Patterns (11 patterns) to aid user in evaluating PACS display monitor calibration  
Selectable order of images to be exported and printed

SuperSonic™ MACH 40 conforms to the following IHE Standards:

- Scheduled Workflow Integration Profile:
- Performed Procedure Step Exception management
- Broad Worklist Query
- Patient Based Worklist Query
- Patient Information Reconciliation Profile
- Consistent Time
- IHE "Connectathon" validated
- IHE profiles: SWF, SWF.B, PIR, PDI, ED, ECHO, ED-ECHO, CT

### DICOM Storage Service Class:

- Allows connectivity to PACS
- Allows "send-as-you-scan", "end of exam" or manual transfer of study data
- Color, Monochrome and mixed Color/Grayscale image export options
- Dedicated DICOM LUTs

### DICOM Modality Worklist (MWL):

- Auto-population of Patient Data Entry screen from hospital HIS/RIS server
- Sort or filter Worklist according to patient information (Name, ID, Date/Time, etc.)
- Capability to manage simultaneously several MWL servers with independent Query configuration
- Show Date/Time of last MWL query in offline mode
- Automatic MWL Query options
- Configurable default Query option (broad, Patient or Last used).
- Patient-based MWL Query options using patient last name, character wildcards, etc.
- 3 MWL update options: Manual, Periodic or Smart update
- Use MWL off-line during portable exams
- Search field can be used with Barcode reader selection to filter by ID.

### DICOM Modality Performed Procedure Step (MPPS):

- System receives and transmits info relating to the patient study and care cycle DICOM Storage Commitment Procedure (SCP)
- Provides commitment from the storage device that study data has been successfully transferred

### DICOM Query and Retrieve (Q/R):

- Query the PACS server for previous exams
- Full native data query and retrieve:
- Ultrasound, Mammography, CT, MRI, X-Ray, Angiography, Nuclear Medicine, Radiofluoroscapy, Computed Radiography, PET
- Retrieve Secondary Capture SOP Class images
- Automatically searches for previous exams of the current patient
- Easy to use search and retrieve tools for any patient
- Automated query and retrieve using MWL patient data
- Filter specific queried image types
- Disable multi-frame image sets for faster retrieve
- Retrieved images can be displayed side-by-side with real-time ultrasound on SuperSonic™ MACH 40
- Easy scrolling through stacked data (MR, CT, PET) using the unique SonicPad™ touchpad control
- Compatible with all DICOM ultrasound images from SuperSonic™ MACH 40 or other vendors
- Push mode capability to push DICOM datasets from a PACS or DICOM modality
- DICOM import from media

### DICOM Structured Report Export (SR):

- Export Ob-Gyn and Vascular labeled measurements to off-line reporting systems
- Compatible with Nuance PowerScribe

### DICOM Compression Options:

- Uncompressed
- JPEG lossless
- JPEG lossy with configurable quality factor
- JPEG-LS lossless
- JPEG-2000 lossless
- Format size reduction

### DICOM Export to Media:

- Export studies in DICOM format to CD/DVD and USB Devices
- Allows "print-as-you-scan" or "end-of-exam" printing to DICOM print devices
- Compatible with the most common DICOM printers (AGFA, KODAK, etc.)

- DICOM Conformance Statement URL:  
https://www.supersonicimagine.com/Aixplorer-R/Connectivity
- Sample DICOM data URL:  
http://www.supersonicimagine.com/Images
- IHE Integration Statement URL:  
https://www.supersonicimagine.com/Aixplorer-R/Connectivity

## Cybersecurity and Patient Privacy Features

Export images with or without patient sensitive identification

“Hide” patient identification on-screen during the exam

Hide/Show Exams control to filter Patient Directory and minimize exposure of sensitive information

Login/Logout capability with three levels of rights:

- Emergency (quick access)
- Sonographer/User
- Administration (extended rights)

Password customizable per login

Data encryption at rest and in transit following TLS (Transport Layer Security) protocol

Audit Trail feature registering user activity and all actions per login

## System Configuration

Personalized Institution Header for Reports

Flexible Regional settings for Language, Keyboard and On-board Help

Screensaver Option

Date & Time can be synchronized via NTP server (up to 3)

Automatic Time Change

Adjustable Control Panel lighting

Adjustable Touch Screen brightness

Adjustable System AutoFreeze Time (4, 6, 8, 10 minutes)

Auto activation of Annotations, Body Markers, or Measurements on Freeze

User-controlled correlation/decorrelation of Color Doppler and PW scales

Configurable Annotations Libraries

Configurable Body Marker Libraries

Configurable Clinical Presets

Configurable Measurement Packages

Metric or English Units

Retrospective Loop length and Compression adjustable

Automatic Hard Disk Maintenance

Connectivity Association and Setups

Diagnostics and Service Access

Medical Staff manager for study association

Anonymous Exam warning

Automated or Manual focal zone adjustment

Auto-Adaptive TGC option

Auto activation of Display of ManualTouchTGC

Enlarge Mode

Control Panel buttons location setup

Gestures setup

Footswitch configuration

Sound Options

Rotation of Depth, Focus and Steering controls

Display of Real-time SWE PLUS imaging and Vi PLUS imaging

Simultaneous display of SWE PLUS imaging alone or SWE

PLUS imaging combined to Vi PLUS imaging

OnLine Services configuration

## Data Management

Internal hard drive(s) for image and data storage

Configuration: 2 hard drives configured for maximum storage and performance

Hard disk capacity: 500 GB x 2

Image storage: 28000 images (estimated)

Study storage: 2800 typical studies (10 images and data)

*Note: UltraFast™ Doppler and Angio PLUS Imaging Data storage may reduce overall system storage capacity.*

## Data Export

Export images to CD, DVD, and USB memory device:

- JPEG image /AVI-H264 Export to USB memory, CD/DVD
- Organized directory structure to quickly find exported studies

Export Reports directly to USB as a Portable

Document Format (PDF) file

Web-based DICOM viewer integrated into all DICOM media exports

Format a USB key on-cart feature

## Clinical Data Export

Export ultrasound study data to facilitate clinical research studies

- Export data from selected studies in the patient directory to removable media (USB)
- Data can be exported in SuperSonic's Users Club (XML) or CSV (Excel) formats

## Peripherals & Ports Printer

USB Thermal image printers supported:

- Sony Black & White model A6 UP-D898DC

Supports Network external plain-paper image/report printers

DICOM Printers: Various

Green Print Capability: 8 print layouts to conserve resources

Selectable order of images to be exported and printed

## USB/Ethernet Ports

Three USB 2.0 and one USB 3.0 ports allow:

- Image export to memory stick or portable hard drive
- Footswitch connection

1 convenience port on rear of control panel

2 ports on right side of cart

1 patient isolated USB 2.0 port

1 USB C-type port

1 patient isolated Ethernet port (100 mbps)

## DVD/CD

Integrated 24x DVD/CD read/write player/burner

Compatible with DVR-R, DVD+R, DVD+RW, DVD-RW, CD-RW and CD-R

## Wireless connectivity<sup>2</sup>

Compliant with 802.11b/g/n standard

WPA/WPA2 Personal security

2.4GHz band frequency

Wi-Fi device FCC/IC/CE certified.

Wireless networking for DICOM modalities and network printer connection.

---

<sup>2</sup> Wi-Fi is not available in all countries.

## Video Output

Integrated Digital Video Output Display Port for secondary display

Native High Definition Output: 1920x1080

## Footswitch

Two-function footswitch:

- Easily connects to any USB port
- Programmable from a set of frequently used operations

## Accessories

Integrated Gel warmer with automatic management of heating up to 37°C

Biopsy Accessories and Kits available through CIVCO, Protek and InnoFine for various transducers: L18-5, L10-2, C6-1X, E12-3, MC12-3



Barcode reader JadaK HS-1M

- Design for healthcare application and environment.
- Durable and cleanable

## Language Support

User Controls supported in five languages: English, French, German, Italian and Spanish

On-screen User's Guide (Help) available in five languages: English, French, German, Italian and Spanish

On-screen keyboards supported in seven languages: English, French, German, Italian, Spanish, Swedish and Russian

## Online Services Support

Remote access to the SuperSonic™ MACH 40 to guarantee a high level of operation and deliver remotely some services to maximize the performances of the device:

- Software updates
- Upload of option files
- Enable temporarily some options
- Capable of retrieving and analyzing logs files
- Run some maintenance & diagnostics tests
- System monitoring to prevent any unexpected behavior of key components

### **Electrical/ Environmental Specifications**

Dual Switching Power Supply

Power consumption:

- 100-240 VAC 50 Hz / 60 Hz, <350 W in standard use.
- Minimum required power: 0.6 kVA.

Temperature Workload < 900 BTU

Temperature Range:

- Operating: 15 - 35°C (59°F - 95°F)
- Storage: -20 to +50°C (-4°F to +120°F)

Humidity Range:

- Operating: 30 - 80%
- Storage: 30 - 80%

Pressure Range:

- Operating: From 700 hPa to 1060 hPa
- Storage: From 500 hPa to 1060 hPa

Optimized cooling fan architecture with minimal audible noise (31.8 dB) equivalent to a bedroom environment

### **Standards Compliance**

Hologic® is ISO 13485 certified.

Hologic® is ISO 14001 certified.

SuperSonic™ MACH 40 is a Medical Device in Class II per the FDA and in Class IIa BF type per the European Medical Directive.

SuperSonic™ MACH 40 is FDA cleared and has received CE Mark approval.

SuperSonic™ MACH 40 conforms to the Digital Imaging and Communications in Medicine (DICOM) standard: 2019c  
SuperSonic™ MACH 40 conforms to WEEE/Rhoos Directives.

SuperSonic™ MACH 40 is compliant with the following Quality Standards for Medical, Electrical, Electromagnetic Interference and General Safety:

- IEC 60601-1, 60601-1-1, 60601-1-2
- 60601-1-6, 60601-2-37
- IEC/EN 61340-5-1, 5-2
- IEC 62304
- EN/ISO 10993-1
- EN/ISO 14971
- EN 50419
- IEC 62366
- NEMA UD 2, UD 3

Internal Protection Marking according to IEC 60529 standard:

IPx0: SuperSonic™ MACH 40

IPx1:

- Footswitch Pedal
- L10-2, L18-5, MC12-3, C6-1X, C9-2X and LV16-5 transducers.

IPx7:

- E12-3, P5-1X and LH20-6 transducers.

**Hologic Headquarters**

**United States / Latin America** 250

Campus Drive

Marlborough, MA 01752

USA Tel: +1.508.263.2900

Sales: +1.781.999.7453

Fax: +1.781.280.0668

Email: [info@hologic.com](mailto:info@hologic.com)

**Hologic Europe**

Everest (Cross Point)

Leuvensesteenweg 250A 1800

Vilvoorde, Belgium

Tel: +32.2.711.4680

Fax: +32.2.725.2087

**Hologic Asia Pacific Limited**

Unit 01-03A, 13/FNo. 909 Cheung Sha

Wan Road Cheung Sha Wan

Kowloon, Hong Kong

Tel: +852 3748 7700

Fax: +852 3526 0723

**Hologic Australia**

Suite 402, Level 4 2 Lyon Park Road

Macquarie Park NSW 2113 Australia

Tel: +61.2.9888.8000

Fax: +61.2.9870.7555

**HOLOGIC.COM**