

# LOCalizer™

## **LOCalizer Reader and RFID Localization System**

User Manual

**R<sub>x</sub> ONLY**

Manufactured for:  
Health Beacons, Inc.  
250 Campus Drive  
Marlborough, MA 01752  
+1 (800) 442-9892

ML-0004 Rev 07

---

**CAUTION:**

Read all warnings, cautions, and instructions provided with this equipment before using.

Read the instructions, warnings, and cautions provided with the Tag Applicator and LOCalizer Surgical Probe before using. Specific instructions pertaining to Tag implantation and preparation and use of the Surgical Probe are not included in this Manual.

**DESCRIPTION****RFID Localization System**

The Tag Applicator, LOCalizer™ Reader, and LOCalizer Surgical Probe are components of the RFID Localization System. The Tag is intended to be placed in breast tissue, within 6 cm of the breast surface, using the Tag Applicator. The Tags, when used in conjunction with the LOCalizer Reader and LOCalizer Surgical Probe, can be used as a guide for the surgeon to follow in the excision of tissue.

RFID Localization System (RFLS) components are listed below:

System Component	Description	Part Number
LOCalizer Reader	RFID Reader	HB100
LOCalizer Surgical Probe	Attachment probe for use with LOCalizer RFID Reader	HB110
Tag Applicator	Needle applicator with preloaded RFID Tag	HB200-XX* HB300-XX*

\* XX indicates the length of the applicator needle in cm. Contact distributor for available sizes in your area.

The LOCalizer Instrument Drape (HB120) is provided separately for use with the LOCalizer Reader in a sterile environment.

**LOCalizer Reader**

The LOCalizer Reader locates and reads (RFID) Tags which have been implanted using the Tag Applicator. The LOCalizer Reader displays the distance between the Tag and the Probe under use. Tag location is also indicated by an audible sound of which the pitch and volume increases in proportion to a decrease in the "LOCalizer to Tag" distance. The LOCalizer Reader is a portable, battery-operated system and is supplied non-sterile. The Tag Applicator and LOCalizer Surgical Probe are provided sterile. This manual includes guidelines for the use of the Probe in the sterile field.

**INDICATIONS FOR USE**

The Tag of the RFLS is intended for percutaneous placement in the breast to mark (>30 days) a lesion intended for surgical removal. Using image guidance (such as ultrasound or radiography) or aided by non-imaging guidance (RFLS), the RFID Tag is located and surgically removed with the target tissue.

The RFLS is intended only for the non-imaging detection and localization of the Tag that has been implanted in a lesion intended for surgical removal.

**CONTRAINDICATIONS**

The RFID Localization System is not intended for use under conditions where breast lesion localization is contraindicated.

The RFID Localization System is not intended for use in the heart, eyes, brain or spinal cord.

The Tag should not be placed in a tissue site with clinical evidence of infection.

The Tag should not be placed in muscle tissue.

**LOCALIZER READER OVERVIEW**

The LOCalizer Reader (*Figure 1*) is composed of:

- 1 Handheld LOCalizer Reader
- 2 AA Alkaline batteries (IEC-LR6)

The LOCalizer Reader includes an integrated Loop Probe (**A**) that is used to locate and read Tags from the skin surface. It can also be used with the LOCalizer Surgical Probe attachment (**D**) to locate and read Tags within the surgical incision. Probe details are included in Table 1. Subsequent sections of this manual describe in detail probe and LOCalizer Reader use.

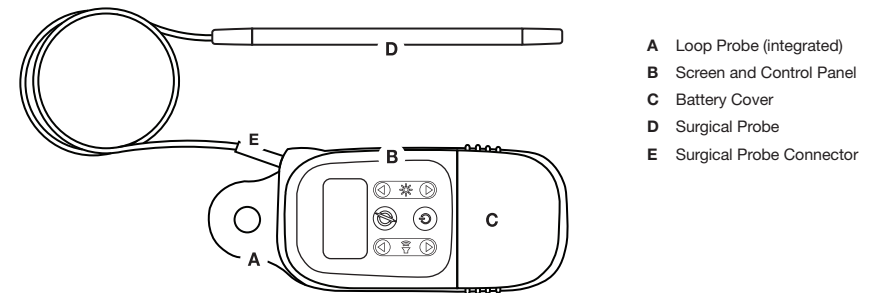

Figure 1. LOCalizer Reader with Surgical Probe connected (Instrument Cover not shown)

Table 1. Probe Specifications

Probe	Part No.	Probe Dimensions	Max Reading Depth
Loop Probe (integrated)	n/a	12 mm inner diameter 39 mm outer diameter	6 cm*
Surgical Probe	HB110	175 mm long 8 mm diameter	3 cm**

\* As measured from center of the Loop probe to end of Tag (Figure 3)

\*\* As measured from end of the Surgical probe to end of Tag (Figure 4)

## WARNINGS

### General

The LOCalizer Reader is designed only for use with the LOCalizer Surgical Probe and Tags.

### Tag Applicator and Surgical Probe

The Tag Applicator is intended for sterile use. Do NOT use this product on a non-sterile surface prior to use internally.

Caution should be exercised with using the device on patients with prostheses so as to not puncture the prosthesis during placement.

If any resistance is felt during advancement of the Surgical Probe or Tag Applicator (during implantation), carefully correct the orientation but never apply strong forces in order to overcome the obstacle.

Exercise caution when placing the Tag near the chest wall. Insert the Needle applicator parallel to the chest wall so as to not puncture the chest wall during placement.

Exercise caution during surgical excision of the lesion to avoid cutting or damaging the Tag. When using electrosurgical tools, avoid direct contact with the Tag as thermal damage can result. If the Tag is inadvertently damaged, ensure all parts of the Tag are retrieved from the surrounding tissue.

When using the Surgical Probe intraoperatively, avoid touching or moving the Tag with the Surgical Probe.

Do NOT use the Tag Applicator or Surgical Probe if the package is open or damaged.

Use the Tag Applicator and Surgical Probe prior to the expiration date shown on the product label.

The Tag Applicator with Tag and Surgical Probe have been designed for SINGLE USE only. Reusing this medical device bears the risk of cross-patient contamination. The residue of biologic material can promote the contamination of the device with pyrogens or microorganisms which may lead to infectious complications.

DO NOT RESTERILIZE. After sterilization, the sterility of the product is not guaranteed because of an indeterminable degree of potential pyrogenic or microbial contamination which may lead to infectious complications. Cleaning, reprocessing and/or re-sterilization of the present medical device increases the probability that the device will malfunction due to potential adverse effects on components that are influenced by thermal and/or mechanical changes.

### LOCalizer Reader

Do NOT use if the package or LOCalizer Reader is damaged.

The LOCalizer Reader is a non-sterile device. Drape with the sterile LOCalizer Instrument Cover (Product HB120) when using in a sterile environment. Do NOT sterilize the LOCalizer Reader as sterility cannot be guaranteed. Cleaning, reprocessing and sterilization of this LOCalizer Reader could cause the LOCalizer Reader to malfunction due to adverse effects on components.

Use of the LOCalizer Reader adjacent to or stacked with other equipment should be avoided because it could result in improper functioning. If such use is necessary, this equipment and the other equipment should be observed to verify that they are operating normally.

Use of accessories, transducers and cables other than those specified or provided by Health Beacons could result in increased electromagnetic emissions or decreased electromagnetic immunity of this equipment and result in improper operation.

The LOCalizer Reader may suffer erroneous signal detection or degraded distance accuracy of an RFID Tag due to electromagnetic interference from HF Surgical Equipment, other RFID readers, or wireless charging devices.

Portable RF communications equipment such as cell phones or tablets should be used no closer than 30 cm (12 inches) to any part of the LOCalizer Reader to avoid degradation of the performance of this equipment.

With the exception of battery replacement, no modification or repair of this equipment by the user is allowed. If the LOCalizer Reader stops working or is damaged it should be replaced.

The user is responsible to maintain FCC compliance. Any changes, modifications, or use of non-Health Beacons probes could void the user's authority to operate the equipment.

## PRECAUTIONS

### General

Failure to thoroughly review and adhere to the information contained in this User Manual may pose a potential hazard to the patient and/or user and may void the warranty.

This product should only be used by a physician who is completely familiar with the indications, contraindications, limitations, typical findings and possible side effects of using a system for lesion localization that employs a marker at the site of the lesion and a reader for marker retrieval.

Handle all components in a manner that will prevent accidental contamination.

### Tag Applicator and Surgical Probe

Do NOT use the Tag Applicator if needle is bent and/or tip is damaged.

Do NOT use the Surgical Probe if it is damaged.

Do NOT remove Safety Lock from applicator until needle has been advanced to desired location for Tag deployment.

Do NOT implant Tag greater than 6 cm deep from the breast surface to accommodate the LOCALizer Reader detection range.

Ensure the Tag is completely deployed in the breast tissue by depressing the plunger until it contacts the Applicator barrel.

After use, the Tag Applicator, Tag, and Surgical Probe are biohazards. Dispose in accordance with your facility's biohazardous waste procedures.

Do NOT immerse the Surgical Probe in liquid.

### LOCALizer Reader

The LOCALizer Reader is designed to locate the low frequency 134 kHz Health Beacons Tags. Do NOT use the LOCALizer Reader with RFID markers other than the Health Beacons Tags. Other markers may give some response but the detection range and accuracy may be affected. Most markers at other frequencies will not be readable.

Metal Items, such as surgical tools, that block the path between the implanted Tag and LOCALizer Probe may alter the LOCALizer Reader readings. Ensure these items are not in the path of the Tag being read.

Ensure the LOCALizer Reader battery is fully charged prior to use. A back-up LOCALizer Reader is recommended in the case of instrument malfunction or battery depletion.

Do NOT immerse LOCALizer Reader in liquid.

The LOCALizer Reader is sensitive to electromagnetic interference during the operation of HF Surgical Equipment such as Electrosurgery cutting tools and instruments, and should be used non-concurrently with such equipment.

The LOCALizer Reader is a sensitive radio receiver operating at 134 kHz. Its operation may be affected by other devices operating near this frequency.

The LOCALizer Reader is intended for use only in a hospital, except near active HF Surgical Equipment and other RFID equipment or wireless battery chargers.

The LOCALizer transmits RF energy at 134 kHz and is sensitive to a receive bandwidth of 120kHz to 150kHz.

The LOCALizer Reader transmits a weak unmodulated magnetic field at 134 kHz (<200 microwatts ERP) to sense the presence of the Tag. Modulation of the field by the Tag is detected by the LOCALizer Reader. Other devices that generate electromagnetic fields in this frequency region may interfere with the ability of the LOCALizer to sense the location of the Tag. Interference may occur for example from other RFID readers, inductive chargers commonly used for cell phones or other devices, or magnetic induction proximity detectors. Sensitive devices such as other Low Frequency RFID readers may likewise be affected by the operation of the LOCALizer Reader in the same vicinity.

## ADVERSE EVENTS

The potential risks associated with implantable breast lesion localization tags, such as the RFLS include but are not limited to: bleeding upon placement, infection, and MRI interference. These adverse events do not include all adverse events that could occur with breast surgery in general but are important considerations for breast lesion localizers when used for percutaneous placement in the breast to mark a lesion intended for surgical removal.

## HOW SUPPLIED

The LOCALizer Reader with its integrated Loop Probe is provided nonsterile and is intended for reuse. The Tag Applicator and LOCALizer Surgical Probe are provided sterile and are intended for single use only. The Tag is non-pyrogenic. The RFLS is not made with natural rubber latex.

## LOCALIZER READER CONTROLS

The LOCalizer Reader contains the display and controls for the System and are located on the front face of the instrument. The LOCalizer Reader allows the user to adjust the system's settings, and produces signals in the form of a displayed distance in millimeters and an audible pitch that represents the intensity of a Probe's signal.

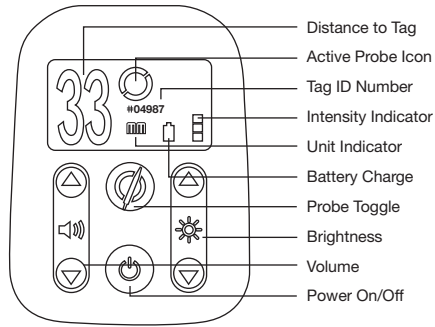

Figure 2. LOCalizer Reader Controls and Displays (described below)

Name	Control/Display	Description
Power		Turns power ON/OFF To switch ON, press the power button. The system performs a self-test before it is available for use. To switch OFF, press the ON/OFF button.
Probe Toggle		Toggles between the Loop Probe and Surgical Probe
Display - Distance Output		Displays the distance to the Tag in millimeters

Name	Control/Display	Description
Display - Tag ID		Displays the Tag ID
Display - Unit Indicator		Displays the unit of measurement as millimeters (mm)
Volume Adjustment		Increases/decreases the volume of the audible signal
Brightness Adjustment		Increases/decreases the brightness of the display
Active Probe Icon		Displays which Probe is currently active: Loop (left icon) or Surgical Probe (right icon)
Battery Indicator		Indicates current battery level The battery level decreases as the battery discharges. The symbol flashes on and off when the battery needs replacement. When the battery reaches a critical level, the device is disabled
Intensity Indicator		Indicates intensity of the signal between the Probe and the Tag The Intensity Indicator can be used alternatively to the audio tone to assess location

### Sound and Backlight

The selected sound and display light levels are stored when the instrument is turned off and recalled when it is turned on again.

When the battery is critically low, the sound level is automatically lowered to extend operating lifetime.

### TAG IMPLANTATION

Refer to the Tag Applicator Instructions for Use for details regarding Tag placement and removal methods.

## LOCALIZATION PROCEDURE

- 1 Power on the LOCalizer Reader.

The firmware version number is displayed.

There is a brief delay while the integrated loop probe is tested.

If the Surgical probe is installed, there is a corresponding delay while it is tested.

- 2 Use the up and down arrows on the brightness control to adjust the screen to the desired intensity.

- 3 Check the battery charge indicator to ensure there is adequate charge. It is highly encouraged to change the batteries before each procedure.

Batteries can be replaced following directions in the "CARE AND MAINTENANCE" section.

**NOTE:** The LOCalizer Reader may turn ON with a critically low battery, but will not continue operation normally.

- 4 Use the Loop Probe on the LOCalizer Reader to identify the general location of the Tag from the surface of the breast. The sound level and pitch increases as the LOCalizer Reader approaches the Tag. The scale shows the approximate distance to the nearest point of the Tag in millimeters. When using the Loop probe the range of the LOCalizer Reader is at least 60 mm.

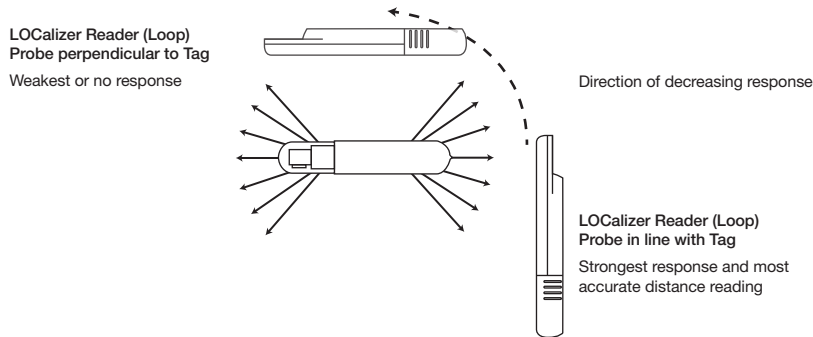

Figure 3. Assessing Tag location/position with Loop Probe using signal strength (not to scale)

**NOTE:** The sound and distance display rise to a maximum when the Tag is in line with and directly under the sensing head surface (Figure 3). Identification of the Tag location can be refined by moving the Probe until both ends of the Tag are detected.

**NOTE:** The Tag's unique identification number is displayed once the probe is close enough to the implanted Tag.

**NOTE:** If more than one Tag has been implanted, confirm the location of each prior to surgery using the Unique Tag ID number to distinguish each Tag.

- 5 Use the up and down arrows on the volume control to adjust the audio tone to the desired volume.

- 6 If excising the Tag and lesion, plan and mark the surgical area with the approximate location of the Tag.

- 7 In preparation for surgery, place the sterile LOCalizer Instrument Cover over the LOCalizer Reader per the Instrument Cover Instructions for Use.

**NOTE:** The LOCalizer Reader can be used on an un-breached breast surface in a non-sterile setting. In a sterile setting, use of the Instrument Cover is required. The Surgical Probe is only intended for sterile use.

- 8 Connect the Surgical Probe into the receptacle on the LOCalizer Reader by introducing it through the cover connector hole. When connected, the LOCalizer Reader automatically identifies the Surgical Probe as the active probe, performs a self-test and the LOCalizer Reader screen displays the Surgical Probe icon. When the Surgical Probe is attached, the range of LOCalizer Reader is at least 30 mm.

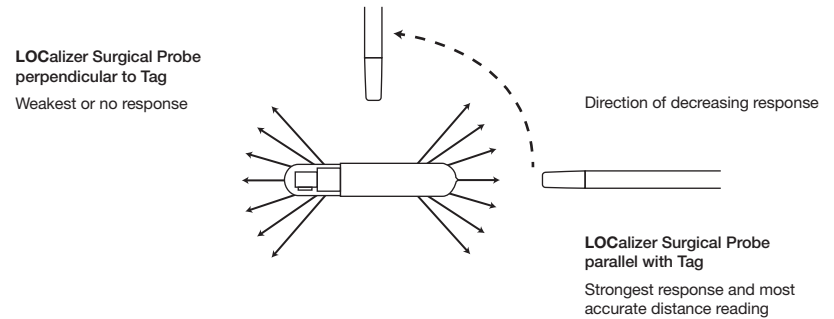

Figure 4. Assessing Tag location/position with Surgical Probe using signal strength (not to scale)

**NOTE:** Readings will vary depending on the orientation of the Tag, because the signal emitted is directional along the long axis of the Tag. The LOCalizer Reader will receive the strongest response and most accurate distance reading when the Surgical Probe is parallel with the Tag. Signal strength decreases as the Surgical Probe head moves toward perpendicular to the Tag and the distance accuracy may decrease.

**NOTE:** Tags implanted very close together have the potential to reduce distance readings slightly. The recommended minimum spacing between implanted tags is 20 mm. At this spacing, any reduction of distance to the Tag will be limited to 2 mm or less.

9 During the surgical approach, the LOCALizer Reader may be toggled between the Loop Probe and Surgical Probe by depressing the probe toggle switch. The active probe is indicated on the display.



10 Excise intended tissue with implanted Tag.

11 Confirm the Tag is present in the excised specimen using the LOCALizer Reader or imaging (ultrasound or radiography).

**NOTE:** If more than one Tag has been implanted in the tissue intended for removal, ensure the excision of all Tags.

## TROUBLESHOOTING

Little or No Tag Response	<p><b>The Tag is out of LOCALizer Reader detection range</b> Reposition the LOCALizer Loop or Surgical Probe until a signal is detected.</p> <p><b>The Tag signal is receiving interference from another Tag or device</b> Remove alternative source of signal or use alternate imaging guidance such as ultrasound or radiography to confirm Tag location.</p> <p><b>The Tag is broken</b> An alternate imaging guidance such as ultrasound or radiography should be used to ensure the entire Tag is removed with tissue removal.</p>
Tag distance reading is incorrect	<p><b>Positioning of the Reader</b> Resolution of system allows discrimination of two ends of Tag. Reposition the LOCALizer Loop or Surgical Probe and look for readings from both ends of Tag. Readings at these positions have the highest accuracy.</p>
Tag presence is indicated and incorrect	<p><b>Interference of transmitting equipment</b> If a Tag detection is indicated when no Tag is within the normal detection distance, check for other RFID readers, wireless chargers or other nearby equipment that may be transmitting in the region of 134 kHz.</p>
Tag location cannot be determined	<p><b>Readings are difficult to interpret</b> Resolution of system allows discrimination of two ends of Tag. Reposition the LOCALizer Loop or Surgical Probe and look for readings from both ends of Tag to determine Tag location.</p>
The LOCALizer Reader is unresponsive	<p><b>The LOCALizer Reader has a critically low battery</b> Replace batteries. If new batteries fail to work, the LOCALizer Reader may have suffered a fatal error. Contact your supplier for replacement of the unit.</p>

Tag ID is not displayed or display shows " #????? "	<p><b>The Tag ID is displayed only when the Loop probe is within 40mm of the Tag and the Surgical Probe is within 20mm. If within these limits, there may be an interfering signal from another RFID reader, tag or wireless charger.</b></p> <p>Check for and remove other RFID readers, tags, wireless chargers or other nearby equipment that may be transmitting in the region of 134 kHz.</p> <p>This condition may occur if multiple Tags were placed in the same operative breast and the LOCALizer Reader can't discern one Tag signal from the other. Re-position the Reader in multiple locations to identify more than one Identification number. Use the identification numbers to determine each Tag's placement.</p>
Display shows: " ? " over Probe icon	<p><b>The Selected Probe has low signal strength</b> System may continue to function, the range accuracy for tag reading may be impacted. Check environment for possible sources of interference and remove. This may occur when Probe or Reader is placed on a metal surface; moving the Probe or Reader away clears the " ? ". Check the active probe icon to ensure the correct probe is selected.</p>
Display shows:  with Probe icon.	<p><b>The Selected Probe does not pass self-test</b> For the Surgical probe, replace the Probe For the Loop probe, replace the LOCALizer Reader</p>
Battery Icon Flashing	<p><b>Low battery</b> The maximum audio volume is automatically reduced to extend remaining operational time. Replace Batteries.</p>
Display shows: 	<p><b>An Internal error has occurred</b> This is generally a permanent fatal error, and the LOCALizer Reader must be replaced. Before returning the LOCALizer Reader for service, try removing and replacing the battery. This may clear an error.</p>

## CARE AND MAINTENANCE

### Surface Care

As needed, use a damp cloth or sponge, with mild detergent if necessary. Do NOT use abrasives or solvents, as these may degrade the case. Do NOT submerge the LOCALizer Reader in liquid.

### Batteries

Periodic battery replacement is necessary for the unit to continue to operate correctly. To replace batteries, open the battery compartment by holding the textured edges and pulling firmly off the device. Install commercially available AA batteries following the battery polarity symbols on the inside of the case. Approximate battery life expectancy under normal use conditions is 8 hours. These times may be slightly reduced at high display intensity and audio volume. Use only good quality AA Alkaline cells (IEC-LR6).

## REPLACEABLE / REPAIRABLE COMPONENTS

There are no repairable components. With the exception of battery replacement, (Refer to Care and Maintenance) no modification or repair of this equipment by the user is allowed. If the LOCALizer Reader stops working or is damaged it should be replaced.

## TECHNICAL INFORMATION

### Environmental, Storage, and Transportation Conditions

LOCALizer Reader

	Operational Conditions	Temporary Storage and Transport Conditions*
Ambient Temperature	5° - 30°C (41° - 86°F)*	-20° - 50°C (-4°-122°F)
Relative Humidity	30% - 75%, non-condensing	15% - 93%, non-condensing
Atmospheric Pressure	70 kPa – 102 kPa	50kPa - 106kPa

\*For best service life of AA Alkaline Cells used in LOCALizer Reader, storage temperature should be 5° - 30°C. To avoid potential damage from cells leaking, remove battery if the LOCALizer Reader will not be used within 2 months.

Store the Tag Applicator and Surgical Probe at ambient temperature 15° to 30°C (59° to 86°F).

### Interference

This device complies with part 15 of the FCC Rules. Operation is subject to the following two conditions:

- 1 This device may not cause harmful interference.
- 2 This device must accept any interference received, including interference that may cause undesired operation.

The user is responsible to maintain FCC compliance. Any changes or modifications not expressly approved by Health Beacons could void the user's authority to operate the equipment.

Use the LOCALizer Reader only with a LOCALizer Surgical Probe and Tag.

### Electromagnetic Emissions and Immunity

This equipment has been tested and found to comply with the limits for a Class B digital device, pursuant to part 15 of the FCC Rules. These limits are designed to provide reasonable protection against harmful interference in a residential installation. This equipment generates, uses, and can radiate radio frequency energy and, if not installed and used in accordance with the instructions, may cause harmful interference to radio communications.

However, there is no guarantee that interference will not occur in a particular installation.

If this equipment does cause harmful interference to radio or television reception, which can be determined by turning the equipment off and on, the user is encouraged to try to correct the interference by one or more of the following measures:

- Reorient or relocate the receiving antenna.
- Increase the separation between the equipment and receiver.
- Consult the dealer or an experienced radio/TV technician for help.

### MRI Safety Information

The LOCALizer Reader is MR Unsafe. Keep away from magnetic resonance imaging (MRI) equipment.

























The Localizer Reader is compliant to applicable emissions and immunity standards listed below.

Standards	Description	Security Level or Limit	Criteria	Test Result
IEC 60601-1-2:2014 Product Family Standard Emissions and Immunity	Medical electrical equipment - Part 1-2: General requirements for basic safety and essential performance - Collateral standard: Electromagnetic compatibility - Requirements and tests - Edition 4	The requirements for use in the Professional healthcare facility environment were chosen by the manufacturer. See called out basic standards below	See Below	Complies
EN55011:2009 +A1:2010, FCC 15.109(a) & ICES-003	<b>Radiated Emissions:</b> At any one voltage & frequency (Per table 1)	Class B Group 1. 30MHz - 1 GHz	Limit	Complies
EN55011:2009 +A1:2010, FCC 15.107(a) & ICES-003	<b>Conducted Emissions:</b> At any one voltage & frequency (Per table 1)	NA, NA. EUT is battery operated only	Limit	NA
EN61000-3-2:2006 +A1:2009+A2:2009	<b>Power Harmonics:</b> At 230 V, 50Hz or 60 Hz (Per table 1)	NA EUT is battery operated only	Limit	NA
EN61000-3-3:2013	<b>Voltage Fluctuation:</b> At 230 V, 50Hz (Per table 1)	NA EUT is battery operated only	Limit	NA
EN61000-4-2:2009 Basic test standard	<b>Electrostatic Discharge Immunity:</b> At any one voltage & frequency (Per tables 1 and 7)	±15 kV Air Discharge ±8 kV Contact Discharge, VCP, HCP	per Annex I	Complies
EN61000-4-3:2006 + A2:2010 Basic test standard	<b>Radiated Electromagnetic Fields Immunity:</b> At any one voltage & frequency (Per tables 1 and 4)	3V/m, 80-2700 MHz at 80% 1kHz AM Modulation	per Annex I	Complies
EN61000-4-3:2006 + A2:2010 Basic test standard	<b>Radiated Electromagnetic and Proximity Fields Immunity:</b> At any one voltage & frequency (Per tables 4 and 9)	RF wireless communication fields on Spot Frequencies from Table 9 at 50%, Square wave Modulation 9 to 28 V/w	per Annex I	Complies
EN61000-4-4:2012 Basic test standard	<b>Electrical Fast Transient/Burst Immunity:</b> 100kHz at any one voltage & frequency (Per table 1)	NA on AC or DC Mains ±1 kV SIP/SOP EUT is battery operated only	per Annex I	Complies
EN61000-4-5:2006 Basic test standard	<b>Surge Immunity:</b> At any one voltage & frequency (Per table 1)	NA CM Line-Gnd NA, DM Line-Line NA SIP/SOP Ports are not connected directly to outdoor cables	NA	NA
EN61000-4-6:2009 Basic test standard	<b>Conducted Immunity:</b> At any one voltage & frequency (Per table 7)	3V rms, 0.15 - 80 MHz 6V rms, on ISM bands on SIP/SOP port only	per Annex I	Complies
EN61000-4-8:2010 Basic test standard	<b>Power Frequency Magnetic Field Immunity:</b> At any one voltage at 50 or 60 Hz (Per table 1)	30A/m @ 50Hz or 60Hz 3 orthogonal orientations	per Annex I	Complies
EN61000-4-11:2004 Basic test standard	<b>Voltage Dips and Voltage Interruptions:</b> At min & max rated input voltage at any rated power frequency (Per table 1)	NA EUT is battery operated only NA NA NA NA	NA	NA

## SYMBOLS

The following symbols may be found on the product labeling for the RFID Localization System:

Symbol	Description
	Use by Date
YYYY-MM-DD	Expiration date is represented by the following: YYYY represents the year MM represents the month DD represents the day
	Manufacture Date
	Manufacturer
	Follow instructions for use <a href="http://www.hologic.com/package-inserts">www.hologic.com/package-inserts</a>
	Do NOT use if package is damaged
	Do NOT resterilize
	Single use only
<b>Rx ONLY</b>	U.S. Federal law restricts this device to sale by or on the order of a physician
	Sterilized using Ethylene Oxide (Tag Applicator)
	Sterilized using irradiation (Probe)
	Quantity

Symbol	Description
	Catalog Number
	Batch Code
	Serial Number
	Caution
	Device is non-sterile
	Type B Equipment
	Temperature limitation
	Humidity limitation
	Do NOT dispose of the Localizer Reader by placing into trash receptacles.
	Keep dry
	Self test in process
	Call for Service
	The Localizer Reader is MR Unsafe. Keep away from magnetic resonance imaging (MRI) equipment.

## DISPOSAL OF EQUIPMENT

After following the cleaning recommendations above, and there are no biohazard risks involved, dispose of the Localizer Reader at the end of the Localizer Reader's useable life per Waste of Electrical and Electronic Equipment (WEEE) directive [Directive 2002/96/EC]. Dispose of Tag Applicator, Surgical Probe, and Instrument Cover per the device Instructions for Use.