

# Operator's Manual



## ATEC<sup>®</sup> Breast Biopsy and Excision System

### *Sapphire Unit*

**HOLOGIC<sup>®</sup>**



Hologic Ltd.  
Heron House Oaks Business Park, Crewe Road  
Wythenshawe, Manchester. M23 9HZ, UK

**CE** 0086

# HOLOGIC®

© 2013-2015 Hologic inc. All rights reserved. Hologic, ATEC Eviva, Multicare, and StereoLoc are trademarks and/or registered trademarks of Hologic, Inc. and/or its subsidiaries, in the United states and/or other countries. All other trademarks, registered trademarks, and product names used within this document are the property of their respective owners.

MAN-03327-001 Rev. 005

# Congratulations!

---

Thank you for purchasing the ATEC Sapphire Breast Biopsy and Excision System: Sapphire unit.

## Table of Contents

---

ATEC® Breast Biopsy and Excision System: Sapphire.....	4
Warnings and Precautions .....	4
Introduction.....	5
Indications .....	5
Contraindications.....	5
Components .....	6
Product Nomenclature and Disposable Product Selection.....	7
Console Controls and Functions .....	9
Console User Interface.....	9
ATEC Breast Biopsy and Excision System: Sapphire Unit Set Up.....	10
ATEC Breast Biopsy and Excision System: Sapphire Unit Check Out.....	14
ATEC Breast Biopsy and Excision System: Sapphire Unit Operating Instructions.....	14
Performing a Biopsy Using MRI Guidance .....	14
Performing a Biopsy Using Stereotactic Guidance.....	14
Performing a Biopsy Using Ultrasound Guidance .....	15
ATEC Handpiece Operating Instructions.....	15
Troubleshooting.....	16
Warranty.....	18
Service and Maintenance.....	19
Cleaning Instructions .....	22
Specifications .....	23
Electromagnetic Emissions .....	25
Symbols.....	28
Important Contact Information: U.S. Customers and Canadian Customers.....	30
Important Contact Information: For all other International Customers.....	31
Appendix A: Stereotactic Adapter .....	32
Cleaning Instructions .....	33

# ATEC® Breast Biopsy and Excision System: Sapphire

---

Please read all contents of the Operator's Manual for your ATEC® Breast Biopsy and Excision System: Sapphire unit prior to installation and operation. Follow all warnings and instructions as stated in this manual. Keep this manual available during procedures. Physicians should inform patients about all potential risks and adverse events discussed in this manual with respect to the use of the ATEC Breast Biopsy and Excision System: Sapphire unit.

As used below, the term "Hologic®" means Hologic, Inc., a Delaware corporation. Also, the term "ATEC Breast Biopsy and Excision System: Sapphire unit" means the ATEC Sapphire console unit and all available ATEC Breast Biopsy and Excision System components, as more fully described in the components section below (unless the context dictates otherwise).

## Warnings and Precautions

---

### Safety and Electrical

1. Should any object or liquid fall into the ATEC Sapphire console, unplug the console and have it checked by qualified personnel before operating it any further.
2. Unplug the console from the electrical outlet if it is not to be used for several days or an extended period of time.
3. To prevent fire or shock hazard, do not expose the console to rain or moisture.
4. To prevent shock hazard, do not use the console's polarized plug with a receptacle unless the blades can be fully inserted to prevent blade exposure.
5. Do not use the console's polarized plug with an extension cord.
6. **DANGER:** There is a small risk of explosion if the ATEC Sapphire unit is used in the presence of flammable anesthetics or other explosive gases.
7. Grounding reliability can only be achieved when the console is connected to an equivalent receptacle marked "Hospital Grade."
8. The console should not touch other electrical equipment during use.
9. The console can radiate radio frequency energy and, if not installed and used in accordance with the instructions, may cause harmful interference to other devices in the vicinity. However, there is no guarantee that interference will not occur in a particular installation. If the console does cause harmful interference to other devices, which can be determined by turning the console off and on, the user is encouraged to try to correct the interference by one or more of the following measures:
  - a. Reorient or relocate the receiving device.
  - b. Increase the separation between the equipment.
  - c. Connect the console to an outlet on a circuit different from that which the other device(s) are connected.
  - d. Consult Hologic for technical help.
10. Damage to the power cord may cause a fire or shock hazard. When unplugging the power cord, please hold by the plug and remove it carefully. Do not damage or modify the console power cord.
11. Do not attempt to use any console that could present a shock hazard. Immediately contact Hologic or your distributor.
12. Do not place the console on an unstable surface. The console may fall, causing serious injury and damage to the appliance. Quick stops, excessive force and uneven surfaces may cause the console to overturn.

### Maintenance and Storage

1. Allow adequate air circulation around the console to prevent internal heat build-up. Do not place the console within 1ft. (.30m) of any obstructive surface.
2. Do not install the console in a location near heat sources such as radiators or air ducts, or in a place subject to direct sunlight, excessive dust, mechanical vibration or shock.
3. When the console is not being used, turn off all power switches and place the console in a location where it will not be damaged.
4. To keep the console looking new, periodically clean it with a soft cloth. Stubborn stains may be removed with a cloth lightly dampened with a mild detergent solution. Never use strong solvents or abrasive cleansers since these will damage the console casing. The console should only be cleaned after the power cord is disconnected from the power outlet.
5. The ATEC Sapphire unit console should only be opened or serviced by Hologic or qualified personnel who have been trained and certified by Hologic.

6. Some ATEC Sapphire unit consoles may include settings specific to higher altitudes. Please contact Customer Support or your Distributor if you move your console to a significantly different physical address. Do not operate the ATEC Sapphire unit console at altitudes higher than 3,000 meters (9,842 feet).
7. If you are a Hologic customer in the U.S. or in Canada, please consult your Hologic Sales Representative or contact Customer Support if you cannot correct a problem using this Operator's Manual. All other international customers, please contact your distributor directly with questions, comments and/or technical service issues.

## Operation

1. THE COMPONENTS OF THE ATEC SAPPHIRE UNIT ARE FOR USE ONLY BY QUALIFIED MEDICAL PERSONNEL TRAINED IN THEIR USE AND APPLICATION. Qualified medical personnel should perform a test of the ATEC Breast Biopsy and Excision System: Sapphire unit prior to each procedure or prior to each time a new single patient use disposable is attached to the console.

## Compatibility

1. The ATEC Sapphire unit console is NOT intended for use inside the MRI suite. The ATEC Sapphire unit console must reside outside of the MRI suite.
2. Use only disposables that are manufactured by Hologic. Use of any other disposables may result in damage to the console and unintended injury to the patient or unacceptable clinical results and shall void any warranty provided by Hologic.
3. Only Hologic-approved accessory equipment and components shall be used with the ATEC Sapphire unit. Use of the ATEC Sapphire unit with unauthorized accessory equipment and components shall void any warranty provided by Hologic.
4. All disposables associated with the ATEC Sapphire unit are intended for single patient use and are not intended for resterilization and subsequent reuse. Dispose of all single patient use instruments after opening.

## Introduction

---

This manual is written for medical personnel who will be responsible for operating the ATEC Sapphire unit. It is extremely important that the operator read and thoroughly understand the contents of this manual, be trained by a qualified applications specialist, and follow the instructions contained herein for reliable, safe and efficient operation of the product.

**Rx** ONLY (U.S.) Federal law restricts this device to sale by or on the order of a physician pursuant to 21 CFR 801.109(b)(1).

## ATEC Users in the United States and Canada

All users of the ATEC Sapphire unit in the United States and Canada should contact their Hologic Sales Representative or the Hologic Customer Service Department for questions, comments, and/or technical service issues.

## Other International ATEC Users

All other international users of the ATEC Sapphire unit should contact their distributor directly with questions, comments, and/or technical service issues.

## Indications

The ATEC Breast Biopsy and Excision System is indicated to provide breast tissue samples for diagnostic sampling of breast abnormalities. The ATEC Breast Biopsy and Excision System is intended to provide breast tissue for histologic examination with partial or complete removal of the imaged abnormality. The extent of histologic abnormality cannot be reliably determined from its mammographic appearance. Therefore, the extent of removal of the imaged evidence of an abnormality does not predict the extent of removal of histologic abnormality, e.g., malignancy. When the sampled abnormality is not histologically benign, it is essential that the tissue margins be examined for completeness of removal using standard surgical procedure.

## Contraindications

1. The ATEC Breast Biopsy and Excision System is for diagnostic purposes only and is not intended for therapeutic applications.
2. The ATEC Breast Biopsy and Excision System is contraindicated for those patients who, based on the physician's judgement, may be at increased risk or develop complications associated with core removal or biopsy. Patients

receiving anticoagulant therapy or who may have bleeding disorders may be considered at increased risk of procedural complications.

## Notes on the MRI Environment

1. The ATEC Sapphire unit may be used to perform biopsies under ultrasound (U/S), stereotactic (STX) or MRI guidance.
2. The ATEC Sapphire unit console is NOT intended for use inside the MRI suite. The ATEC Sapphire unit console must reside outside of the MRI suite.
3. The ATEC MRI footswitch, ATEC MRI handpiece and ATEC MRI Introducer Localization System (ILS) are specifically designed for use in the MRI suite. Items which may be brought into the MRI suite will be marked with the “MRI Conditional” symbol.
4. Hologic offers a variety of disposable handpiece configurations. However, when performing MRI-guided breast biopsy procedures, an ATEC MRI handpiece MUST be used. ATEC handpieces designed for use with MRI guidance are compatible with the **red** receptacle marked “MRI” on the console. The ATEC MRI Introducer Localization System (ILS) is available for localizing the area targeted for biopsy.
5. An overview of the products suited for MRI, Stereotactic (STX) and Ultrasound (U/S) guided biopsy procedures is included in the Components section.

## Notes on the Stereotactic and Ultrasound Environment

1. ATEC handpieces designed for use with stereotactic (STX) and ultrasound (U/S) guidance are compatible with the **red** receptacle marked “US/STX” on the console.
2. The particular handpiece selected for use with ultrasound (U/S) and stereotactic (STX) guidance depends on user preference and the type of stereotactic (STX) system being used. Please refer to the Disposable Product Selection section of this manual for additional guidance.

## Components

**TABLE 1: CAPITAL EQUIPMENT (MULTIPLE PATIENT USE)**

	Stereotactic Guided Biopsy Procedures	Ultrasound Guided Biopsy Procedures	MRI Guided Biopsy Procedures
ATEC Breast Biopsy and Excision System: Sapphire unit	•	•	•
ATEC Footswitch	•	•	•
ATEC Power Cord	•	•	•
ATEC Vacuum Line Assembly	•	•	•
ATEC Stereotactic Adapter	•	N/A	N/A
Eviva Stereotactic Adapter	•	N/A	N/A

**TABLE 2: DISPOSABLE COMPONENTS (SINGLE PATIENT USE)**

	Stereotactic Guided Biopsy Procedures	Ultrasound Guided Biopsy Procedures	MRI Guided Biopsy Procedures
ATEC Handpiece	•	•	N/A
ATEC MRI Handpiece	N/A	N/A	•
ATEC Introducer Localization System (ILS)	N/A	N/A	•
Eviva Biopsy Device	•	N/A	N/A
Needle Guide (ATEC and Eviva®)	•	N/A	N/A
ATEC Canister with Lid	•	•	•
ATEC Tissue Filter	optional	optional	optional
ATEC Remote Tissue Filter Adapter (RTFA)	See Note 1	N/A	N/A

Note 1: To be used with Hologic Stereoloc® II upright stereotactic system and Siemens stereotactic systems. Optional for all other stereotactic systems.

# Product Nomenclature and Disposable Product Selection

Hologic offers a variety of ATEC handpiece or Eviva biopsy device configurations to be used under stereotactic, ultrasound and MRI guidance. The specific handpiece or biopsy device to be selected depends on user preference and the type of imaging equipment being used as indicated in Table 4 and Table 5. Please refer to the Hologic website at [www.hologic.com](http://www.hologic.com) for an updated list of disposable product offerings.

ATEC handpiece and Eviva biopsy device catalog numbers use the following number nomenclature:

**TABLE 3: NOMENCLATURE OF CATALOG NUMBERS: ATEC 09 12-20**

Device Type	Cutting Cannula Needle Gauge	Needle length (cm)	Aperture Size (mm)	Suffix (if any)
ATEC	09: 9 guage	09: 9 cm long	12: 12 mm aperture	MR: MR dedicated handpiece
EVIVA	12: 12 guage	12: 12 cm long 13: 13 cm long 10: 10 cm long	20: 20 mm aperture	T: Petite

**TABLE 4: EVIVA BIOPSY DEVICE COMPATIBILITY**

		Biopsy Device				Needle Guide				Stereotactic Adapter Kit											
Modality	Equipment	Eviva 0913-20	Eviva 1213-20	Eviva 0913-12	Eviva 0913-12T	Eviva 0910-20	Eviva 1210-20	Eviva 0910-12	Eviva 0910-12T	Eviva NG09L	Eviva NG12L	Eviva NG09R	Eviva NG12R	Eviva STX KIT 13CM	Eviva STX KIT MTEST	Eviva STX KIT SLOC	Eviva STX KIT GEL-V	Eviva STX KIT GEVER	Eviva STX KIT GELAT	Eviva STX KIT AFFIRM	Eviva STX KIT OPDIMA
		Stereotactic (STX)	Hologic MultiCare® Platinum	•	•	•	•			•		•	•			•					
Hologic Stereloc® II Upright						•	•	•	•	•	•					•					
Hologic Affirm™	•		•	•	•	•	•	•	•	•	•									•	
Siemens® (Fischer) Mammotest	•		•	•	•					•	•					•					
GE Senographe DS® and Senographe® Essential Lateral Arm	•		•	•	•							•	•				•		•		
GE Senographe DS® and Senographe® Essential Vertical Approach						•	•	•	•			•	•				•	•			
Siemens® Opdima						•	•	•	•			•	•								•

Note: Product Availability may vary by Country.

Note: For other Imaging Modalities and Equipment, contact your Hologic Representative or Distributor.

**TABLE 5: ATEC HANDPIECE COMPATIBILITY**

		Handpiece								Stereotactic Adapter Kit				Ancillary Devices											
Modality	Equipment	ATEC 0909-12	ATEC 0909-20	ATEC 0912-12	ATEC 0912-20	ATEC 0914-20	ATEC 1209-20	ATEC 1212-20	ATEC 0914-20MR	ATEC 0914-12MR	ATEC STX-1	ATEC STX-2	ATEC STX-Fischer	ATEC STX-2F	ATEC NG09	ATEC NG09F	ATEC NG12	ATEC NG12F	ATEC NG09A1	ATEC NG09A2	ILS 0914-20	ILS 0914-12	ILS 0914-20-OB	ILS 0914-12-OB	ATEC RTFA
Stereotactic (STX)	Hologic MultiCare® Platinum			•	•			•			•	•			•		•								•
	Hologic Stereloc® II			•	•			•				•			•		•								•*
	Hologic Affirm™	•	•	•	•	•	•	•				•			•		•								•*
	Siemens® (Fischer) Mammostest	•	•				•						•	•		•		•							•
	Siemens® (Fischer) Mammostest Lateral Approach					•						•				•									•
	Siemens® Opdima		•	•	•			•				•				•		•							•*
	GE Senographe DS® and Senographe® Essential Vertical Approach			•	•			•								•		•							•*
	GE Senographe DS® and Senographe® Essential Lateral Arm Approach					•						•				•									•*
	Instrumentarium® Delta 32					•						•				•									•
U/S	Ultrasound Procedures		•		•			•																	•
MRI	Aurora MRI System								•	•									•	•	•	•	•	•	•
	Other MRI Systems								•	•					Included in ILS Kit						•	•	•	•	

Note: Product Availability may vary by Country.

Note: For other Imaging Modalities and Equipment, contact your Hologic Representative or Distributor.

\* Preferred ancillary equipment



# Console Controls and Functions

The console user interface panels include controls that enable the user to operate the ATEC system and indicator lights that provide additional information about system status. A detailed description of each component on the user interface can be found below.









LEFT USER INTERFACE



RIGHT USER INTERFACE



## Console User Interface

1. **Power Switch** - Turns power to the console on and off:
  - On** = Illuminated **green** and “ I ”
  - Off** = Not Illuminated and “ O ”
2.  **“Setup”** Button - This push button control allows for the self-priming of the system with saline. When placed in “Setup” mode, the “Saline PV” (Pinch Valve) is opened and the vacuum is turned on, allowing insertion of the silicone tubing section of the handpiece saline line.
3.  **“Test”** Button - This push button control activates the handpiece through one test cycle. The system will return to “Biopsy” mode upon successful completion of one test cycle.
4.  **“Biopsy”** Button - When placed in “Biopsy” mode, the handpiece is ready for tissue acquisition. Footswitch input begins biopsy cycling.
5.  **“Lavage”** Button - When placed in “Lavage” mode, the “Saline PV” is opened and vacuum is turned on to irrigate and aspirate the biopsy cavity.
6.  **“Manual Aspiration”** Button - When placed in “Manual Aspiration” mode, the “Saline PV” is closed and the inner cutting cannula is retracted. In this mode, the user can vacuum the biopsy cavity by depressing the footswitch.
7.  **“Retest Handpiece”** Indicator - Does not illuminate under normal conditions. Flashes **red** when “Test” or “Biopsy” mode is not completed due to pressure failure. Refer to the Troubleshooting section for suggested steps to diagnose and correct a potential problem.
8.  **“Return to Setup”** Indicator - Does not illuminate under normal conditions. Flashes **red** when “Test” mode is not completed due to vacuum failure. Refer to the Troubleshooting section for suggested steps to diagnose and correct a potential problem.
9.  **“Vacuum Ready”** Indicator - Illuminates solid **green** when the console has achieved full vacuum. Flashes **green** when full vacuum is not achieved within the specified timeframe. If this indicator flashes, refer to the Troubleshooting section for suggested steps to diagnose and correct a potential problem. The footswitch will not enable the handpiece to function unless this indicator is illuminated solid **green**.
10. **Vacuum Line Assembly** - This is clear tubing that is permanently attached to the console at one end. The other end has a blue connector that will attach to the Suction Canister lid at the port labeled “VACUUM”.

11. **Red “MRI” Handpiece Receptacle** - Attachment site for the MRI handpiece fitting with the **red** sleeve.
12. **Black Handpiece Receptacle** - Attachment site for the handpiece fitting with the black sleeve.
13. **Red “US/STX” Handpiece Receptacle** - Attachment site for the US/STX handpiece fitting with the **red** sleeve.
14. **“Saline PV” (Pinch Valve)** - Attachment site for the silicone tubing section of the handpiece saline line. Controls the flow of the saline to the handpiece.

## **ATEC Breast Biopsy and Excision System: Sapphire Unit Set Up**

---

This section provides information on how to make all necessary connections to set up the ATEC Sapphire unit.

The following connections will be explained:

1. ATEC Power Cord and Footswitch
2. ATEC Footswitch Connection
3. ATEC Vacuum Line Assembly
4. ATEC Handpiece or Eviva Biopsy Device Connection

**NOTE:** Refer to Eviva IFU for Eviva biopsy device operating instructions and warnings.

### **ATEC Power Cord Connection and Circuit Breaker**

**CAUTION:** Grounding reliability can only be achieved when this equipment is connected to a receptacle marked “Hospital Grade”. Check grounding continuity regularly.

**WARNING:** The ATEC Sapphire unit console was designed to be used with the ATEC Hospital Grade Power Cord provided with the console. DO NOT use a different power cord with the ATEC Sapphire unit. Using a different power cord may create an electrical and fire hazard. DO NOT, under any circumstances, remove the ground wire or ground plug from any power plug. DO NOT use an extension cord with this equipment. An adapter may be necessary depending on the outlet used.

**WARNING:** Ensure that the power cord is in good condition. A damaged power cord can be an electrical shock hazard. When unplugging the unit, always grasp the plug at the insertion point and pull gently. NEVER pull on the cord to unplug the unit.

FIGURE 1: ATEC CONSOLE EXTERNAL COMPONENTS

LEFT SIDE

RIGHT SIDE

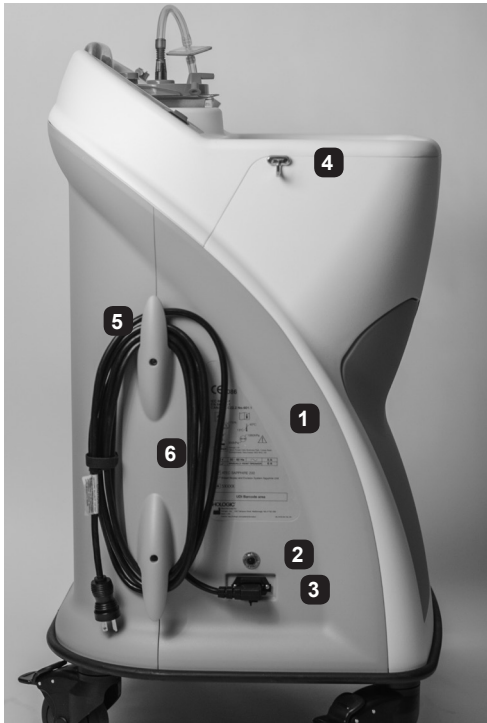

1. **Label** - Consult this label if you need any information on the electrical ratings of the ATEC Sapphire unit. This label also contains the serial number of your ATEC Sapphire unit.
2. **Circuit Breaker** - Part of the AC Inlet. If the circuit breaker has been tripped, the black button will not be flush and a white dot will be visible. To reset, turn the unit off and allow for a one-minute “cool down” period before depressing the black button to restart the unit.
3. **AC Inlet** - Attachment site for the “ATEC Hospital Grade” Power Cord plug.
4. **Instructions Placard Hook** - Attachment site for the instructions placard.
5. **ATEC Hospital Grade Power Cord** - Connect the ATEC Power Cord into the power cord receptacle on the side panel AC inlet on the left side of the console.
6. **ATEC Power Cord Management Plate** - Cord should be wound clockwise (cw) around the Cord management plate.
7. **ATEC Footswitch** - Provided by Hologic. Attaches to the right side of the console. Activates handpiece or biopsy device.
8. **ATEC Footswitch Cord Management Plate** - Cord should be wound counter-clockwise (ccw) around the cord mangement plate..
9. **Saline Bag Hook** - Attachment site for saline bag (250cc recommended).
10. **Casters** - All four casters allow for a 360-degree swivel capability and have locking brakes to hold the unit in place.

## ATEC Footswitch Connection

The ATEC footswitch is provided by Hologic and should be attached to the right side of the console upon delivery. Verify footswitch connections prior to use per the Field Replaceable Items Section of this manual.

## ATEC Vacuum Line Assembly

The system will generate vacuum when the proper modes are selected.

The vacuum connections require that you use a Hologic ATEC canister. (Refer to Figure 2)

1. Assemble the suction canister, as shown in **Figure 2**, and place the canister in the canister holder on the console.
2. Ensure that the lid and large port cap are secure and sealed to avoid vacuum leaks.
3. Plug the vacuum line assembly on the console into the top port labeled "VACUUM"  on the suction canister lid.

**FIGURE 2: ATEC CANISTER**

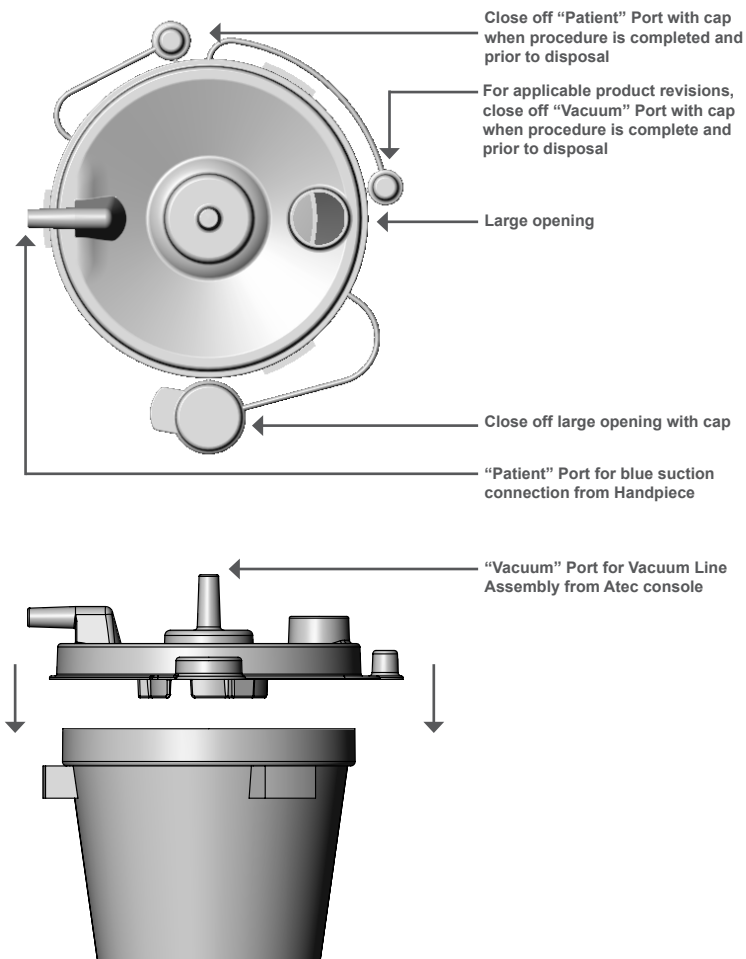

**NOTE:** The ATEC Canister is a single use product with a recommended maximum volume of 400cc.

## ATEC Handpiece and Eviva Biopsy Device Connections

1. Peel open the saline bag, remove the cap and place the bag on the saline bag hook on the right side of the console.
2. Peel open the sterile pack of the disposable handpiece and place the tray on the top of the console.

**CAUTION:** Leave the protective sheath on handpiece tip.

3. Remove the terminal ends of the four lines from the handpiece tray (refer to figure 3).
  - a. Install the spike to the saline bag and insert the silicone section of the handpiece tubing into the pinch valve labeled "Saline PV".
  - b. Plug the **red** banded line into the receptacle on the console with the red ring.
    1. Eviva Biopsy Devices designed for use with stereotactic (STX) guidance are compatible with the **red** receptacle marked "US/STX" on the console.
    2. ATEC handpieces designed for use with the stereotactic (STX) and ultrasound (U/S) guidance are compatible with the **red** receptacle marked "US/STX" on the console.
    3. ATEC handpieces designed for use with MRI guidance are compatible with the **red** receptacle marked "MRI" on the console.
  - c. Plug the **black** banded line into the receptacle on the console with the **black** ring.
  - d. Attach the **blue** suction fitting to the horizontal side port marked "PATIENT" on the suction canister lid

**FIGURE 3: VACUUM AND HANDPIECE ASSEMBLY AND CONNECTIONS**



# ATEC Breast Biopsy and Excision System: Sapphire Unit Check Out

1. Power up the system by switching the **green** “Power” switch on the console to the “I” position. This switch will illuminate **green** when “on”.
2. The power up or default mode is “Biopsy”.
3. Select the Setup mode. “Setup” mode will prime the system and generate vacuum.

When the console is in “Setup” Mode, the “Vacuum Ready” light will illuminate solid **green** when ample vacuum is achieved (see **Figure 4**). If ample vacuum is not achieved, the “Vacuum Ready” light will flash **green** to alert the user to a possible problem. If the “Vacuum Ready” light flashes, refer to the **Troubleshooting** section of this manual for suggested steps to diagnose and correct a potential problem.

4. Verify the silicone section of the saline tubing line into the pinch valve labeled “Saline PV” as shown in **Figure 5**.
5. Visually verify the flow of saline into the aperture (mouth) and tissue filter canister of the ATEC handpiece.

**CAUTION:** Do not remove the protective sheath from the handpiece tip.

6. The “Vacuum Ready” indicator will illuminate solid **green** to verify that vacuum has been attained.
7. Select the “Test” mode.
8. The ATEC handpiece will complete one test cycle. If the “Retest HP” or “Return to Set up” indicator begins to flash **red** refer to the **Troubleshooting** section of this manual for suggested steps to diagnose and correct a potential problem.
9. Upon completion of a successful test cycle, the ATEC handpiece will return to “Biopsy” and is ready for tissue acquisition.

**FIGURE 4: ATEC BREAST BIOPSY AND EXCISION SYSTEM: SAPPHIRE UNIT CHECK OUT**



**FIGURE 5: SALINE PINCH VALVE CONNECTION**



# ATEC Breast Biopsy and Excision System: Sapphire Unit Operating Instructions

## Using the System in MRI, Stereotactic or Ultrasound Guidance

1. When the console is in “Biopsy” mode, depressing the footswitch will activate the vacuum and operation of the ATEC handpiece. Removing your foot from the footswitch will inactivate or stop the device after completing the current cycle.
2. When the console is in “Lavage” mode, the vacuum system is activated and will pull saline through the system. Depressing the footswitch does not control the flow of saline in this mode.
3. When the console is in “Manual Aspiration” mode, depressing the footswitch allows the user to independently control aspiration without taking a tissue sample. This function may be used to vacuum or irrigate the biopsy cavity. Saline does not flow on this mode.

## Performing a Biopsy Using MRI Guidance

When performing a biopsy under MRI guidance, an ATEC ILS kit is required in addition to the ATEC handpiece, as stated in table 4. Please refer to the ATEC ILS (MRI) IFU for operating instructions.

## Performing a Biopsy Using Stereotactic Guidance

When performing a biopsy under stereotactic guidance, a stereotactic adapter is required to hold the ATEC handpiece or Eviva biopsy device in place on a stereotactic system.

Hologic offers multiple stereotactic adapter models for the ATEC handpiece. For additional instructions, please refer to the ATEC stereotactic adapter instructions (IFU) and Appendix A.

Additional stereotactic adapter models are offered for the Eviva biopsy device. For additional instructions on using the Eviva devices, please refer to the Eviva Instructions for Use (IFU).

# Performing a Biopsy Using Ultrasound Guidance

There is no additional equipment needed to perform a biopsy.

**NOTE:** For other Imaging Modalities and Equipment, contact your Hologic Representative or Distributor.

## ATEC Handpiece Operating Instructions

1. To administer preferred anesthetic, attach a 10cc needleless syringe of anesthetic to Y-valve. To initiate automatic delivery of anesthetic, inject 1-2cc of anesthetic manually.
2. To begin tissue acquisition, press down on the footswitch and hold in the depressed position throughout the biopsy procedure. Removing your foot from the footswitch will inactivate or stop the device after completing the current cycle.
3. To rotate the aperture on the outer cannula of the handpiece, rotate the handpiece from one position to the next desired position as the console beeps until the desired target area has been sampled. The clock dial on the handpiece indicates the position of the aperture. The arrow head printed on the handpiece indicates the 12 o'clock position.
4. To irrigate and aspirate the cavity and clear the handpiece tissue, select "Lavage" mode. It is not necessary to depress the footswitch.
5. To vacuum the cavity in "Lavage" mode, disconnect the luer lock of Y-valve to open the saline line to the vent to atmosphere resulting in constant aspiration of the biopsy cavity.
6. Alternately, to vacuum the cavity, select "Manual Aspiration" mode and depress the footswitch. Removing your foot from the footswitch will inactivate or stop vacuum to the handpiece.
7. Disconnect the filter chamber to remove the tissue cores from the tissue filter.
8. To deploy a biopsy site marker, refer to the Hologic marker of choice Instructions for Use (IFU).  
(If using an ATEC Stereotactic Adapter)
9. Place the console in "Biopsy" mode in order to close the aperture prior to removal of the handpiece from the biopsy cavity.
10. Slide the adapter with handpiece back.
11. Unlock the retaining clamp and remove the handpiece from the adapter.

**FIGURE 10: ATEC HANDPIECE**

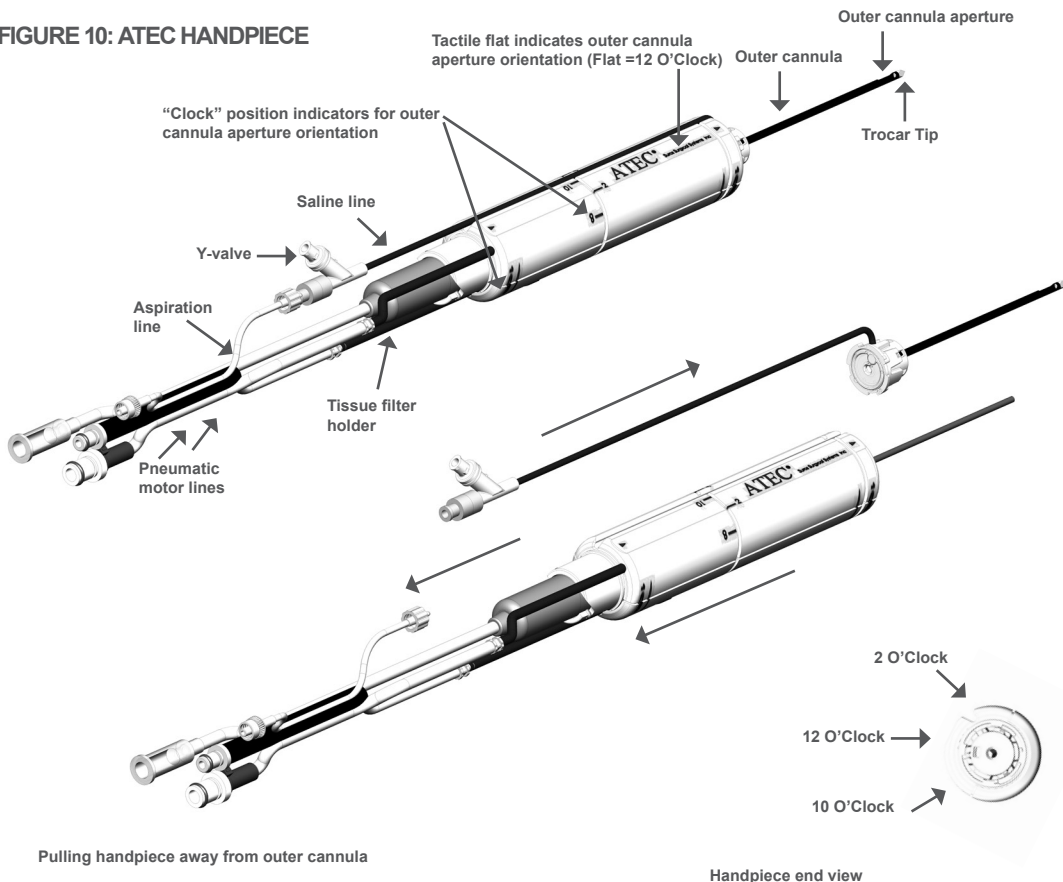

Pulling handpiece away from outer cannula

Handpiece end view

# Troubleshooting

This section provides assistance with possible problems operating the ATEC Sapphire unit. Please consult the following information before contacting Hologic or your distributor to make sure the problem is not a result of misinterpreting the operation of the system. If you are a Hologic customer in the U.S. or Canada, please consult your Hologic Sales Representative or contact Hologic Customer Support if you cannot correct a problem using this Operator's Manual. All other international customers, please contact your distributor directly with questions and/or comments.

## POSSIBLE PROBLEMS ENCOUNTERED DURING SET UP OF THE ATEC SAPPHIRE SYSTEM WITH THE ATEC HANDPIECE

Problem	Possible Cause	Possible Remedy
Console will not turn on Or No Power: Power Switch is not Illuminated	<ol style="list-style-type: none"> <li>1. Power cord is not plugged in at the console and/or wall outlet.</li> <li>2. Circuit breaker is tripped. White dot can be seen on reset pin.</li> </ol>	<ol style="list-style-type: none"> <li>1. Check power cord for proper engagement to console and wall outlet.</li> <li>2. Reset breaker (see Figure 1)</li> </ol>
"Vacuum Ready" indicator flashes or will not illuminate in "Setup" mode Or "Return to Setup" indicator illuminates in "Test" mode	<ol style="list-style-type: none"> <li>1. Protective sheath is not on tip of handpiece cannula fully.</li> <li>2. Suction canister lid is not seated onto canister.</li> <li>3. Suction canister is cracked.</li> <li>4. Large port on suction canister lid not capped with large plug.</li> <li>5. Handpiece suction fitting is not connected to the suction canister lid.</li> <li>6. Handpiece suction fitting is not connected to the correct port on suction canister lid.</li> <li>7. Console vacuum line is not connected to the suction canister.</li> <li>8. Spike on handpiece tubing is not inserted into saline bag.</li> <li>9. Saline Y-Valve is disconnected.</li> <li>10. Defective handpiece.</li> </ol>	<ol style="list-style-type: none"> <li>1. Re-install protective sheath.</li> <li>2. Properly seat lid on canister.</li> <li>3. Replace with new suction canister.</li> <li>4. Cap large port with large plug.</li> <li>5. Connect suction fitting to canister.</li> <li>6. Connect handpiece suction fitting to the horizontal port marked "patient" on the suction canister lid.</li> <li>7. Connect the console vacuum line to the port marked "vacuum" on the suction canister lid.</li> <li>8. Install spike into saline bag.</li> <li>9. Reconnect Y-Valve.</li> <li>10. Retain handpiece, record Lot Number, and contact Hologic Customer Support or your distributor.</li> </ol>
"Retest Handpiece" indicator illuminates in "Test" mode	<ol style="list-style-type: none"> <li>1. Handpiece fittings plugged into console incorrectly.</li> <li>2. Defective handpiece.</li> </ol>	<ol style="list-style-type: none"> <li>1. Connect red banded line on the handpiece into the appropriate "MRI" or "STX/US" red receptacle on the console, and black banded line to the black receptacle.</li> <li>2. Retain handpiece, record Lot Number, and contact Hologic Customer Support or your distributor.</li> </ol>



Problem	Possible Cause	Possible Remedy
<p>Poor quality biopsy cores or no cores</p>	<ol style="list-style-type: none"> <li>1. Reduced or no vacuum at tip of handpiece cannula.               <ol style="list-style-type: none"> <li>a. Suction Canister lid is not fully seated onto canister.</li> <li>b. Suction canister is cracked.</li> <li>c. Large port on suction canister lid is not capped with large plug.</li> <li>d. Handpiece suction fitting is not connected to the suction canister lid.</li> <li>e. Handpiece suction fitting is not connected to the correct port on suction canister lid.</li> </ol> </li> <li>2. Inner cutting canula is not sharp.</li> <li>3. Tissue filter is occluded by blood.</li> <li>4. Saline line is not inserted into pinch valve.</li> <li>5. Too much compression on the breast during a stereotactic procedure.</li> </ol>	<ol style="list-style-type: none"> <li>1. Restore vacuum at tip of the handpiece cannula through the following steps:               <ol style="list-style-type: none"> <li>a. Properly seat lid on canister.</li> <li>b. Replace suction canister.</li> <li>c. Close off large port on canister lid with large plug.</li> <li>d. Connect suction fitting to patient port marked "patient" on the lid.</li> <li>e. Connect handpiece (blue) suction fitting to patient port marked "patient" on the lid, and connect console vacuum line assembly to the vacuum port marked "vacuum" on the lid.</li> </ol> </li> <li>2. Replace with a new handpiece.</li> <li>3. Replace with a new handpiece.</li> <li>4. Install saline line into pinch valve.</li> <li>5. Reduce compression on breast.</li> </ol>

# Warranty

---

## ATEC Breast Biopsy and Excision System

Hologic, Inc. (“Hologic”) warrants that the products which are the subject of this warranty (the “Products”) will perform in substantial conformity with the specifications for the products which are described in operating manuals or instructions for use provided by Hologic for the Products and that the Products will be free from defects in material and workmanship under normal use and proper operating conditions for the warranty period shown below, assuming the performance of ordinary preventative maintenance. Hologic’s obligation under this warranty is limited to the repair or replacement, at its option, of any Product or part thereof, which has been returned to Hologic for examination within the applicable time period described below and which examination confirms, to Hologic’s satisfaction, such Product or part to be defective. This warranty does not apply to any Product, or part thereof, that has been: (1) adversely affected due to use with devices manufactured or distributed by persons not authorized by Hologic, (2) repaired, moved or altered by persons not authorized by Hologic in a way so as to, in Hologic’s judgment, affect its stability or reliability, (3) subjected to improper use, negligence or accident, or as to which the purchaser or user has failed to implement all updates or other instructions provided by Hologic, or (4) used other than in accordance with the instructions for such Product established by Hologic in the operating manuals or instructions for use provided by Hologic or with standards generally accepted in the industry for similar products.

Products are warranted for the following periods beginning on the date of shipment:

- |   |                               |
|---|-------------------------------|
| • Console unit (inclusive of power cord and footswitch) | One (1) Year, parts and labor |
| • ATEC Stereotactic Adapter                             | One (1) Year, parts and labor |
| • Eviva Stereotactic Adapter                            | One (1) Year, parts and labor |

Replacement parts supplied under this warranty shall be warranted for the remaining portion of the original warranty for the Product as to which the replacement part is utilized or a period of ninety (90) days from the date of shipment, whichever period is longer.

Disposable supplies shall be warranted to conform to published specifications for a period ending on the expiration date shown on their respective packages.

THIS WARRANTY CONSTITUTES THE EXCLUSIVE REMEDY OF THE PURCHASER OR USER AND INCORPORATES THE ONLY WARRANTIES MADE BY HOLOGIC AND IS IN LIEU OF ALL OTHER WARRANTIES, EXPRESSED OR IMPLIED BY LAW, LEGISLATION OR OTHERWISE ARISING AND WHICH ARE HEREBY EXPRESSLY EXCLUDED, AND ALL SUCH WARRANTIES, INCLUDING, WITHOUT LIMITATION, THE WARRANTIES OF MERCHANTABILITY, SATISFACTORY QUALITY, FITNESS FOR A PARTICULAR PURPOSE AND FITNESS FOR ALL OTHER PURPOSES EXCEPT AS SPECIFICALLY PROVIDED FOR IN THE OPERATING MANUALS AND INSTRUCTIONS FOR USE PROVIDED BY HOLOGIC, AS APPLICABLE, ARE HEREBY EXPRESSLY DISCLAIMED AND EXCLUDED. THIS WARRANTY SETS FORTH THE ENTIRE OBLIGATION AND LIABILITY OF HOLOGIC AS TO THE SALE AND USE OF HOLOGIC’S PRODUCTS. IN NO EVENT SHALL HOLOGIC BE LIABLE FOR SPECIAL, INCIDENTAL, INDIRECT OR CONSEQUENTIAL DAMAGES, INCLUDING, WITHOUT LIMITATION, DAMAGES RESULTING FROM LOSS OF USE, PROFITS, BUSINESS OR GOODWILL EVEN IF HOLOGIC IS ADVISED OF THE POSSIBILITY OF SUCH DAMAGES, IT BEING UNDERSTOOD THAT THE PURCHASER OR CUSTOMER MAY CHOOSE TO MAKE ITS OWN INSURANCE OR OTHER ARRANGEMENTS TO REDUCE ANY SUCH DAMAGES IT MAY INCUR. IN ANY EVENT, HOLOGIC’S LIABILITY FOR ANY DAMAGES UNDER THIS WARRANTY WILL NOT EXCEED THE TOTAL PURCHASE PRICE FOR THE PRODUCT. THIS WARRANTY DOES NOT AFFECT STATUTORY OBLIGATIONS WHICH MAY NOT BE DISCLAIMED OR LIMITED BY APPLICABLE LAW.

Hologic neither assumes nor authorizes any other person to assume for it any liability in connection with the sale or use of any Products. Hologic reserves the right to make changes to Products built and/or sold by it at any time without incurring any obligation to make the same or similar changes on Products previously built and/or sold. This warranty and the rights and obligations hereunder shall be construed under and governed by the laws of Massachusetts, United States of America. Any disputes arising under this warranty must be brought exclusively in the relevant federal or state district courts located in the Commonwealth of Massachusetts.

# Service and Maintenance

Hologic offers a variety of Extended Service Protection and Preventive Maintenance options. For additional information, please visit the Hologic website at [www.hologic.com](http://www.hologic.com) or contact your Sales Representative, Customer Support or your distributor.

## ATEC Users in the United States

All users of the ATEC Sapphire unit in the United States and Canada should contact their Hologic Sales Representative or the Customer Service Department for questions, comments, and/or technical service issues.

If you believe the ATEC Sapphire Unit requires service or repair please contact Hologic ATEC Technical Service Support at 888-355-7876, option 2. You may also contact Customer Support at 877-887-8767 and ask to be connected to the ATEC Technical Service Department.

## Other International ATEC Users

All other international users of the ATEC Sapphire unit should contact their distributor directly with questions, comments and/or technical service issues.

### RECOMMENDED MAINTENANCE SCHEDULE

Activity	Frequency	Action
Inspect footswitch cord	Weekly	Verify that the 90° connectors are facing toward rear of the console. Verify that the footswitch cord is wrapped in the counterclockwise (CCW) direction around the cord management plate. Visually inspect tubing located between the footswitch connectors and the footswitch cord sheath for kinking.
Inspect vacuum line assembly	Weekly	Visually inspect for fluid or moisture in the tubing or any discoloration to the white side of the in-line hydrophobic filter.
Inspect power cord	Quarterly	Visually inspect for cuts and damage to the outside cover and strain relief.
Test current leakage	Annually	Verify current leakage is less than 300 microamps.
Test power cord resistance	Annually	Verify power cord resistance is less than 500 milliohms.
Preventative Maintenance	Recommended every 18 months	To be performed only by Hologic Technical Services or a Hologic certified technician; contact Technical Support for details about Preventative Maintenance and/or Biomedical training.

The ATEC Sapphire unit includes several external components which can be replaced in the field.

These external components include:

1. ATEC Footswitch Assembly
2. ATEC Vacuum Line Assembly
3. ATEC Power Cord

The following photos or diagrams offer specific replacement instructions for the external components of the console unit referenced above.

## FIELD REPLACEABLE ITEMS

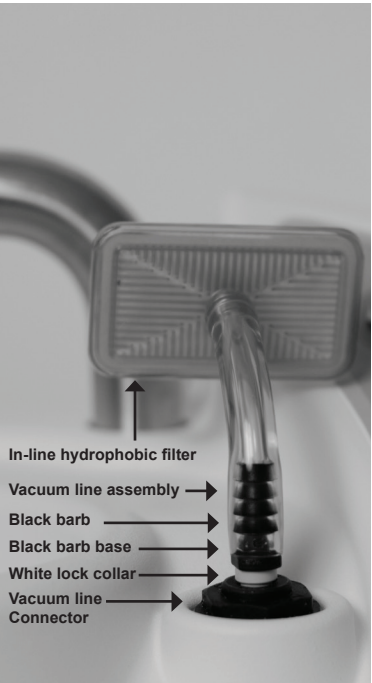
Item	Instructions
<p>Footswitch Assembly</p>  <p>Labels in diagram:            Back of Console            Cord Management Plate            FootSwitch Cord            FootSwitch</p>	<p>Removal (with the console powered off)</p> <ol style="list-style-type: none"> <li>1. Completely unwrap and remove footswitch cord from cord management plate</li> <li>2. Disconnect upper and lower footswitch connectors by pulling out the top lock collar and pushing in the bottom lock collar. Once disconnected, call Hologic Technical Service for product return instructions.</li> </ol> <p>Installing new footswitch assembly (with the console powered off)</p> <ol style="list-style-type: none"> <li>1. Connect footswitch connectors so that the connectors point toward the back of the console.</li> <li>2. Wrap the footswitch counter clockwise around cord management plate.</li> </ol> <p>Verification of Installation</p> <ol style="list-style-type: none"> <li>1. Turn console power on.</li> <li>2. The console will beep; and will then default to the biopsy mode.</li> <li>3. Plug vacuum inlet line with thumb or finger.</li> <li>4. With console in Biopsy mode, depress footswitch pedal and hold.</li> <li>5. Check for solid <b>green</b> "Vacuum Ready" light, the console gives an audible beep at the end of each cycle and cycling of the Pinch Valve.</li> <li>6. Release footswitch pedal and verify that the solid <b>green</b> vacuum light turns off and cycling stops. Vacuum releases from thumb.</li> </ol>
<p>Vacuum Line Assembly</p>  <p>Labels in diagram:            In-line hydrophobic filter            Vacuum line assembly            Black barb            Black barb base            White lock collar            Vacuum line Connector</p>	<p>Removal (with the console powered off)</p> <ol style="list-style-type: none"> <li>1. Locate the white lock collar where the vacuum line assembly attaches to the console.</li> <li>2. Lift up on the vacuum line assembly approximately one-eighth inch, exposing a gap between the white collar and black barb base.</li> <li>3. Insert a small slotted screwdriver into the gap created, then press and hold down the white collar.</li> <li>4. While holding down the white collar, pull the vacuum line assembly up and out of the vacuum line assembly connector.</li> </ol> <p>Installation (with the console powered off)</p> <ol style="list-style-type: none"> <li>1. Press the new vacuum line assembly into the vacuum line assembly connector.</li> <li>2. Pull up to verify that it has locked into the connector. The vacuum line assembly will have a small amount of vertical movement, but should not pull free of the connector. Note: Do not twist line as you pull up.</li> </ol> <p>Verification of Installation</p> <ol style="list-style-type: none"> <li>1. Turn console power on.</li> <li>2. You will hear the console beep; it will then default to the biopsy mode.</li> <li>3. Plug the tip of the vacuum line assembly with thumb or finger.</li> <li>4. Press the Setup button on the console.</li> <li>5. Verify that the solid <b>green</b> vacuum ready light is illuminated, indicating that the system is functioning properly.</li> <li>6. Turn console power off.</li> </ol>

**Item****Power Cord****Instructions**

Removal (with the console powered off)

1. Unplug console power cord from wall outlet.
2. Completely unwrap and remove power cord from cord management plate.
3. With #1 Philips screwdriver, loosen fastener located on bottom of retaining bracket.
4. Disconnect power cord connector from power receptacle.

Installation (with the console powered off)

1. Press the new power cord into the cord receptacle.
2. With #1 Philips screwdriver, tighten fastener located on bottom of retaining bracket.

Verification of Installation

1. Plug power cord into wall outlet.
2. Turn console power on.
3. Verify console powers on, beeps and defaults to the biopsy mode.
4. Turn console power off.
5. Unplug power cord from wall outlet and wrap clockwise around cord management plate.

Power Cord Connector

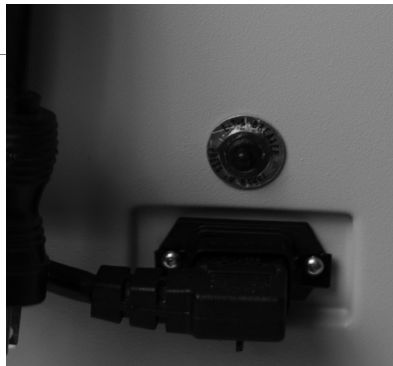

# Cleaning Instructions

---

This section provides instructions on how to clean the capital components of the ATEC Sapphire unit.

 **WARNING:** Single patient use disposable items are not intended for reuse and should not be cleaned or resterilized.

## ATEC Breast Biopsy and Excision System: Sapphire Unit

 **WARNING:** Console must be disconnected from electrical power source prior to cleaning. Failure to do so may cause electric shock and death. To clean the **ATEC Sapphire unit console**, disconnect the console from electrical power source. Periodically clean the console using a soft, damp cloth and mild detergent. Wipe dry.

 **WARNING:** Do not immerse console in water. Immersion in water will cause console damage and may cause electric shock or death.

## ATEC Footswitch

Clean the ATEC Footswitch thoroughly with mild detergent and wipe dry.

 **WARNING:** Do not immerse the footswitch in water. Immersion in water may cause damage to the footswitch.

# Owner's Record

---

## ATEC Breast Biopsy and Excision System: Sapphire Unit

The serial number of your ATEC Breast Biopsy and Excision System: Sapphire unit is located on the panel on the left side of the console. Record this number in the space provided below. Refer to this serial number whenever you contact Hologic Customer Support or your distributor regarding your ATEC Sapphire unit.

**REF** Model Number: ATEC Sapphire

**SN** Serial Number: \_\_\_\_\_

# Specifications

## ATEC Breast Biopsy and Excision System: Sapphire Unit

### ATEC Sapphire Console

	120V/60 Hz Model	240V/50 Hz Model
Size	25 in. Wide (63cm) 37 in. High (93cm) 21 in. Deep (53cm)	25 in. Wide (63cm) 37 in. High (93cm) 21 in. Deep (53cm)
Footprint	525 in (3400 cm )	525 in (3400 cm)
Weight	100 lbs. (45kg)	100 lbs. (45kg)
Maximum Power	1320W	1200W
Voltage	120V AC	240V AC
Frequency	60 Hz	50 Hz
Maximum Current	11 A	5 A
Fuse	12 A, Breaker	6 A, Breaker
Power Cord Length	15 ft. (5m)	15 ft. (5m)
Vacuum Generated	~28"Hg (71 cmHg) at sea level	~28"Hg (71 cmHg) at sea level



# Specifications

## ATEC Breast Biopsy and Excision System: Sapphire Unit

### ATEC Footswitch - MRI Compatible

Size	6 in. (16cm) Long	4 in. (9cm) Wide	2 in. (5cm) High
Weight	1 lb. (0.5kg)		
Tubing Length	20 ft. (6m)		

### ATEC Handpiece

Handpiece Size	1.66 in. (4.22cm) diameter x 10.56 in. (26.83cm) long		
Weight	7.26 oz (204g)		
Needle Length	3.52 in. (9cm)	4.72 in (12cm)	5.50 in (14cm)
Outer Cannula Diameter	12g - 0.111 in. (2.82mm)	9g - 0.148 in. (3.76mm)	
Inner Cannula Diameter	12g - 0.084 in (2.13mm)	9g - 0.118 in. (3mm)	
Aperture Length	0.787 in (20mm)	0.472 in (12mm)	
Tubing Set Length	12 ft. (3.66m) for US/STX handpiece		20 ft. (6.10m) for MRI handpiece
Sterilization	Gamma Irradiation		

### Eviva Biopsy Device

Handpiece Size	1.81 in. (4.60cm) High x 1.48 in. (3.76cm) Wide x 8.17 in. (20.75cm) long	
Weight	8.7 oz (246.6g)	
Needle Length	3.93 in. (10cm)	5.11 in (13cm)
Outer Cannula Diameter	12g - 0.111 in. (2.82mm)	9g - 0.148 in. (43.76mm)
Inner Cannula Diameter	12g - 0.080 in (2.03mm)	9g - 0.118 in. (3mm)
Aperture Length	0.787 in (20mm)	0.472 in (12mm)
Tubing Set Length	12 ft. (3.66m) for STX handpiece	
Sterilization	Gamma Irradiation	

### Storage and Transport Environmental Conditions

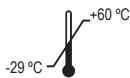

An ambient temperature of -29 °C to +60 °C (-20 °F to +140 °F)



A relative humidity range of 30% to 85% excluding condensation

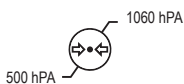

An atmospheric pressure range of 500hPa to 1060hPa



# Equipment Operating Environmental Conditions

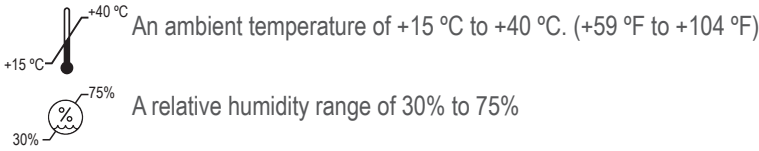

Operating altitude: less than or equal to 3,657 meters (12,000 ft.) above sea level

## Electromagnetic Emissions

1. The ATEC Sapphire Console must be installed and put into service according to the guidance provided in these instructions to ensure its electromagnetic compatibility. Refer to the electromagnetic emissions and immunity tables in this document.
2. Portable and mobile RF communications equipment can affect the ATEC Sapphire Console. Refer to the electromagnetic immunity tables in the Specifications section for recommended separation distances.
3. **WARNING:** This equipment/system is intended for use by healthcare professionals only. This equipment/system may cause radio interference or may disrupt the operation of nearby equipment. It may be necessary to take mitigation measures, such as re-orienting or relocating the ATEC Sapphire Console or shielding the location.
4. The use of any cables or accessories other than those specified in these instructions may result in increased emissions or decreased immunity of the ATEC Sapphire Console.
5. The ATEC Sapphire Console should not be used adjacent to or stacked with other equipment. If adjacent or stacked use is necessary, the ATEC Sapphire Console should be observed to verify normal operation in the configuration in which it will be used.

### GUIDANCE AND MANUFACTURER’S DECLARATION – ELECTROMAGNETIC EMISSIONS

The ATEC Sapphire Console is intended for use in the electromagnetic environment specified below. The customer or the user of the ATEC Sapphire Console should ensure that it is used in such an environment.

**TABLE 6: ATEC Sapphire (120V)**

Emissions Test	Compliance	Electromagnetic environment - Guidance
RF emissions CISPR 11	Group 1	The ATEC Sapphire uses RF energy only for its internal function. Therefore, its RF emissions are very low and are not likely to cause any interference in nearby electronic equipment.  The ATEC Sapphire is suitable for use in all establishments other than domestic, and those directly connected to the public low-voltage power supply network that supplies buildings used for domestic purposes.
RF emissions CISPR 11	Class A	
Harmonic emissions IEC 61000-3-2	Not Applicable	
Voltage Fluctuations/flicker emissions IEC 61000-3-3	Not Applicable	

**TABLE 7: ELECTROMAGNETIC IMMUNITY**

Immunity Test	EN/IEC 60601 Test Level	Compliance Level	Electromagnetic Environment - Guidance
Electrostatic discharge (ESD) EN/IEC 61000-4-2	±6 kV Contact ±8 kV Air	±6 kV Contact ±8 kV Air	Floors should be wood, concrete or ceramic tile. If floors are covered with synthetic material, the relative humidity should be at least 30%.

Immunity Test	EN/IEC 60601 Test Level	Compliance Level	Electromagnetic Environment - Guidance
Electrical fast transient/ burst EN/IEC 61000-4-4	±2 kV for power supply lines ±1 kV for input/output lines	±2 kV for power supply lines	Mains power quality should be that of a typical commercial or hospital environment.
Surge EN/IEC 61000-4-5	±1 kV line(s) to line(s) ±2 kV line(s) to earth	±1 kV line(s) to line(s) ±2 kV line(s) to earth	Mains power quality should be that of a typical commercial or hospital environment.
Voltage Dips/ Dropout EN/IEC 61000-4-11	>95 % dip for 0.5 cycle  60 % dip for 5 cycles  30 % dip for 25 cycles  >95 % dip for 5 s	>95 % dip for 0.5 cycle  60 % dip for 5 cycles  30 % dip for 25 cycles  >95 % dip for 5 s  This condition causes the ATEC Sapphire Console to shut down and then return to Biopsy mode.	Mains power quality should be that of a typical commercial or hospital environment. If the user of the ATEC Sapphire Console requires continued operation during power mains interruptions, it is recommended that the ATEC Sapphire Console be powered from an uninterruptible power supply or battery.
Power Frequency 50/60Hz Magnetic Field EN/IEC 61000-4-8	3A/m	3A/m	Power frequency magnetic fields should be that of a typical commercial or hospital environment.
Conducted RF IEC 61000-4-6  Radiated RF IEC 61000-4-3	3 Vrms 150 kHz to 80MHz  3 V/m 80 MHz to 2.5 GHz	3 Vrms  3 V/m	Portable and mobile RF communications equipment should be used no closer to any part of the ATEC Sapphire Console, including cables, than the recommended separation distance calculated from the equation applicable to the frequency of the transmitter.  Recommended separation distance d=1.2√P 150 kHz to 80 MHz d=1.2√P 80 MHz to 800 MHz d=2.3√P 800 MHz to 2.5 GHz where P is the maximum output power rating of the transmitter in watts (W) and d is the recommended separation distance in meters (m).  Field strengths from fixed RF transmitters, as determined by an electromagnetic site survey, <sup>a</sup> should be less than the compliance level in each frequency range. <sup>b</sup>  Interference may occur in the vicinity of equipment marked with the following symbol: 

NOTE 1: At 80 MHz and 800 MHz, the higher frequency range applies.

NOTE 2: These guidelines may not apply in all situations. Electromagnetic propagation is affected by absorption and reflection from structures, objects and people.

<sup>a</sup>Field strengths from fixed transmitters, such as base stations for radio (cellular/cordless) telephones and land mobile radios, amateur radio, AM and FM radio broadcast and TV broadcast cannot be predicted theoretically with accuracy. To assess the electromagnetic environment due to fixed RF transmitters, an electromagnetic site survey should be considered. If the measured field strength in the location in which the ATEC Sapphire Console is used exceeds the applicable RF compliance level above, the ATEC Sapphire Console should be observed to verify normal operation. If abnormal performance is observed, additional measures may be necessary, such as re-orienting or relocating the ATEC Sapphire Console.

<sup>b</sup> Over the frequency range 150 kHz to 80 MHz, field strengths should be less than 3 V/m.

**TABLE 8: RECOMMENDED SEPARATION DISTANCES BETWEEN PORTABLE AND MOBILE RF COMMUNICATIONS EQUIPMENT AND THE ATEC SAPPHIRE CONSOLE**

The ATEC Sapphire Console is intended for use in the electromagnetic environment in which radiated RF disturbances are controlled. The customer or the user of the ATEC Sapphire Console can help prevent electromagnetic interference by maintaining a minimum distance between portable and mobile RF communications equipment (transmitters) and the ATEC Sapphire Console as recommended in the following table, according to the maximum output power of the communications device.

Rated maximum output power of transmitter (W)	Separation distance according to frequency of transmitter (m)		
	150 kHz to 80 MHz $d=1.2\sqrt{P}$	80 MHz to 800 MHz $d=1.2\sqrt{P}$	800 MHz to 2.5 GHz $d=1.2\sqrt{P}$
0.01	0.12	0.12	0.23
0.1	0.37	0.37	0.74
1	1.2	1.2	2.3
10	3.7	3.7	7.4
100	12	12	23

For transmitters rated at a maximum output power not listed above, the recommended separation distance  $d$  in meters (m) can be estimated using the equation applicable to the frequency of the transmitter, where  $P$  is the maximum output power rating of the transmitter in watts (W) according to the transmitter manufacturer.

NOTE 1: At 80 MHz and 800 MHz, the separation distance for the higher frequency range applies.

NOTE 2: These guidelines may not apply in all situations. Electromagnetic propagation is affected by absorption and reflection from structures, objects and people.

## Classification



Type of protection against electric shock: Class I

Degree of protection against electric shock: Type BF

Degree of protection against the ingress of water: Ordinary

Mode of Operation: Continuous

## Disposal



















Equipment to be disposed in compliance with European Directive 2002/96/EC on Waste Electrical and Electronic Equipment (WEEE).













## More Information

For product availability, or other information, contact your Hologic Representative or call Customer Support toll free at 877-887-8767. If you are an international customer, please contact your distributor for more information. To report a quality issue, contact the Quality line at 888-355-7876 option 1.

# Symbols

The following symbols may be found on the product labeling for the ATEC Breast Biopsy and Excision System:

Symbol	Definition
	Do not re-use
	Caution, consult accompanying documents
	Consult Instructions for use
	Upper limit of temperature
	Use by date
	Batch code
	Catalogue number
	Sterilized using irradiation
	Do not re-sterilize
	Do not use if package is damaged
	Manufacturer
	Number of Devices Enclosed
	Caution: Federal (USA) law restricts this device to sale by or on the order of a physician.
	Expiration date is represented by the following: YYYY represents the year MM represents the month DD represents the day
	MR Conditional - an item that has been demonstrated to pose no known hazards in a specified MR environment with specified conditions of use. Field conditions that define the specified MR environment include field strength, spatial gradient, dB/dt (time rate of change of the magnetic field), radio frequency (RF) fields, and specific absorption rate (SAR). Additional conditions, including specific configurations of the item, may be required.
	Serial Number
	This device contains di-(2ethylhexyl) phthalate; DEHP

Symbol	Definition
	Authorised Representative in the European Community
	Humidity Limitation
	Temperature Limitation
	Non - Sterile
	To identify a type BF applied part complying with IEC 60601-1. Note 1 - B = Body. Note 2 - F = Floating applied part. ATEC and Eviva biopsy devices
	Alternating Current
	Manually Reset Breaker
	Keep away from rain
	Dangerous Voltage
	WEEE Symbol - indicates separate collection of electrical and electronic equipment in accordance with European Directive 2002/96/EC on Waste Electrical and Electronic Equipment (WEEE)
	Atmospheric pressure limitation
	Equipotential Ground

# Important Contact Information: U.S. Customers and Canadian Customers

---

## ATEC Breast Biopsy and Excision System: Sapphire Unit

### Sales Representative

Name: \_\_\_\_\_

Phone: \_\_\_\_\_

Email: \_\_\_\_\_

### Clinical Education Specialist

Name: \_\_\_\_\_

Phone: \_\_\_\_\_

Email: \_\_\_\_\_

#### **Hologic Customer Support:**

csupport@hologic.com

+1 877-887-8767

#### **Hologic Quality:**

quality.reporting@hologic.com

+1 888-355-7876

**Important Contact Information:  
For all other International Customers**

---

**ATEC Breast Biopsy and Excision System: Sapphire Unit**

**Distributor or Local Hologic Sales Representative Information**

Name: \_\_\_\_\_

Phone: \_\_\_\_\_

Email: \_\_\_\_\_

Country: \_\_\_\_\_

## Appendix A: Stereotactic Adapter

When performing a biopsy under stereotactic guidance, a stereotactic adapter is required to hold the ATEC handpiece and the Eviva biopsy device in place on the stereotactic system.

Hologic offers four stereotactic adapter models for the ATEC handpiece (refer to Table 5), which are depicted in figures 6 thru 9. Various stereotactic adapter models are offered for the Eviva biopsy device (refer to Table 4). For additional instructions on the Eviva adapters and devices, please refer to the Eviva Instructions for Use (IFU).

### Performing a Biopsy Using an ATEC Stereotactic Adapter

1. With the clear protective sleeve covering the outer cannula, slide the ATEC handpiece forward onto the stereotactic adapter until the ring on the front of the ATEC handpiece engages with the guide ring on the front of the stereotactic adapter.
2. Lock the ATEC handpiece into the stereotactic adapter by sliding the handpiece retaining clamp into the lock position.
3. Remove the protective sleeve covering the outer cannula.
4. Advance the device to the desired pre-fire coordinates provided by the imaging system. If it is desirable to “rapid advance” the ATEC handpiece into the target area, pull the cocking lever away from the cradle about 80° until there is no further forward movement. The cocking lever will return by spring action to its at-rest position.

**Note:** The stereotactic adapter can only be cocked if the handpiece retaining clamp is in the lock position.

5. To “rapid advance” the ATEC handpiece into the target area, pull the release/firing knob located on either side of the stereotactic adapter outward of a minimum of 1/8” and then push the knob downward.
6. To remove the handpiece from the adapter, place console in “Biopsy” mode in order to close the aperture prior to removal of handpiece from biopsy cavity. Slide the adapter with handpiece back. Unlock the retaining clamp and remove handpiece from adapter.
7. Immediately following the procedure, clean the stereotactic adapter as recommended in the Cleaning Instructions section of this Appendix.
8. For additional training or questions on specific stereotactic applications, please contact your regional Clinical Education Specialist or Hologic Customer Support at 1-877-887-8767. If you are an international customer, please contact your distributor with questions.

**NOTE:** Complete training and understanding of your stereotactic device should be provided by your stereotactic system vendor.

FIGURE 6: ATEC STX-1

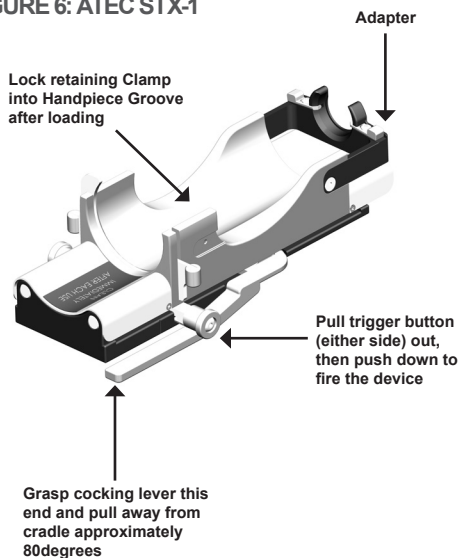

FIGURE 7: ATEC STX-2

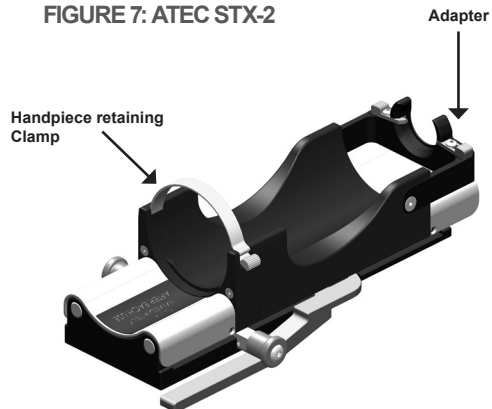



FIGURE 8: ATEC STX-2F

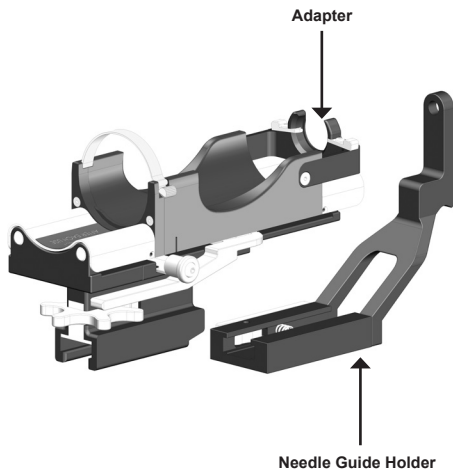
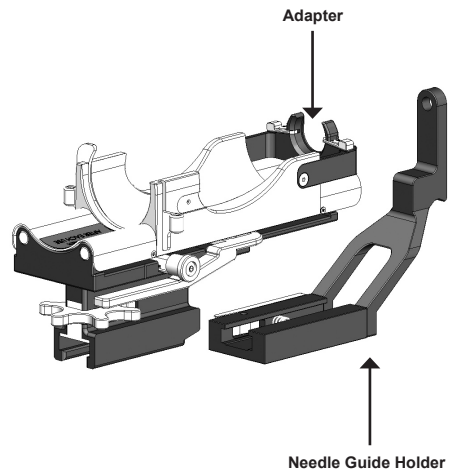

FIGURE 9: ATEC STX-FISCHER



## Cleaning Instructions

---

Follow these instructions to clean the Stereotactic Adapter:

1. Upon completion of the biopsy procedure, immediately rinse the adapter with warm water.
2. Spray the adapter with a cleaner.

**CAUTION:** The following products are NOT RECOMMENDED as they may damage the exposed components:

- a. Bleach based cleaning agents.
  - b. Hydrogen Peroxide
  - c. Any cleaners/disinfectants with a pH of less than 4 or greater than 10
3. Allow the necessary time for the chosen cleaner to disinfect the components.
  4. Rinse the adapter with warm water.
  5. Wipe the adapter dry with a cloth or a paper towel.
  6. Cycle hub retaining clamps, handpiece retaining clamp, cock and fire adapter.
  7. Re-Clean the stereotactic adapter if any component does not perform properly.

**Note:** There are many configurations of stereotactic systems available. The ATEC stereotactic adapter configurations depicted in this manual may require a unique fitting to connect to your particular manufacturer/model. Please contact Hologic Customer Support at 1-877-887-8767 if you believe this accessory, along with the appropriate instructions, was omitted. If you are an international customer, please contact your distributor directly with questions, comments, and/or technical service issues.

© 2014-2015 Hologic Inc. All rights reserved. Hologic, ATEC, Eviva, Multicare, Affirm, and Stereoloc are trademarks and/or registered trademarks of Hologic, Inc. and/or its subsidiaries, in the United States and/or other countries. All other trademarks, registered trademarks, and product names used within this document are the property of their respective owners.

MAN-03327-001 Rev. 005



A large, faint, circular watermark logo is centered on the page. It features a stylized 'H' and 'O' intertwined within a circular border.

**HOLOGIC<sup>®</sup>**

Hologic, Inc. 250 Campus Drive Marlborough, MA 01752 USA  
[www.hologic.com](http://www.hologic.com) 877.887.8767