



**Site Planning and Pre-Installation Guide for Mobile Use**  
MAN-03170 Revision 005



# **Selenia<sup>®</sup> Dimensions<sup>®</sup>**

Digital Mammography System

Digital Tomosynthesis System

## **Site Planning and Pre-Installation Guide for Mobile Use**

Part Number MAN-03170

Revision 005

December 2017

**HOLOGIC<sup>®</sup>**

## **Technical Support**

USA: +1.877.371.4372

Europe: +32 2 711 4690

Asia: +852 37487700

Australia: +1 800 264 073

All Other: +1 781 999 7750

© 2012–2017 Hologic, Inc. Printed in the USA. This manual was originally written in English.

Hologic, 3Dimensions, Dimensions, Selenia, Affirm, FAST Paddle, SecurView, SecurXchange, and associated logos are trademarks and/or registered trademarks of Hologic, Inc., and/or its subsidiaries in the United States and/or other countries. All other trademarks, registered trademarks, and product names are the property of their respective owners.

This product may be protected by one or more U.S. or foreign patents as identified at [www.Hologic.com/patents](http://www.Hologic.com/patents)

# Table of Contents

List of Figures	vii
List of Tables	ix
<b>1: Introduction and General Information</b>	<b>1</b>
1.1 Introduction	1
1.2 Conditions for Safety and Other Precautions	1
1.3 System Description	3
1.4 System Location Considerations	4
1.5 Safety	5
1.5.1 Isolation Integrity	5
1.5.2 Shielding	5
1.5.3 Remote X-ray On/Power On Indicators	5
1.5.4 The X-ray Interlock	6
1.6 Compliance	6
1.6.1 Compliance Requirements	6
1.6.2 Compliance Statements	8
1.6.3 Electromagnetic Compatibility	9
<b>2: Specifications and Reference Information</b>	<b>13</b>
2.1 Product Measurements	13
2.1.1 Tubestand (Gantry with C-Arm)	13
2.1.2 Acquisition Workstation-Mobile Dimensions Specifications	14
2.2 Mobile Specifications	15
2.2.1 Shock and Vibration Limits	15
2.2.2 Coach Environment	15
2.3 Electrical Input	16
2.3.1 Tubestand	16
2.3.2 Acquisition Workstation	16
2.3.3 Coach UPS Recommendations	16
2.4 Center of Gravity Reference	17
<b>3: Site Planning Checklist</b>	<b>21</b>
<b>4: Room Layout Worksheet</b>	<b>38</b>



## List of Figures

Figure 1: The Selenia Dimensions System.....	3
Figure 2: Tubestand (Gantry with C-arm) Measurements.....	13
Figure 3: Mobile Universal Acquisition Workstation Measurements .....	14
Figure 4: Mobile Premium Acquisition Workstation Measurements.....	15
Figure 5: Gantry Center-of-Gravity Reference.....	17
Figure 6: Universal Acquisition Workstation Center-of-Gravity Reference.....	18
Figure 7: Acquisition Workstation Center-of-Gravity Reference (Center Mount) .....	19





## List of Tables

Table 1: Electronic Emissions .....	9
Table 2: Electromagnetic Immunity Part 1 .....	10
Table 3: Electromagnetic Immunity Part 2 .....	11
Table 4: Separation Distances for RF Equipment .....	12
Table 5: Clearance Requirements .....	22
Table 6: Power Requirements .....	24
Table 7: Environmental Requirements.....	26
Table 8: Cable Requirements.....	28
Table 9: Wireway and Threshold Requirements .....	30
Table 10: X-Ray Shielding Requirements .....	32
Table 11: Mounting Requirements .....	34



# Chapter 1 Introduction and General Information

## 1.1 Introduction

This guide is an aid for the Installation Coordinator responsible for site planning and preparation. It contains all product information, specifications, and directions necessary for determining the installation requirements. All information in this guide is important and relevant to the planning process.



---

**Caution:**

**Ensure that all installations meet local regulations. A licensed electrician must perform the necessary electrical services.**

---



---

**Caution:**

**Hologic strongly recommends using experienced contractors who specialize in constructing mobile medical vans. Hologic will not warrant systems going into recreational vehicles that may have the required space, but not the required protection from shock and vibration.**

---



---

**Note**

Hologic is not responsible for the mounting scheme in the coach.

---



---

**Note**

The mounting diagrams provided in this manual are recommendations only; the final responsibility for proper installation belongs to the Installation Coordinator.

---

## 1.2 Conditions for Safety and Other Precautions

An acceptable, stable, clean VAC power source is required to make sure that the system meets all its performance specifications. Where available, shore power correctly supplied to the system provides the best performance. If a mobile power generator is used, you must keep the specifications for input power during all load conditions.



---

**Warning:**

**The radiation shield is not approved for mobile use and is not provided. The coach manufacturer must provide adequate shielding.**

---

# Selenia Dimensions System Mobile Site Planning and Pre-Installation Guide

## Chapter 1: Introduction and General Information

---



**Caution:**

When shore power is unavailable, mobile power sources that provide equivalent performance may be employed. (Refer to Specifications for Mobile Use.) Proper system function and performance can only be ensured if continuous true sinusoidal VAC power is supplied per the system power input specifications and loading characteristics. Intermittently, the power source must provide 65 Amps at 208 VAC for minimum of 5 seconds, and 4 Amps maximum continuous otherwise. This load must be supported once every 30 seconds. In the event of shore or mobile power service interruption, the UPS must be capable of providing the operational power described above for a minimum of 4 minutes. Acquisition Workstation and Gantry power must be fed on separate dedicated circuits. The use of an uninterruptible power supply with active line conditioner is recommended on each power circuit. Accordingly, all ancillary mobile coach power should be distributed by other circuits. The electrical installation must be verified to meet system power input specifications and IEC 60601-1 safety requirements after initial installation and upon each relocation of the mobile coach.

---



**Caution:**

The temperature and humidity inside the vehicle must be maintained at all times. Do not allow environmental conditions to exceed stated specifications when the unit is not in use.

---



**Caution:**

Voltages cannot change by more than  $\pm 10\%$  when the x-ray unit or other equipment (for example, heating or air conditioning) is operated.

---



**Note**

If a mobile power generator is used, make sure that it is at least 3 meters (10 feet) from the system. If this distance requirement cannot be met, additional EMI or RF shielding can be required.

---

### 1.3 System Description

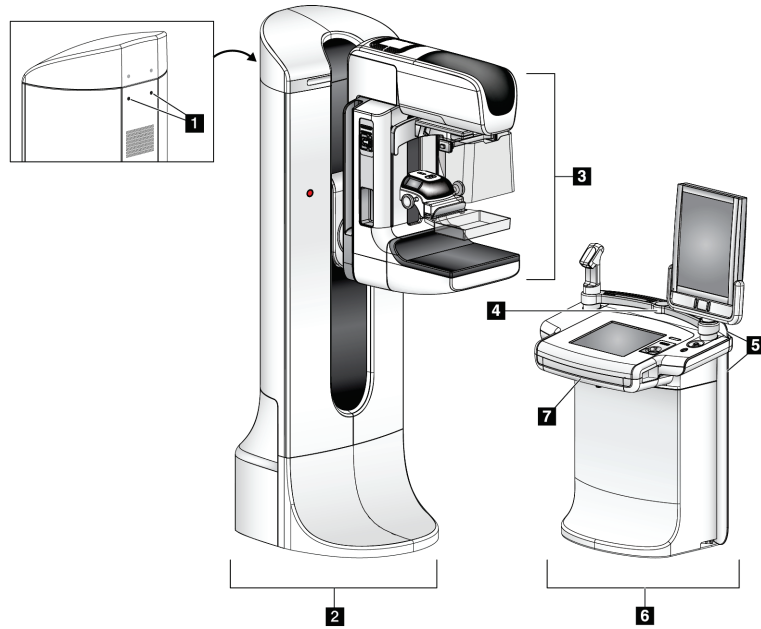

Figure 1: The Selenia Dimensions System

#### Figure Legend

1. Top Support Mounting Holes
2. The Gantry
3. The C-Arm
4. The Display Crossbar
5. Shield Fillers
6. The Acquisition Workstation
7. Keyboard Tray with Lock

### 1.4 System Location Considerations

The [Site Planning Checklist](#) on page 21 is set up to assist you with the following topics when selecting a location for the system:

1. System component sizes and weight
  - Flooring type for mounting and weight considerations
  - Doorway clearance
  - Installation space
  - Relocation of equipment
2. Room size
  - Movement clearance—Allocate space for patient and technologist movement. Avoid obstructions in the room that hinder access to the unit controls or the patient.
  - Storage—Provide convenient storage for system accessories. If it is not possible to store accessories within the exam room, arrange for safe storage close by.
3. Location for patient throughput
4. Power source requirements
  - Interlocks (room, door, lights, and so on)
  - Service access
5. Networking requirements (DICOM, PACS, and so on)
6. Physical and environmental requirements
7. Shielding requirements
8. Cabling and wireways

## 1.5 Safety

### 1.5.1 Isolation Integrity



---

**WARNING!**

To correctly isolate the system, attach only approved accessories or options to the system. Only approved personnel can change the connections.

---



---

**WARNING!**

Keep a 1.5 meter safe distance between the patient and any non-patient devices.

Do not install non-patient system components (like the Workflow Manager, a diagnostic review workstation, or a hard copy printer) in the Patient Area.

---

### 1.5.2 Shielding

#### Structural Shielding

A Medical Physicist should review the room walls in which this system is used to ensure that the room meets local guidelines for radiation shielding. Refer to the table *X-ray Shielding Requirements* in Chapter 3 of this document.

#### Operator Radiation Shield

Hologic does not supply a radiation shield for mobile systems. The coach manufacturer must supply sufficient x-ray shielding.

- The attenuation equivalence of the shield must comply with all regulatory requirements for its intended use. Minimally, the shield must comply with IEC 60601-2-45, clause 29.208.101. However, local, regional, or other regulations may impose additional shield requirements.
- The shield should be secured on all sides and appropriately attached to the coach frame in compliance with all applicable safety regulations.

### 1.5.3 Remote X-ray On/Power On Indicators

The system has provisions for remote lights which indicate when the system is On and when x rays are being taken. These lights are usually installed outside the exam room, above the door. Have a certified electrician install these lights.

The relay contacts are rated:

- 10 A, 250 VAC (normally open)
- 10 A, 30 VDC (normally open)

### 1.5.4 The X-ray Interlock

The X-ray Interlock connector at the rear of the Gantry provides a normally closed (NC) contact (5V 10mA) for the Acquisition Workstation. When an external interlock is used (for example a door or shield switch), a contact opens and an exposure cannot take place. A switch closure on the contact must occur for an exposure to occur.



**Note**

If the X-ray Interlock is utilized, the state of the interlock contacts should be displayed by visual means to the operator per IEC 60601-2-45:2011 (3rd Edition), Clause 203.6.2.1.101.

---

## 1.6 Compliance

This section describes the mammography system compliance requirements and the responsibilities of the manufacturer.

### 1.6.1 Compliance Requirements

The manufacturer has the responsibility for the safety, reliability, and performance of this equipment with the following provisions:

- The electrical installation of the room meets all requirements.
- The equipment is used according to the *User Guide*.
- The assembly operations, extensions, adjustments, changes, or repairs are performed only by authorized persons.
- The network and communication equipment is installed to meet IEC Standards. The complete system (network and communications equipment and the mammography system) must be in compliance with IEC 60601-1 and IEC 60601-1-1.



**Caution:**

**Medical Electrical Equipment needs special precautions about EMC and must be installed, put into service and used according to the EMC information provided.**

---



**Caution:**

**Portable and mobile RF communications can affect medical electrical equipment.**

---



**Caution:**

**The use of unauthorized accessories and cables can result in increased emissions or decreased immunity. To keep the isolation quality for the system, attach only approved Hologic accessories or options to the system.**

---





**Caution:**

The Medical Electrical (ME) Equipment or ME System should not be used adjacent to or stacked with other equipment. If adjacent or stacked use is necessary, make sure that the ME Equipment or ME System operates correctly in this configuration.

---



**Caution:**

This system is intended for use by healthcare professionals only. This system may cause radio interference or may disrupt the operation of nearby equipment. It may be necessary to take mitigation measures, such as re-orienting or relocating the equipment or shielding the location.

---



**Caution:**

Changes or modifications not expressly approved by Hologic could void your authority to operate the equipment.

---



**Caution:**

This equipment has been tested and found to comply with the limits for a Class A digital device, pursuant to part 15 of the FCC Rules. These limits are designed to provide reasonable protection against harmful interference when the equipment is operated in a commercial environment. This equipment generates, uses, and can radiate radio frequency energy and, if not installed and used in accordance with the instruction manual, may cause harmful interference to radio communications. Operation of this equipment in a residential area is likely to cause harmful interference in which case the user will be required to correct the interference at his own expense.

---

### 1.6.2 Compliance Statements

The manufacturer states this device is made to meet the following requirements:

- CAN/CSA - ISO 13485-03 Medical Devices – Quality Management Systems – Requirements for Regulatory Purposes (Adopted ISO 13485:2003 second edition, 2003-07-15)
- CAN/CSA C22.2 NO. 60601-1-08 Medical Electrical Equipment – Part 1: General Requirements for Basic Safety and Essential Performance (Adopted IEC 60601-1:2005, third edition, 2005-12), includes Corrigendum 1:2011; also CAN/CSA C22.2 NO. 601.1-M90 (R2005) Medical Electrical Equipment Part 1: General Requirements for Safety
- EN 60601-1:2006 Medical Electrical Equipment. General Requirements for Basic Safety and Essential Performance; also EN 60601-1:1990 +A1+A11+A12+A2+A13 Medical Electrical Equipment – General Requirements for Safety
- ETSI EN 300 330-1: V1.3.1, and ETSI EN 300 330-2: V1.5.1: 2006 – Electromagnetic compatibility and Radio spectrum Matters (ERM); Short Range Devices (SRD); Radio equipment in the frequency range 9 kHz to 25 MHz and inductive loop systems in the frequency range 9 kHz to 30 MHz
- ETSI EN 301 489-1: V1.6.1, and ETSI EN 301 489-3: V1.8.1: 2008 – Electromagnetic compatibility and Radio spectrum Matters (ERM); ElectroMagnetic Compatibility (EMC) standard for radio equipment and services
- FCC, 47 CFR Part 15, Subpart C, Section 15.225: 2009
- FDA, 21 CFR [Parts 820, 900 and 1020]
- IEC 60601-1 Ed. 3.0:2005 Medical Electrical Equipment – Part 1: General Requirements for Basic Safety and Essential Performance; also IEC 60601-1 Ed. 2.0:1988 +A1+A2:1995 Medical Electrical Equipment – General Requirements for Safety
- IEC 60601-1-1Ed. 2.0:2000 Medical Electrical Equipment - Part 1-1: General Requirements for Safety - Collateral Standard: Safety Requirements for Medical Electrical Systems
- IEC 60601-1-2 Ed. 3.0:2007 Medical Electrical Equipment – Part 1-2: General Requirements for Basic Safety and Essential Performance - Collateral Standard: Electromagnetic Compatibility – Requirements and Tests
- IEC 60601-1-3 Ed. 2.0:2008 Medical Electrical Equipment – Part 1-3: General Requirements for Basic Safety and Essential Performance – Collateral Standard: Radiation Protection in Diagnostic X-Ray Equipment; also IEC 60601-1-3 Ed. 1.0:1994 Medical Electrical Equipment – Part 1: General Requirement for Safety -3. Collateral Standard: Requirements for Radiation Protection in Diagnostic X-ray Equipment
- IEC 60601-1-4 Ed. 1.1:2000 Medical Electrical Equipment – Part 1-4: General Requirements for Safety - Collateral Standard: Programmable Electrical Medical Systems

- IEC 60601-2-28 Ed. 2.0:2010 Medical Electrical Equipment - Part 2-28: Particular Requirements for the Basic Safety and Essential Performance of X-ray Tube Assemblies for Medical Devices; also IEC 60601-2-28 Ed. 1.0:1993 Medical Electrical Equipment – Part 2: Particular Requirements for the Safety of X-Ray Source Assemblies and X-ray Tube Assemblies for Medical Diagnosis
- IEC 60601-2-32 Ed. 1.0:1994 Medical Electrical Equipment – Part 2: Particular Requirements for the Safety of Associated Equipment of X-ray Equipment
- IEC 60601-2-45 Ed. 3.0:2011 Medical Electrical Equipment – Part 2-45: Particular Requirements for Basic Safety and Essential Performance of Mammographic X-Ray Equipment and Mammographic Stereotactic Devices; also IEC 60601-2-45 Ed. 2.0:2001 Medical Electrical Equipment Part 2-45: Particular Requirements for the Safety of Mammographic X-ray Equipment and Mammographic Stereotactic Devices
- RSS-210: Issue 7, 2007 Radio Standards Specification Low-power License-exempt Radiocommunication Devices: Category I Equipment
- ANSI/AAMI ES60601-1:2005 (IEC 60601-1:2005, MOD) Medical Electrical Equipment, Part 1: General Requirements for Basic Safety and Essential Performance, includes amendment (2010); also UL 60601-1 1st Edition: Medical Electrical Equipment, Part 1—General Requirements for Safety

### 1.6.3 Electromagnetic Compatibility

This section provides information about the electromagnetic compatibility of system per IEC 60601-1-2.

*Table 1: Electronic Emissions*

<b>Electromagnetic Emissions</b>		
The system is intended for use in the electromagnetic environment specified below. The customer or the user of the system should assure that it is used in such an environment.		
<b>Emissions Test</b>	<b>Compliance</b>	<b>Electromagnetic environment - guidance</b>
RF emissions CISPR 11	Group 1	The system uses RF energy only for its internal function. Therefore, its RF emissions are very low and are not likely to cause any interference in nearby electronic equipment.
RF emissions CISPR 11	Class A	Meets Class A Compliance.
Harmonic emissions IEC 61000-3-2	Class A	The system is suitable for use in all establishments other than domestic, and those directly connected to the public low-voltage power supply network that supplies buildings used for domestic purposes.
Voltage fluctuations/ flicker emissions IEC 61000-3-3	Complies	

# Selenia Dimensions System Mobile Site Planning and Pre-Installation Guide

## Chapter 1: Introduction and General Information

Table 2: Electromagnetic Immunity Part 1

<b>Electromagnetic Immunity – Part 1</b>			
The system is intended for use in the electromagnetic environment specified below. The customer or the user of the system should assure that it is used in such an environment.			
<b>Immunity Test</b>	<b>IEC 60601 Test Level</b>	<b>Compliance Level</b>	<b>Electromagnetic Environment - Guidance</b>
Electrostatic discharge (ESD) IEC 61000-4-2	±6 kV Contact ±8 kV Air	±6 kV Contact ±8 kV Air	Floors should be wood, concrete, or ceramic tile. If floors are covered with synthetic material, the relative humidity should be at least 30%.
Electrical fast transient/ burst IEC 61000-4-4	±2 kV for power supply lines ±1 kV for input/output lines	±2 kV for power supply lines ±1 kV for input/output lines	Mains power quality should be that of a typical commercial or hospital environment.
Surge IEC 61000-4-5	±1 kV line(s) to line(s) ±2 kV line(s) to earth	±1 kV line(s) to line(s) ±2 kV line(s) to earth	Mains power quality should be that of a typical commercial or hospital environment.
Voltage dips, short interruptions and voltage variations on power supply input lines IEC 61000-4-11	<5% Ut (>95 % dip in Ut) for 0,5 cycle  40% Ut (60 % dip in Ut) for 5 cycles  70% Ut (30 % dip in Ut) for 25 cycles  <5% Ut (>95 % dip in Ut) for 5 s	<5% Ut (>95 % dip in Ut) for 0,5 cycle  40% Ut (60 % dip in Ut) for 5 cycles  70% Ut (30 % dip in Ut) for 25 cycles  <5% Ut (>95 % dip in Ut) for 5 s	Mains power quality should be that of a typical commercial or hospital environment. If the user of the system requires continued operation during power mains interruptions, it is recommended that the system be powered from an uninterruptible power supply or battery.
Power Frequency (50/60Hz) Magnetic Field IEC 61000-4-8	3 A/m	3 A/m	Power frequency magnetic fields should be at levels characteristic of a typical location in a typical commercial or hospital environment.
NOTE Ut is the a.c. mains voltage prior to application of the test level.			

Table 3: Electromagnetic Immunity Part 2

The system is intended for use in the electromagnetic environment specified below. The customer or the user of the system should assure that it is used in such an environment.			
Immunity Test	EN/IEC 60601 Test Level	Compliance Level	Electromagnetic Environment - Guidance
Conducted RF IEC 61000-4-6	3 Vrms 150 kHz to 80MHz	[V1] = 3 V	<p>Portable and mobile RF communications equipment should be used no closer to any part of the system, including cables, than the recommended separation distance calculated from the equation applicable to the frequency of the transmitter.</p> <p><b>Recommended separation distance:</b></p> $d = \left[ \frac{3,5}{V_1} \right] \sqrt{P}$ $d = \left[ \frac{3,5}{E_1} \right] \sqrt{P} \quad 80 \text{ MHz to } 800 \text{ MHz}$ $d = \left[ \frac{7}{E_1} \right] \sqrt{P} \quad 800 \text{ MHz to } 2,5 \text{ GHz}$ <p>where <math>P</math> is the maximum output power rating of the transmitter in watts (W) and <math>d</math> is the recommended separation distance in meters (m). Field strengths from fixed RF transmitters, as determined by an electromagnetic site survey<sup>a</sup>, should be less than the compliance level in each frequency range<sup>b</sup>. Interference may occur in the vicinity of equipment marked with the following symbol:</p> 
Radiated RF IEC 61000-4-3	3 V/m 80 MHz to 2.5 GHz	[E1] = 3 V/m	
<p>NOTE 1: At 80 MHz and 800 MHz, the higher frequency range applies.</p> <p>NOTE 2: These guidelines may not apply in all situations. Electromagnetic propagation is affected by absorption and reflection from structures, objects and people.</p>			

# Selenia Dimensions System Mobile Site Planning and Pre-Installation Guide

## Chapter 1: Introduction and General Information

Table 3: Electromagnetic Immunity Part 2

The system is intended for use in the electromagnetic environment specified below. The customer or the user of the system should assure that it is used in such an environment.			
Immunity Test	EN/IEC 60601 Test Level	Compliance Level	Electromagnetic Environment - Guidance
<p><sup>a</sup> Field strengths from fixed transmitters, such as base stations for radio (cellular/cordless) telephones and land mobile radios, amateur radio, AM and FM radio broadcast and TV broadcast cannot be predicted theoretically with accuracy. To assess the electromagnetic environment due to fixed RF transmitters, an electromagnetic site survey should be considered. If the measured field strength in the location in which the system is used exceeds the applicable RF compliance level above, the system should be observed to verify normal operation. If abnormal performance is observed, additional measures may be necessary, such as re-orienting or relocating the system.</p> <p><sup>b</sup> Over the frequency range 150 kHz to 80 MHz, field strengths should be less than 3 V/m.</p>			

Table 4: Separation Distances for RF Equipment

Recommended Separation Distances for Portable and Mobile RF Communications Equipment and the system			
The system is intended for use in the electromagnetic environment in which radiated RF disturbances are controlled. The customer or the user of the system can help prevent electromagnetic interference by maintaining a minimum distance between portable and mobile RF communications equipment (transmitters) and the system as recommended below, according to the maximum output power of the communications equipment.			
Rated maximum output power of transmitter W	Separation distance according to frequency of transmitter m		
	150 kHz to 80 MHz $d = \left[\frac{3,5}{V_1}\right]\sqrt{P}$	80 MHz to 800 MHz $d = \left[\frac{3,5}{E_1}\right]\sqrt{P}$	800 MHz to 2.5 GHz $d = \left[\frac{7}{E_1}\right]\sqrt{P}$
0.01	0.12	0.12	0.23
0.1	0.37	0.37	0.74
1	1.17	1.17	2.33
10	3.7	3.7	7.38
100	11.7	11.7	23.3
For transmitters rated at a maximum output power not listed above, the recommended separation distance $d$ in meters (m) can be estimated using the equation applicable to the frequency of the transmitter, where $P$ is the maximum output power rating of the transmitter in watts (W) according to the transmitter manufacturer.			
NOTE 1: At 80 MHz and 800 MHz, the separation distance for the higher frequency range applies.			
NOTE 2: These guidelines may not apply in all situations. Electromagnetic propagation is affected by absorption and reflection from structures, objects and people.			

## Chapter 2 Specifications and Reference Information

### 2.1 Product Measurements

#### 2.1.1 Tubestand (Gantry with C-Arm)

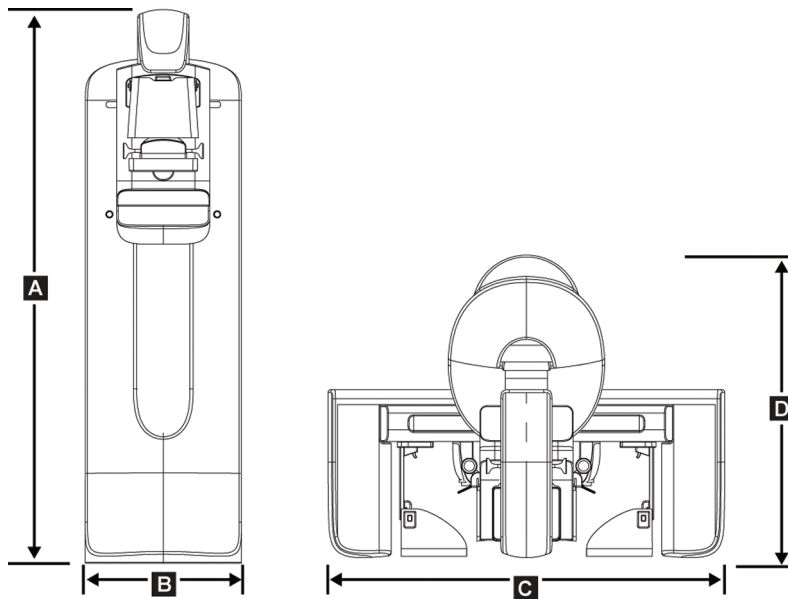
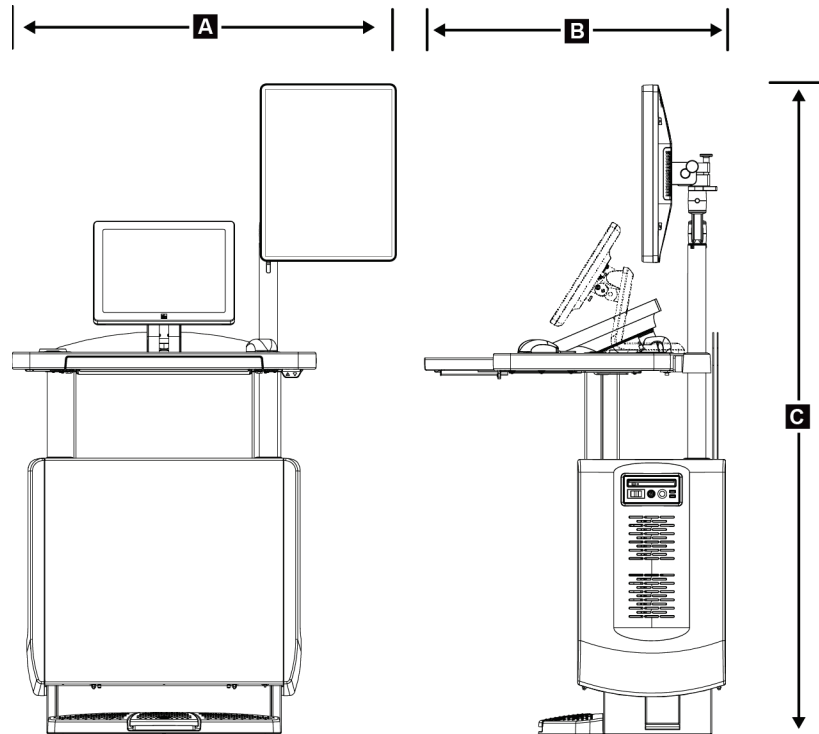

Figure 2: Tubestand (Gantry with C-arm) Measurements

A.	Height	223 cm (87.8 inches)
B.	Width	66 cm (26 inches)
C.	Width	173 cm (68.0 inches)
D.	Depth	138 cm (54.3 inches)
	Weight	Maximum of 400 kg (882 pounds)

**2.1.2 Acquisition Workstation-Mobile Dimensions Specifications**



*Figure 3: Mobile Universal Acquisition Workstation Measurements*

A.	<i>Width (maximum) with mobile display arm</i>	100 cm (39.5 inches) - series I UAWS 107 cm (42.0 inches) - series II UAWS
B	<i>Depth (maximum) with keyboard tray extended</i>	85 cm (33.5 inches)
C.	<i>Height (maximum)</i>	180 cm (71 inches)
	<i>Weight (maximum)</i>	179 kg (395 pounds)



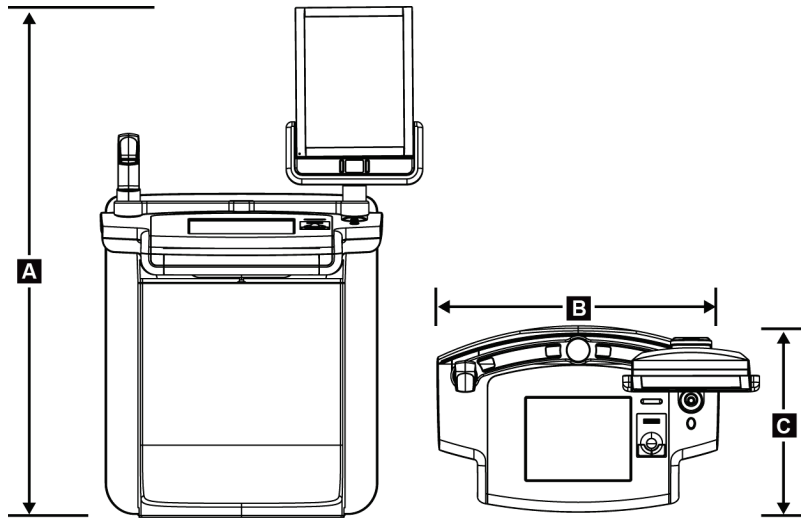

Figure 4: Mobile Premium Acquisition Workstation Measurements

A.	Height	167.6 cm (66.0 inches)
B.	Width	105.5 cm (41.5 inches)
C.	Depth	58.5 cm (23 inches)
	Weight	154 kg (340 pounds)

## 2.2 Mobile Specifications

### 2.2.1 Shock and Vibration Limits

*Vibration Limit*

Maximum of 0.30 G (2 Hz to 200 Hz), measured at the point where the system mounts to the coach.

*Shock Limit*

Maximum of 1.0 G (1/2 sine pulse), measured at the point where the system mounts to the coach. An “air ride” coach suspension is recommended.

### 2.2.2 Coach Environment

#### Operation Environment

*Temperature Range*

20 °C (68 °F) to 30 °C (86 °F)

*Relative Humidity Range*

20% to 80% without condensing moisture

#### Non-Operating Transit Environment

*Temperature Range*

10 °C (50 °F) to 35 °C (95 °F) for a maximum of 12 hours

10 °C (50 °F) to 30 °C (86 °F) indefinitely

*Maximum Rate of Temperature Change*

<10 °C/hr.

*Relative Humidity Range*

10% to 80% without condensing moisture

### 2.3 Electrical Input

#### 2.3.1 Tubestand

<i>Mains Voltage</i>	200/208/220/230/ 240 VAC $\pm 10\%$
<i>Mains Impedance</i>	Maximum line impedance not to exceed 0.20 ohms for 208/220/230/240 VAC, 0.16 ohms for 200 VAC
<i>Mains Frequency</i>	50/60 Hz $\pm 5\%$
<i>Average Current over 24 Hours</i>	< 5 A
<i>Peak Line Current</i>	4 A (65 A maximum for $\leq 5$ seconds)

#### 2.3.2 Acquisition Workstation

<i>Mains Voltage</i>	100/120/200/208/220/230/240 VAC $\pm 10\%$
<i>Mains Frequency</i>	50/60 Hz $\pm 5\%$
<i>Power Consumption</i>	< 1000 watts
<i>Duty Cycle (Standard Acquisition Workstation)</i>	10% ~ 6 minutes per hour or 2 minutes on, 18 minutes off
<i>Overcurrent Protection</i>	8A

#### 2.3.3 Coach UPS Recommendations

- Dedicated UPS for only the Gantry and Acquisition Workstation
- Dual Conversion UPS (Uninterruptible Power Supply and Power Conditioner)
- Single Phase
- Hardwired (Multi) Input 208/220/230/240
- Hardwired (Multi) Output 120/208/240
- IGBT Technology (refer to note below)
- Output Current >55Amps @ 240 VAC
- Internal Isolation Transformer (separate module not preferred)
- Power Factor Correction Technology Input Power Factor >.95 / Output Power Factor  $\geq .85$
- Output Voltage Regulation not to exceed  $\pm 3\%$  (1% typical)
- Minimum Battery Back-up time at Full charge  $\geq 7$  minutes



#### Note

If the UPS does not use IGBT Technology the UPS specification must be for a minimum 2X the systems kW rating.

Placement of the UPS relative to the detector must be a minimum of 3.05 meters (10 feet) line-of-sight.

---

## 2.4 Center of Gravity Reference

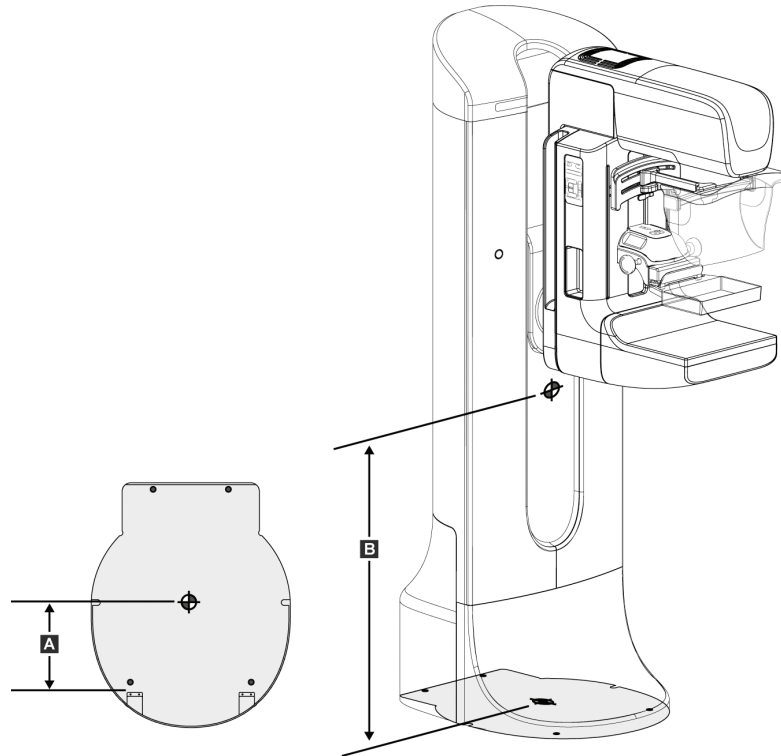

Figure 5: Gantry Center-of-Gravity Reference

- A. 31.8 cm (12.5 inches)
- B. 95.5 cm (37.6 inches)

# Selenia Dimensions System Mobile Site Planning and Pre-Installation Guide

## Chapter 2: Specifications and Reference Information

---

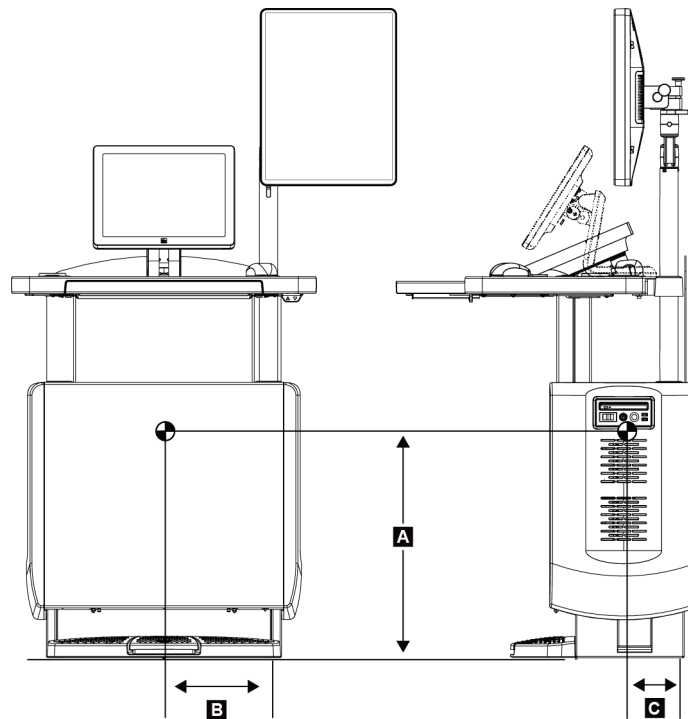

*Figure 6: Universal Acquisition Workstation Center-of-Gravity Reference*

- A. 61.7 cm (24.3 inches)
- B. 29.0 cm (11.4 inches)
- C. 14.2 cm (5.6 inches)

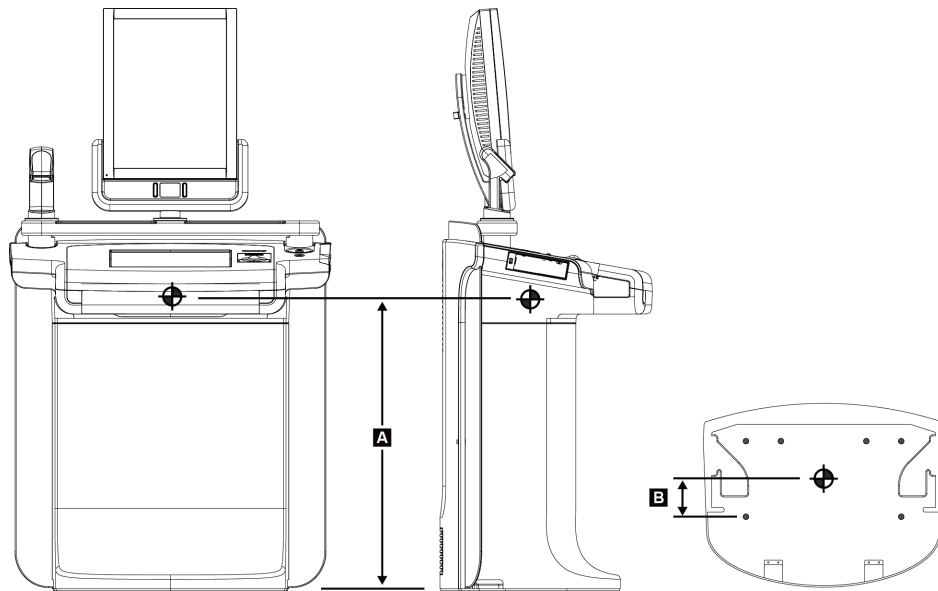

*Figure 7: Acquisition Workstation Center-of-Gravity Reference (Center Mount)*

- A. 62.9 cm (24.8 inches)
- B. 10.5 cm (4.1 inches)



# Chapter 3 Site Planning Checklist

# Selenia Dimensions System Mobile Site Planning and Pre-Installation Guide

## Chapter 3: Site Planning Checklist

Table 5: Clearance Requirements

Item	Minimum Requirements	Actual	Corrective Action	Done (Init/Date)
<b>Access Clearance</b>				
Acquisition Workstation	61 cm (2.0 feet) <i>on 3 sides</i>			
Gantry Rear	30 cm (1 feet)			
Gantry Front	76 cm (2.5 feet)			
Work Area	76 x 76 cm diameter (2.5 feet x 2.5 feet)			
<b>Working Clearance</b>				
Gantry with C-Arm	50 cm (20 inches) each side of C-Arm (for complete C-Arm rotation)			
Work and Patient Area	76.2 cm (30 inches) diameter (minimum) between Tubestand and Acquisition Workstation			
Note: Refer to the specifications.				



Additional Notes		
Note #	Topic	Notes

# Selenia Dimensions System Mobile Site Planning and Pre-Installation Guide

## Chapter 3: Site Planning Checklist

Table 6: Power Requirements

Item	Requirements	Actual	Corrective Action	Done (Init/Date)
<b>Power Requirements</b>				
Dedicated Power Line	Dedicated disconnect box with lockout capability, circuit breaker or fuse (per local codes), and remote emergency OFF trip switch if required (the location is determined by local codes).			
Acquisition Workstation	Refer to <a href="#">Electrical Input</a> on page 16.			
Light Indicator Relay Contact Ratings*	10 A, 250 VAC (N.O.) 10 A, 30 VDC (N.O.)			
Notes:				
*There are provisions in the system to accommodate local regulations that require an <b>X-ray System Power-On</b> , and <b>X-ray On Indicators</b> at the door. These lights are normally installed above the door to the exam room.				

Additional Notes		
Note #	Topic	Notes

# Selenia Dimensions System Mobile Site Planning and Pre-Installation Guide

## Chapter 3: Site Planning Checklist

Table 7: Environmental Requirements

Item	Requirements	Actual	Corrective Action	Done (Init/Date)
<b>Non-Operating/Transit</b>				
Temperature Range	10 °C (50 °F) to 30 °C (86 °F) indefinitely 10 °C (50 °F) to 35 °C (95 °F) for up to 12 hours			
Relative Humidity Range	10% to 80% non-condensing			
Maximum Rate of Temp .Change	<10 °C/hr.			
<b>Operating</b>				
Temp. Range	20 °C to 30 °C (68 °F to 86 °F)			
Relative Humidity Range	20% to 80% non condensing			
<b>Shock and Vibration Limits</b>				
Vibration Limit	Maximum of 0.30 G (2 Hz to 200 Hz), as measured at the point where the system mounts to the coach.			
Shock Limit	Not greater than 1.0 G (½ sine pulse), as measured at mounting point of system to coach. An "air ride" coach suspension is recommended.			
<b>Notes:</b> The temperature and humidity inside the vehicle must be maintained at all times. Do not allow environmental conditions to exceed stated specifications when the unit is not in use.				

# Selenia Dimensions System Mobile Site Planning and Pre-Installation Guide

Additional Notes		
Note #	Topic	Notes

# Selenia Dimensions System Mobile Site Planning and Pre-Installation Guide

## Chapter 3: Site Planning Checklist

Table 8: Cable Requirements

Item	Recommendations	Actual	Corrective Action	Done (Init/Date)
<b>Cables (Length)</b>				
Gantry Power Cable	7.5 m (25 feet) If Mains box is over 15 m (50 feet) away, custom lengths should drop 2 gauges when length is doubled.			
Workstation to Gantry Interconnect Cable	12.2 m (40 feet)			
Ground Wire	12.2 m (40 feet)			
Workstation to Gantry Interconnect (Fiber Optic Cable)	13 m (42.65 feet)			
Acquisition Workstation Power Cord	3.05 m (10 feet)			
<p><b>Notes:</b></p> <p>Strain relief for Mains cable: Cable should not flex, move, etc. Considered "permanently connected" per its safety classification.</p> <p>Hologic does not provide the Gantry power cable for some countries. If the power cable is not provided, the installed cable must meet the following requirements and all local codes that apply: 3 conductor, 8 AWG (10 mm<sup>2</sup>) copper not more than 25 feet (7.62 meters) in length.</p>				

## Selenia Dimensions System Mobile Site Planning and Pre-Installation Guide

### Chapter 3: Site Planning Checklist

Additional Notes		
Note #	Topic	Notes

# Selenia Dimensions System Mobile Site Planning and Pre-Installation Guide

## Chapter 3: Site Planning Checklist

Table 9: Wireway and Threshold Requirements

Item	Requirements	Actual	Corrective Action	Done (Init/Date)
<b>Interconnects</b>				
Wireways	Horizontal surface wireway, 1-3/4 inches x 5-1/4 inches divided with removable covers. Vertical surface flush-mounted wireway, 1-3/4 inches x 5-3/4 inches divided with removable covers. Horizontal surface mounted floor duct wireway, 1-3/4 inches x 5-1/4 inches divided with removable covers, grommeted on open end.			
Thresholds (if required)	Length depends on cable run.			
<b>Notes:</b>				



Additional Notes		
Note #	Topic	Notes

# Selenia Dimensions System Mobile Site Planning and Pre-Installation Guide

## Chapter 3: Site Planning Checklist

Table 10: X-Ray Shielding Requirements

Item	Requirements	Actual	Corrective Action	Done (Init/Date)
<b>X-ray Shielding</b>				
Customer supplied Operator Shielding	Must meet or exceed all local requirements for operator shielding.			
Vehicle	Must meet Medical Physicist's specifications.			
Mounting	Shield must be secured on all sides.			

**Notes:**

Shielding refers to the protection from leakage radiation that usually occurs during mammography exams.

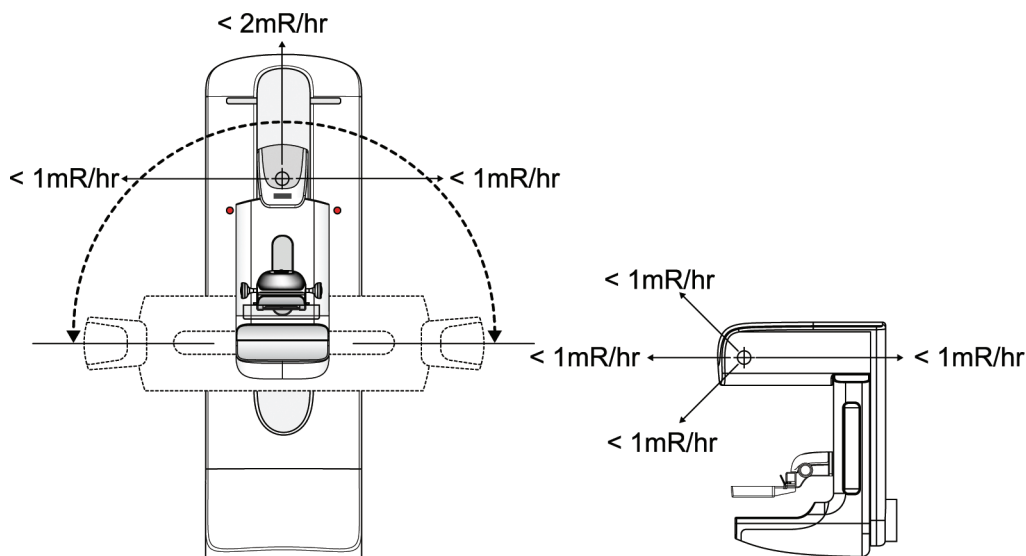

Leakage Radiation

All related x ray safety features meet 21 CFR, Chapter I, 1020.31, IEC 60601-1-3, and IEC 60601-2-45.

Typical values of x ray leakage shown are at a distance of 1 meter from the tube focal spot, at maximum kVp, and adjusted for a maximum in use duty cycle of 0.027.

Duty cycle is derived from a maximum throughput of 12 patients per hour x 4 exposures, or 48 exposures per hour with a maximum exposure time of 2 seconds.

Therefore;  $48 \times 2 = 96$  exposure seconds per hour, or  $96 \text{ exposure seconds} / 3600 \text{ seconds per hour} = 0.027$ .

The meter measures x ray leakage in units of mR/Hour.

The meter indication is multiplied by the duty cycle to get the correct leakage value ( $N \times 0.027$ ) and this is compared with the maximum allowed criteria 90 mR/Hour.

Additional Notes		
Note #	Topic	Notes

# Selenia Dimensions System Mobile Site Planning and Pre-Installation Guide

## Chapter 3: Site Planning Checklist

Table 11: Mounting Requirements

Item	Requirements	Actual	Corrective Action	Done (Init/Date)
<b>Mounting Requirements</b>				
Gantry (The Gantry base has four 11/16 inch mounting holes. Two additional threaded holes are provided at the top rear of the Gantry for additional support.)	Anchors: appropriate bolts/hardware. The floor must be able to support a minimum of 210 lb/ft <sup>2</sup> .			
Acquisition Workstation (The AWS base has four (two additional holes are available, if needed) 5/8 inch mounting holes.)	Anchors: appropriate bolts/hardware. The floor must be able to support a minimum of 210 lb/ft <sup>2</sup> .			

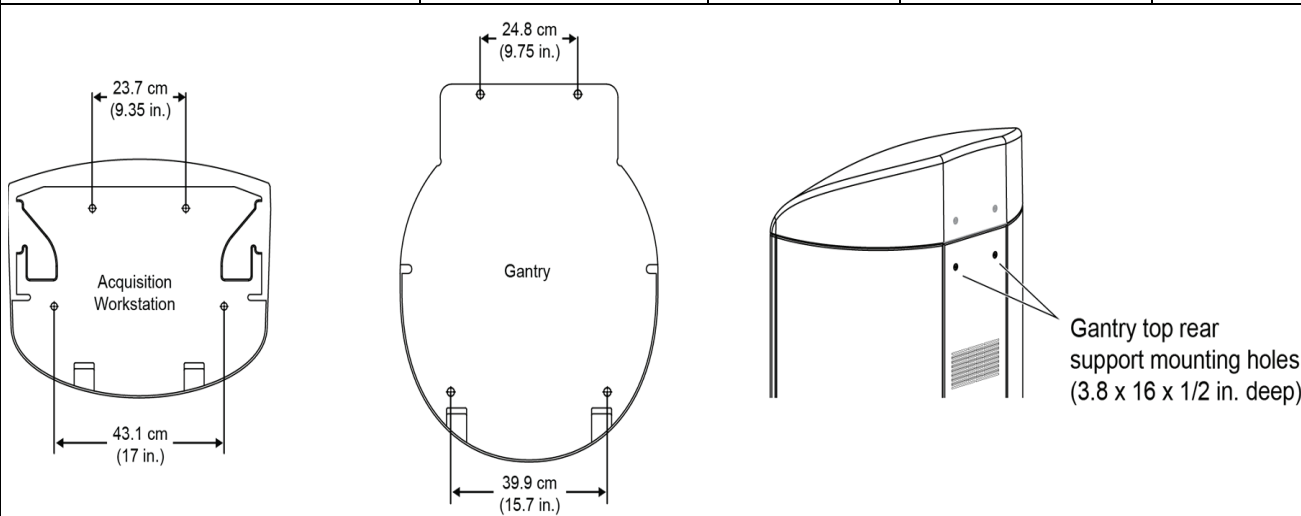

**Notes:** The mounting diagrams provided in this document are recommendations only; the final responsibility for proper installation belongs to the Installation Coordinator. Ensure all installations meet local regulations. A set of full-size mounting/drilling paper templates for the Gantry and AWS are available (Part Numbers RD-00916 and RD-00917).

Additional Notes		
Note #	Topic	Notes

**This page is intentionally left blank.**

**Coach Planning Templates**

## Room Layout Worksheet

These templates can be used to establish a functional room layout.

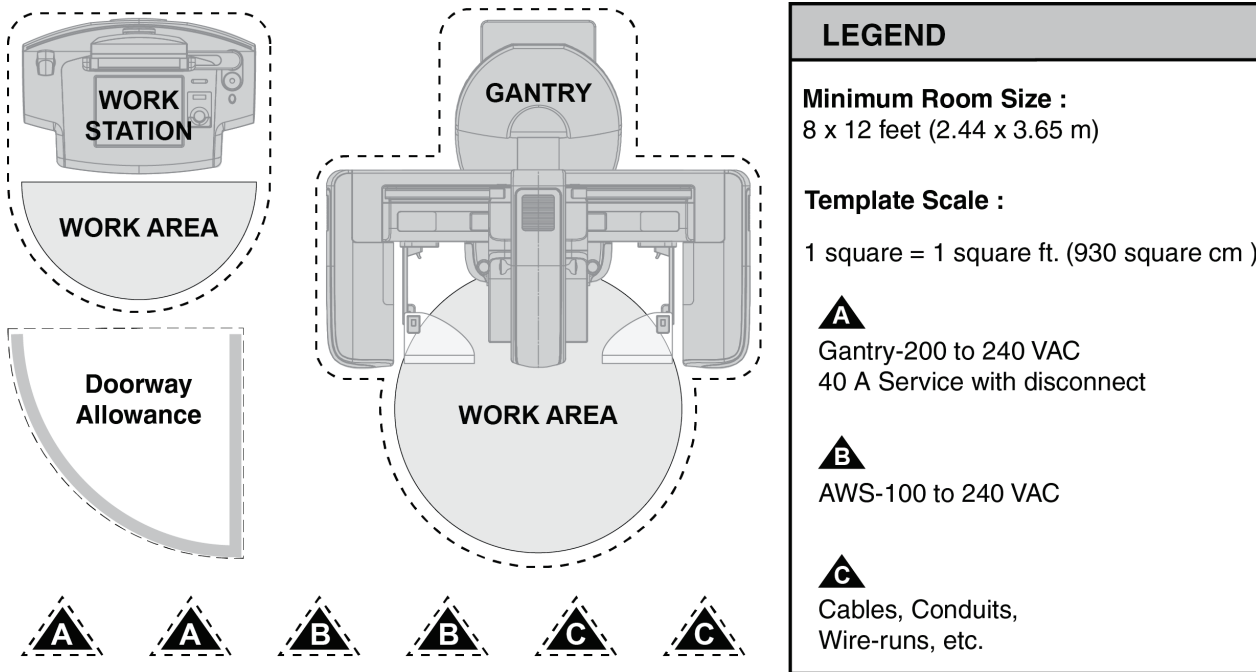

**Instructions:** Make copies of the grid and the system component cutouts. Outline the designated room size (to scale) on the grid, and then cut out the system components from the copy. Position the component cutouts on the grid to layout the desired work space.

Allow sufficient and convenient storage for accessories. Be sure to include access clearances for service personnel. Avoid areas that may hinder access to the equipment and patient. Also avoid equipment positioning near heat ducts or air-conditioning vents.

To protect from radiation exposure, locate the Acquisition Workstation so the radiation shield provides complete protection for the operator. If possible, include extra space and power outlets for future expansion of clinical services.





# HOLOGIC®



Hologic Inc.  
36-37 Apple Ridge Road  
Danbury, CT 06810 USA



Hologic NV  
Leuvensesteenweg 250A  
1800 Vilvoorde, Belgium  
Telephone: +32.2.711.4680

CE  
0044