



**Warning:**

To avoid injury, use mounting hardware suitable for the wall construction (not included).



**Warning:**

To avoid injury, follow the installation instructions included with the mounting hardware.



**Caution:**

The maximum load capacity is 100 pounds (45 kg).



**Caution:**

Be aware of C-arm clearance during rotation.



1.

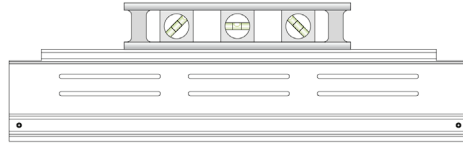

2.

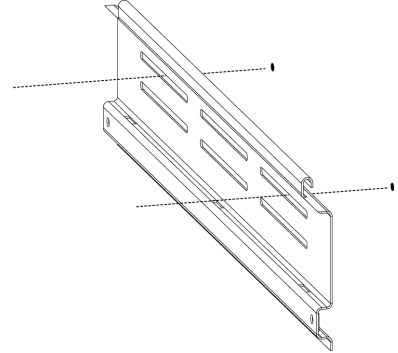

3.

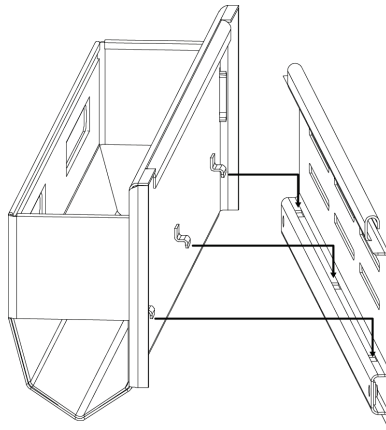

4.

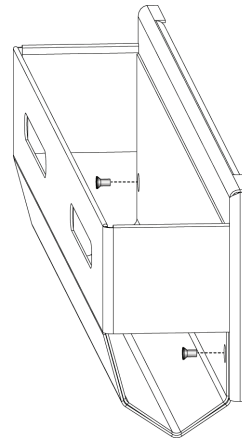

When more than one rack is installed, allow sufficient space between the racks.

