

SecurView®

Breast Imaging Workstation



SecurView DX Workstation Quality Control Manual

MAN-08919 Revision 003

HOLOGIC®

SecurView[®] DX

Breast Imaging Workstation

Quality Control Manual

For Software Version 11.1

Part Number MAN-08919

Revision 003

February 2024

HOLOGIC[®]

Product Support

USA: +1.877.371.4372
Europe: +32 2 711 4690
Asia: +852 37487700
Australia: +1 800 264 073
All Other: +1 781 999 7750
Email: BreastHealth.Support@hologic.com

© 2022-2024 Hologic, Inc. Printed in the USA. This manual was originally written in English.

Hologic, Dimensions, SecurView, Selenia, and associated logos are trademarks and/or registered trademarks of Hologic, Inc., and/or its subsidiaries in the United States and/or other countries. All other trademarks, registered trademarks, and product names are the property of their respective owners.

This product may be protected by one or more U.S. or foreign patents as identified at www.Hologic.com/patent-information.



Softcopy reading software © 2002–2021 MeVis Medical Solutions AG. All rights reserved. This product and related documentation are protected by copyright and are distributed under licenses restricting their use, copying, distribution, and decompilation. No part of this product or related documentation may be reproduced in any form by any means without prior written authorization of MeVis Medical Solutions AG and its licensors, if any. FlowBack, FlowNext, MammoNavigator, and ReportFlow are trademarks of MeVis BreastCare GmbH & Co. KG. This product may be protected by one or more of the following patents: 7,283,857, 6,891,920.

Libraries

ABYSS Web Server – Copyright © 2000 by Moez Mahfoudh <mmoez@bigfoot.com>. All rights reserved. Libtiff library © 1988-1997 Sam Leffler, 1991-1997 Silicon Graphics, Inc. OFFIS_DCMTK © 1994–2005, OFFIS MergeCOM-3 Advanced Integrator's Tool Kit PostgreSQL © 1996-2018, The PostgreSQL Global Development Group, © 1994, The Regents of the University of California. Jpeglib © 1991-1998, Thomas G. Lane xerces © 1999-2010 The Apache Software Foundation 7-Zip © 1999-2009 Igor Pavlov. Qt © 2014 Digia Plc and/or its subsidiary(-ies), licensed under LGPL v2.1. This Qt library has been adapted by MeVis Medical Solutions AG. You may obtain the complete corresponding source code by sending an order to MeVis Medical Solutions AG, Support Department, Caroline-Herschel-Str. 1, 28359 Bremen, Germany. XML-RPC – Copyright © 2001 by First Peer, Inc. All rights reserved. Copyright © 2001 by Eric Kidd. All rights reserved.

Table of Contents

List of Figures	vii
List of Tables	ix
1: Introduction	1
1.1 Descriptions of Warnings, Cautions, and Notes	1
1.2 Safety	2
1.3 Product Complaints.....	2
1.4 Terms and Definitions.....	3
2: QC Activities for the Medical Physicist	5
2.1 QC Procedures for the Medical Physicist	6
2.2 Corrective Action.....	7
2.3 Reading Room Configuration Testing	7
3: QC Activities for the Radiologic Technologist	9
3.1 QC Procedures for the Radiologic Technologist.....	10
3.2 Corrective Action.....	11
4: Testing the Displays	13
4.1 Testing Built-in Photometer Sensor Displays	14
4.2 Testing External Photometer Sensor Displays.....	19
4.3 Testing Displays with QAWeb Enterprise	26
5: Calibrating the Displays	29
6: Additional Procedures	31
6.1 Saving the Medical QAWeb Action History	31
6.2 Scheduling the Hologic Compliance Test.....	33
Appendix A SecurView Annual QC Form for Medical Physicists	35
Appendix B SecurView Weekly QC Form for Radiologic Technologists	37
Appendix C Running Barco Coronis Uniti Auto-calibration Manually	39

List of Figures

Figure 1: MediCal QAWeb Agent Window	15
Figure 2: Workstation > Status Window	15
Figure 3: Hologic Compliance Test Window	16
Figure 4: Hologic Compliance Test – View Detailed Result Window	17
Figure 5: Hologic Compliance Test Window	18
Figure 6: Hologic Compliance Test – View Detailed Result Window	18
Figure 7: Barco Photometer Sensor and Felt Pad Attachment (previous model)	19
Figure 8: Barco Photometer Sensor (new model)	19
Figure 9: Using a Photometer to Calibrate the Display	20
Figure 10: Removing the Suction Cup and Installing the Felt Pad	21
Figure 11: MediCal QAWeb Agent Window	22
Figure 12: Workstation > Status Window	22
Figure 13: Hologic Compliance Test Window	23
Figure 14: Hologic Compliance Test – View Detailed Result Window	24
Figure 15: Hologic Compliance Test Window	25
Figure 16: Hologic Compliance Test – View Detailed Result Window	25
Figure 17: Mammography Compliance Report	27
Figure 18: Mammography Constancy Test	28
Figure 19: Workstation > Status window	29
Figure 20: Auto-Calibration Window	30
Figure 21: Action History Window	32

List of Tables

Table 1: Terms and Definitions	3
Table 2: Annual QC Form for Medical Physicists	35
Table 3: Performance Criteria.....	35
Table 4: Weekly QC Form for Radiologic Technologists.....	37

Chapter 1 Introduction

This manual provides procedures developed to ensure the consistency of the brightness, contrast, and image presentation of the displays used with Hologic’s SecurView diagnostic review workstations.

Use the procedures and quality control (QC) forms in this manual to maintain an effective QC program that conforms to the rules of the United States Mammography Quality Standards Act (MQSA) or to become accredited by an accreditation body. This manual may also be used as a guide by facilities outside the United States to establish a QC program to conform to the applicable local standard acts and regulations. This manual is intended for use by Radiologic Technologists and Medical Physicists who are qualified to operate the SecurView system.

1.1 Descriptions of Warnings, Cautions, and Notes

Descriptions of Warnings, Cautions, and Notes used in this manual:



WARNING!

The procedures that you must follow accurately to prevent possible dangerous or fatal injury.



Warning:

The procedures that you must follow accurately to prevent injury.



Caution:

The procedures that you must follow accurately to prevent damage to equipment, loss of data, or damage to files in software applications.



Note

Notes show additional information.

1.2 Safety

Observe all electrical, mechanical, and radiation safety standards.



Caution:

Always obey Electrostatic Discharge (ESD) precautions when working with electronics and electronic components.



Note

It is recommended that you read through this document fully before starting to work.



Note

The Service Engineers must complete Hologic training courses before they operate or service a system.

1.3 Product Complaints

Any healthcare professional who has complaints or is dissatisfied with the quality, durability, reliability, safety, effectiveness, and/or performance of this product should notify Hologic.

If the device malfunctions and may have caused or contributed to a serious injury of a patient, notify Hologic immediately by telephone, fax, or written correspondence.

1.4 Terms and Definitions

Table 1: Terms and Definitions

Terms	Definitions
cd/m ²	Candela per square meter (cd/m ²), the standard unit of luminance. It represents a luminous intensity of one candela radiating from a surface whose area is one square meter. Luminance is used to specify the brightness of computer displays.
DICOM	Digital Imaging and Communications in Medicine – an international standard for the exchange of imaging and related information.
GSDF	Grayscale Standard Display Function, a mathematical function that adjusts pixel brightness in order to compensate for the nonlinearity of human visual perception. DICOM GSDF improves conspicuity of findings in the extremes of luminance and provides a mechanism to standardize the appearance of images on displays of different inherent brightness and with different response curves.
LCD	Liquid Crystal Display. The technology used for displays in notebook and other computers. Like light-emitting diode (LED) technology, LCDs allow displays to be much thinner than cathode ray tube (CRT) technology.
Luminance	Luminance is a photometric measure of the luminous intensity per unit area of light travelling in a given direction. It describes the amount of light that passes through or is emitted from a particular area, and falls within a given solid angle. The International System of Units (SI) for luminance is candela per square meter (cd/m ²).
MQSA	Mammography Quality Standards Act. Created by the U.S. Food and Drug Administration (FDA) and approved by the U.S. Congress in 1994, MQSA establishes quality standards for mammography facilities. MQSA requires mammography facilities to be accredited by the FDA or an FDA-approved accreditation body, be certified by the FDA or the State, receive annual MQSA inspections, and display its FDA certification in a prominent area.
QA	Quality Assurance. Generally used to describe a program of policies, procedures, and practices intended to assure that quality standards are developed, maintained, and adhered to.
QC	Quality Control. Refers to one or more procedures intended to ensure that a manufactured product or performed service complies with a defined set of quality criteria and meets the requirements of the client or customer.
USB	Universal Serial Bus. A specification to establish communication between devices and a host controller such as a computer. This interface can connect a computer and add-on devices, such as media players, keyboards, flash drives, and printers.

Chapter 2 QC Activities for the Medical Physicist

Hologic provides QC software (MediCal QAWeb) that is used by service engineers and customers to establish and maintain the operating levels of the SecurView displays. The software analyzes the results of display calibration and compliance testing and indicates whether the displays meet the pre-programmed QC limits established by the manufacturer.



Caution:

Connecting a QAWeb agent to a QAWeb server may overwrite the required Hologic Policy Map. When connecting to a QAWeb server contact Technical Support at +1.800.760.8342 to obtain the correct version of QAWeb that will maintain the required Hologic Policy Map.

During SecurView system installation, a service engineer uses the software to calibrate the displays. After installation, Radiologic Technologists use the software for the following two tests:

- **Weekly:** The Hologic Compliance Test verifies that the displays are performing within the preprogrammed limits. The Technologist records the results in the SecurView Weekly QC Form.
 - **Semi-Annual Auto-Calibration:** The MediCal QAWeb software calibrates the displays twice a year to re-establish the operating levels. The Technologist records the results in the SecurView Weekly QC Form.
-

**Note**

For the Barco Uniti™, High-Brightness, Coronis and Barco Nio MDNG-5221 displays, the MediCal QAWeb software runs the tests automatically. For the Barco Nio MDNG-6121 and MDNG-5121 displays, the Technologist must use a photometer and run the tests manually as explained in chapter [Calibrating the displays](#) on page 29.

In addition, Hologic recommends to use MediCal QAWeb software for the following test:

- **Annually:** The Medical Physicist checks the most recent results of the Hologic Compliance Test and records them in the SecurView Annual QC Forms. Refer to section [Appendix A: SecurView Annual QC Form for Medical Physicists](#) on page 35.
-

**Note**

When displays are replaced or relocated the Medical Physicist needs to perform the Hologic Compliance Test results check.

2.1 QC Procedures for the Medical Physicist

Hologic recommends that a Medical Physicist check the performance of each SecurView diagnostic workstation display at least once a year using the procedure given below. Use the display QC software (MediCal QAWeb) provided with each SecurView workstation. For detailed instructions on using the software, refer to chapter [Testing the Displays](#) on page [13](#).

To run the annual QC check, do the following steps:

1. **Check performance records.** For each diagnostic workstation, review the [Appendix B: SecurView Weekly QC Form for Radiologic Technologists](#) on page [37](#). Verify that the SecurView displays have been operating within the recommended tolerance limits.
2. **Review Hologic Compliance Test results.** Using the QC software, check the results of the most recent Hologic Compliance Test. If the test has not been run during the last week, then run the test.
3. **Verify results.** Ensure the Hologic Compliance Test results are within the recommended tolerance limits.
 - a. For each display, check:
 - White level
 - DICOM GSDF compliance (Luminance Response).
 - b. If the results do not meet specifications, refer to section [Corrective Action](#) on page [Z](#).
4. **Record the results** in the following form(s):
 - [Appendix A: SecurView Annual QC Form for Medical Physicists](#) on page [35](#)
 - [Appendix B: SecurView Weekly QC Form for Radiologic Technologists](#) on page [37](#)
5. For Selenia Dimensions systems:
 - a. At the *Acquisition Workstation*, select **Admin > Quality Control > Physicist tab > Diagnostic Review Workstation Quality Control**.
 - b. Select **Mark Completed**, to label the status of this procedure as finished.
 - c. To mark the QC procedure as completed, select **Yes**.

2.2 Corrective Action

If any display does not meet the performance criteria, adjust room lighting conditions and repeat the action that failed. If the action fails after the *second* attempt, correct the problem before performing mammographic image interpretation using the instructions below:

If any performance criterion is not met, use the Auto-calibration procedure to recalibrate the display. Then rerun the Hologic Compliance Test and verify that the display performs within the recommended limits.

A qualified service engineer may have to resolve any issues if display operating levels are not within recommended ranges.

If the details of a test contain no results, the test shall be run manually after making sure the displays are correctly attached and turned on. A qualified service engineer may have to resolve any issues if the details of a test contain no results after the second attempt.

While you resolve display calibration issues, SecurView systems can still receive images. Use an alternative diagnostic device (for example, a second diagnostic workstation or DICOM printer) for mammography image interpretation until all issues are resolved and the displays perform within recommended ranges.

2.3 Reading Room Configuration Testing

A qualified in-person Medical Physicist performs testing when a reading room is initially configured, and after each year of operation. If equipment is replaced between these scheduled tests without changing the reading room configuration, this replacement does not require in-person Medical Physicist testing and is subject to the Medical Physicist's oversight.

At the suggestion of the Lead Interpreting Physician, the Medical Physicist may set White Level to be other than the default shown in the Performance Criteria table in [Appendix A: SecurView Annual QC Form for Medical Physicists](#) on page 35.

Chapter 3 QC Activities for the Radiologic Technologist

Hologic provides QC software (MediCal QAWeb or QAWeb Enterprise) that is used by the Radiologic Technologist to maintain the operating levels of the SecurView displays. The software analyzes the results of display calibration and compliance testing and indicates whether the displays meet the pre-programmed QC limits established by the manufacturer.



Caution:

Connecting a QAWeb agent to a QAWeb server may overwrite the required Hologic Policy Map. When connecting to a QAWeb server contact Technical Support at +1.800.760.8342 to obtain the correct version of QAWeb that will maintain the required Hologic Policy Map.

During SecurView system installation, a service engineer uses the software to calibrate the displays. After installation, Radiologic Technologists use the software for the following two tests:

- **Weekly:** The Hologic Compliance Test verifies that the displays are performing within the preprogrammed limits. The Technologist records the results in the SecurView Weekly QC Form.
- **Semi-Annual Auto-Calibration:** The MediCal QAWeb software calibrates the displays twice a year to re-establish the operating levels. The Technologist records the results in the SecurView Weekly QC Form.



Note

For the Barco Uniti, High-Brightness, Coronis and Barco Nio MDNG-5221 displays, the MediCal QAWeb software runs the tests automatically. For the Barco Nio MDNG-6121 and MDNG-5121 displays, the Technologist must use a photometer and run the tests manually as explained in chapter [Calibrating the displays](#) on page [29](#).

3.1 QC Procedures for the Radiologic Technologist

Hologic recommends that a Radiologic Technologist check the performance of SecurView diagnostic workstation displays using the procedures given below. Use the QC software (MediCal QAWeb or QAWeb Enterprise) provided with each workstation. For detailed instructions on using the software, refer to chapter [Testing the Displays](#) on page [13](#).

To run the weekly QC check:

1. Run the **Hologic Compliance Test**.



Note

For displays that support scheduled Hologic Compliance Tests, verify successful completion of the tests the morning after the scheduled Hologic Compliance Tests occur. If the system failed one or more of the tests, the source of the problem must be identified and corrective action taken before the system is used for clinical purposes. Refer to section [Corrective Action](#) on page [11](#).

- For the Barco Uniti, High-Brightness, Coronis and Barco Nio MDNG-5221 displays, MediCal QAWeb automatically runs the Hologic Compliance Test once a week. Verify that the test ran as scheduled and the Status displayed is OK.
 - For Barco Nio MDNG-6121 and MDNG-5121 displays, MediCal QAWeb prompts you to run the Hologic Compliance Test once a week. Run the test with the photometer and, when done, verify that the Action Result displayed is OK.
 - When the QC Check is done, verify that *Result: OK* displays.
 - If results are not OK, refer to section [Corrective Action](#) on page [11](#).
2. Record the results in the [Appendix B: SecurView Weekly QC Form for Radiologic Technologists](#) on page [37](#).



Note

Hologic strongly recommends saving the MediCal QAWeb Action History monthly to prevent data loss in the event of a system failure. Hologic also recommends saving the Action History prior to a SecurView upgrade. Refer to section [Saving the MediCal QAWeb Action History](#) on page [31](#).

To run the semi-annual calibration:

1. If the displays have not been calibrated during the last six months, use the QC software (Auto-calibration) to calibrate them.
2. Record the results in the [Appendix B: SecurView Weekly QC Form for Radiologic Technologists](#) on page [37](#).

After completing the QC procedure, do the following for Selenia Dimensions systems only:

1. At the Acquisition Workstation, select **Admin > Quality Control > Technologist tab > Diagnostic Review Workstation Quality Control**.
2. Select **Mark Completed**, to label the status of this procedure as finished.
3. To mark the QC procedure as completed, select **Yes**.

3.2 Corrective Action

If any display does not meet the performance criteria, adjust room lighting conditions and repeat the action that failed. If the action fails after the second attempt, correct the problem before performing mammographic image interpretation using the instructions below.

If any performance criterion is not met, use the Auto-calibration procedure to recalibrate the display. Then rerun the Hologic Compliance Test and verify that the display performs within the recommended limits.

A qualified service engineer may have to resolve any issues if display operating levels are not within recommended ranges.

If the details of a test contain no results, the test shall be run manually after making sure the displays are correctly attached and turned on. A qualified service engineer may have to resolve any issues if the details of a test contain no results after the second attempt.

While you resolve display calibration issues, SecurView systems can still receive images. Use an alternative diagnostic device (for example, a second diagnostic workstation or DICOM printer) for mammography image interpretation until all issues are resolved and the displays perform within recommended ranges.

Chapter 4 Testing the Displays

There are two different QA software packages that can be used with these displays. The newer QAWeb Enterprise can be used with the following displays. This chapter provides detailed QC procedures for the various displays.

Display	Barco Model Number
Coronis Uniti	MDMC-12133
Nio 5.8 MP Color Display	MDNC-6121
High-Brightness	MDMG-5221
Coronis	MDCG-10130 MDMG-5121 MFGD-5621 HD MFGD-5421
Nio	MDNG-6121 MDNG-5121 MDNG-5221

There are two types of display configurations:

- **Built-in photometer sensor displays - Barco Uniti, High-Brightness, Coronis, and Barco Nio MDNG-5221:** The MediCal QAWeb software automatically runs the Hologic Compliance Test and calibrates the Barco displays on a scheduled basis. The QAWeb software relies on a built-in photometer sensor. No user intervention is required, you only need to verify that the software ran the test as scheduled and that the results were within the tolerance ranges. The default scheduled time is between 12:00 midnight and 2:00 AM.
- **External photometer sensor displays - Barco Nio (MDNG-6121 and MDNG-5121):** The MediCal QAWeb software automatically alerts you to run the Hologic Compliance Test and calibrate these Barco Nio displays on a scheduled basis. You will use an external photometer to run the QC procedures.



Important

When testing the displays, ensure that the room lighting conditions are similar to those used when reading studies.

4.1 Testing Built-in Photometer Sensor Displays

For built-in photometer sensor displays, MediCal QAWeb automatically runs the Hologic Compliance Test once a week and the Auto-calibration routine twice a year. Use this procedure as follows:

- **Radiologic Technologist:** Verify that the test(s) ran successfully.
- **Medical Physicist:** Review and record the numerical results from the most recent Hologic Compliance Test.



Note

Hologic recommends for displays older than five years that the Medical Physicist use an external photometer once a year for the luminance check to confirm the internal photometer is still operating correctly. The luminance measured by the photometer must be within 15% of the calibrated luminance. The calibrated luminance for each display can be found in the configuration of QAWeb Agent or in the most recent compliance check results in the status.

To check the performance of Barco displays:

1. Log out any user from the SecurView DX application.
2. To start MediCal QAWeb, press the **Windows**  key, then select **Programs > Barco > MediCal QAWeb Agent**.



Note (Windows XP users):

After logging out of SecurView, the Windows key is sometimes not active, which prevents users from manually starting up the MediCal QAWeb software. In such a situation, start MediCal QAWeb as follows:

- a. Log into SecurView as an Administrator user, then select the **Exit to Windows** tab.
- b. From the Windows desktop, double-click the **MediCal QAWeb** icon (or select **Start > Programs > Barco > MediCal QAWeb Agent**).
- c. From the main MediCal QAWeb window, select **Switch User**.
- d. Log into MediCal QAWeb as the **Advanced** user with the password 'advanced' (case-sensitive).

3. The *MediCal QAWeb Agent* window opens. Select the **Status** icon.

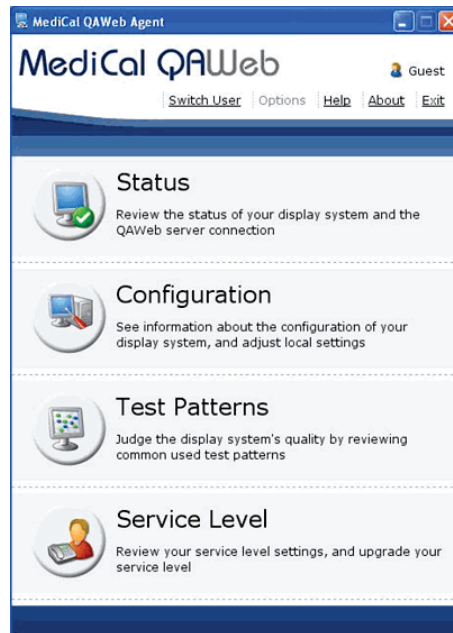

Figure 1: MediCal QAWeb Agent Window

4. The *Workstation > Status* window opens:

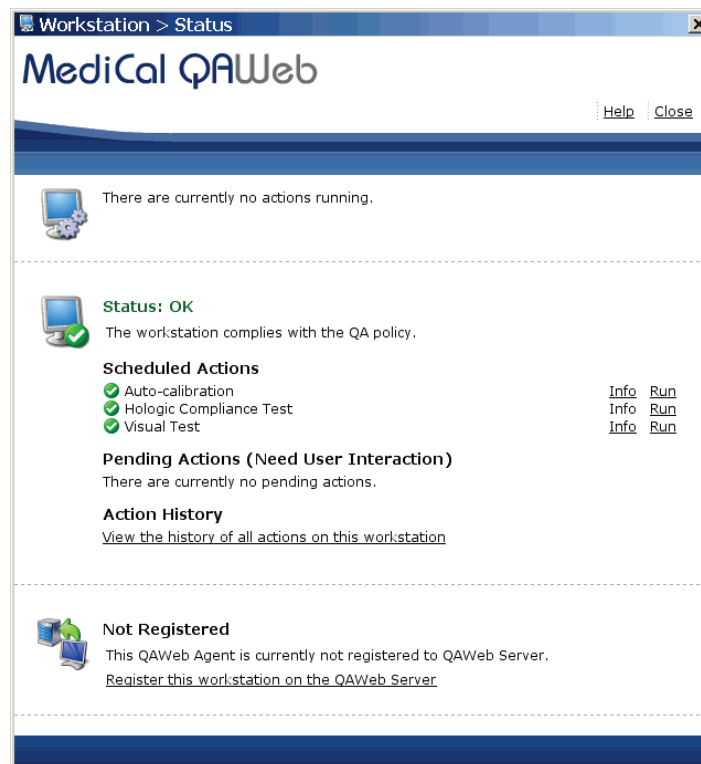

Figure 2: Workstation > Status Window

The *Workstation > Status* window indicates whether the workstation meets the recommended performance criteria. At any time, you can select **Run** to run a test manually (Auto-calibration, Hologic Compliance Test, or Visual Test).



Note

Manually calibrating the Uniti display with SteadyColor Calibration will show colors in the most optimum and consistent way, and all grayscales with as little hue variation as possible. To manually calibrate the Uniti display with SteadyColor Calibration, refer to [Appendix C: Running Barco Coronis Uniti Auto-calibration Manually](#) on page 39.



Note

To manually calibrate the Uniti display without SteadyColor Calibration, navigate to **Configuration > Calibration**, select **Calibrate**, type the password **advanced** (case sensitive), select **Advanced**, then deselect **SteadyColor Calibration**. Select **Calibrate**.



Note

When you manually run the Auto-calibration Test, you may be prompted for a password. By default, the password is 'advanced' (case sensitive).

5. **Radiologic Technologist** – To complete the tests and view results:
 - a. Verify that *Status: OK* displays.
 - b. Select **Info** next to 'Hologic Compliance Test'. The most recent results for the test display.
 - c. Verify that *Action Result: OK* displays.



Figure 3: Hologic Compliance Test Window

- d. Select **View Detailed Result**. A window opens with the detailed results.

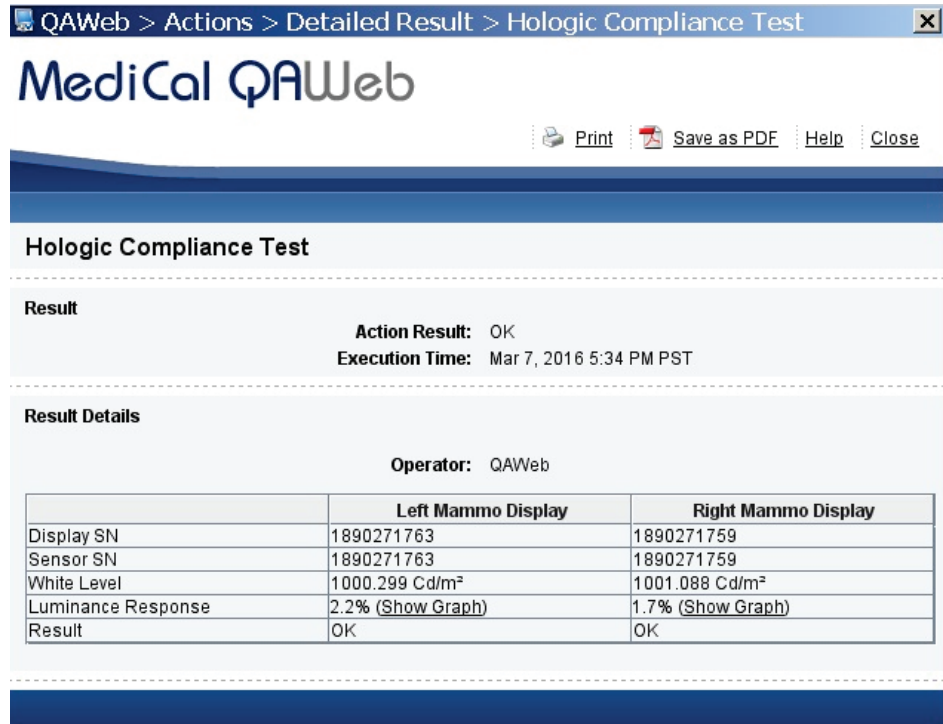

Figure 4: Hologic Compliance Test – View Detailed Result Window

- e. Record the value for **Action Result** in [Appendix B: SecurView Weekly QC Form for Radiologic Technologists](#) on page 37.



Important

If the details of a test contain no results, follow the instructions in section [Corrective Action](#) on page 11.



Note

You may **Print** the results or **Save as PDF** for a local copy from this window. Select **Close** once you are finished.

- f. Select **Close** to return to the *Hologic Compliance Test* window.
 g. Close all open *MediCal QAWeb* windows.

6. **Medical Physicist** – To view the numerical results of the Hologic Compliance Test:
 - a. On the *Workstation > Status* window, select **Info** next to 'Hologic Compliance Test'. The most recent results for the test display as shown in the following example.



Figure 5: Hologic Compliance Test Window

- b. Select **View Detailed Result**. A window opens with the detailed results.

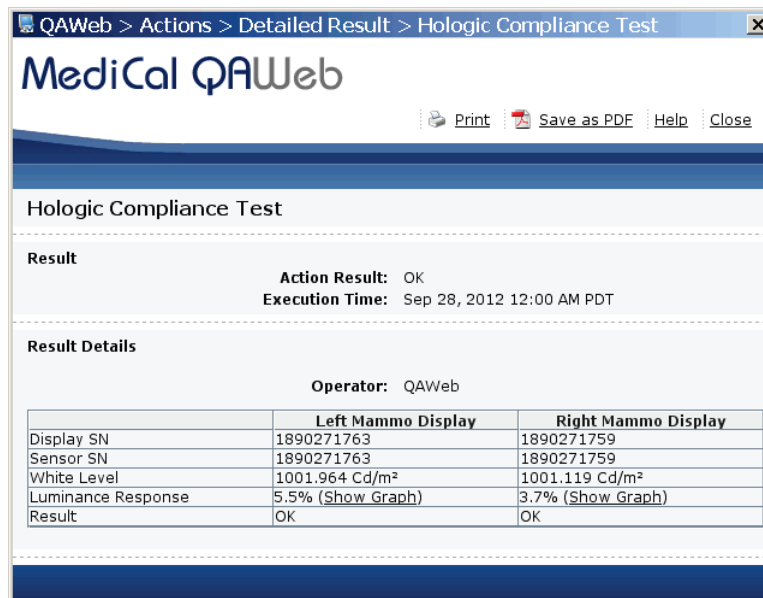

Figure 6: Hologic Compliance Test – View Detailed Result Window

- c. Verify that the results meet the performance criteria.
- d. Record the results in the [Appendix A: SecurView Annual QC Form for Medical Physicists](#) on page 35.
- e. Select **Close** twice, to return to the *Workstation > Status* window.
- f. Close all open *MediCal QAWeb* windows.

4.2 Testing External Photometer Sensor Displays

For external photometer sensor displays, MediCal QAWeb alerts you to run the Hologic Compliance Test once a week and the Auto-calibration procedure (refer to chapter [Calibrating the displays](#) on page 29) twice a year. Use the procedure in this section as follows:

- **Radiologic Technologist:** Run the QC tests and verify that they ran successfully.
- **Medical Physicist:** Review and record the numerical results from the most recent Hologic Compliance Test.

To calibrate the displays, users must have an external photometer as shown below.

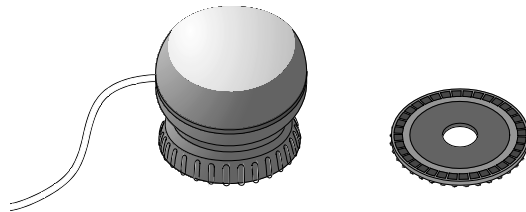

Figure 7: Barco Photometer Sensor and Felt Pad Attachment (previous model)



Figure 8: Barco Photometer Sensor (new model)

When performing these test procedures, note the following:

- Verify that the Barco USB Photometer is plugged into the same USB port in which it was originally installed. If the sensor was removed for any reason, reconnect it as explained on the next page before continuing (Refer to **Reconnecting the Photometer Sensor** on the next page).
- Verify that the felt pad is attached to the photometer sensor. If the felt pad is not attached, reconnect it as explained on the next page before continuing (Refer to **Attaching the Felt Pad to the Photometer Sensor** on page 19).
- The new model of the sensor does not have a felt pad attachment. Verify that the photometer sensor is open by flipping the cover.



Note

The only difference between the previous model and the new model of the Photometer Sensor is that the new model does not have the felt pad attachment. All other functions are similar.

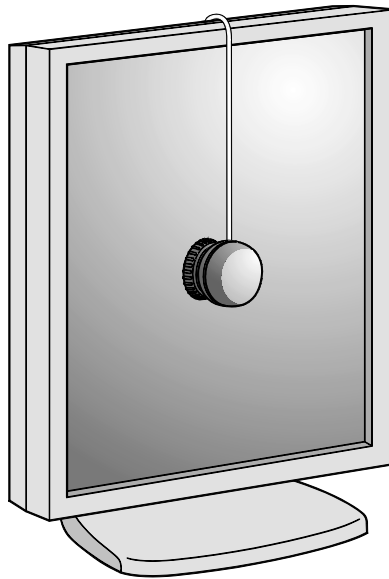

Figure 9: Using a Photometer to Calibrate the Display

Reconnecting the Photometer Sensor

The Barco photometer sensor is USB-port-specific and does not function if inserted into a different USB port than the one originally used when installed. After installation, there should be no need to remove the sensor from the original USB port. If the photometer is not connected to its USB port, then reconnect it as described here.

1. Log into Windows as Administrator.
2. Plug the Barco photometer sensor into an open USB port.
 - If a log-in prompt asks you to log into an account that is part of the Administrators group, select **Cancel**, then try a different USB port. When you plug into the correctly configured port, the system will not prompt you to log into another account.
 - If a *Found New Hardware Wizard* window opens after connecting the photometer sensor, select **Cancel**, then try a different USB port. When you plug into the correctly configured port, a *Found New Hardware Wizard* window should not open.
3. If you cannot find the correct USB port, contact Technical Support at +1.800.760.8342.



Note

The new model of the Photometer Sensor does not have a felt pad. The instructions to attach the felt pad to the Photometer Sensor apply only to previous model.

Attaching the Felt Pad to the Photometer Sensor

The felt pad attachment is included with the display calibration kit. If you need to reconnect the felt pad, follow the instructions below.

1. If the suction cup attachment is installed, remove by turning it approximately one-quarter turn counter-clockwise and then separating the attachment from the main portion of the photometer.

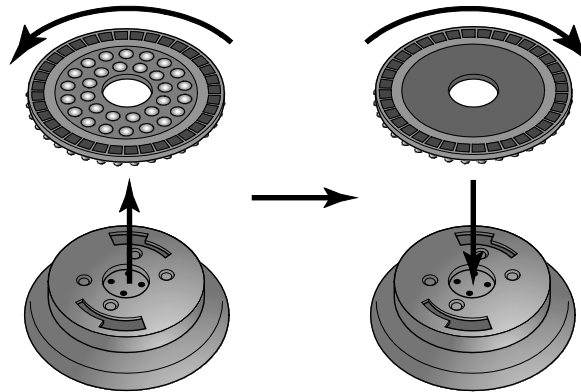

Figure 10: Removing the Suction Cup and Installing the Felt Pad

2. Install the felt pad by attaching it to the main portion of the photometer and turning it approximately one-quarter turn clockwise.

To test the displays:

1. Log out any user from the SecurView DX application.
2. To start MediCal QAWeb, press the **Windows**  key, then select **Programs > Barco > MediCal QAWeb Agent**.



Note (Windows XP users):

After logging out of SecurView, the Windows key is sometimes not active, which prevents users from manually starting up the MediCal QAWeb software. In such a situation, start MediCal QAWeb as follows:

- a. Log into SecurView as an Administrator user, then select the **Exit to Windows** tab.
- b. From the Windows desktop, double-click the **MediCal QAWeb** icon (or select **Start > Programs > Barco > MediCal QAWeb Agent**).
- c. From the main MediCal QAWeb window, select **Switch User**.
- d. Log into MediCal QAWeb as the **Advanced** user with the password 'advanced' (case-sensitive).

3. The *MediCal QAWeb Agent* window opens. Select the **Status** icon.

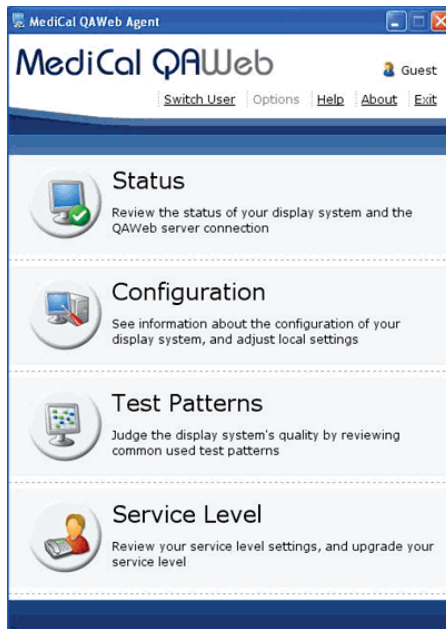

Figure 11: MediCal QAWeb Agent Window

4. The *Workstation > Status* window opens:

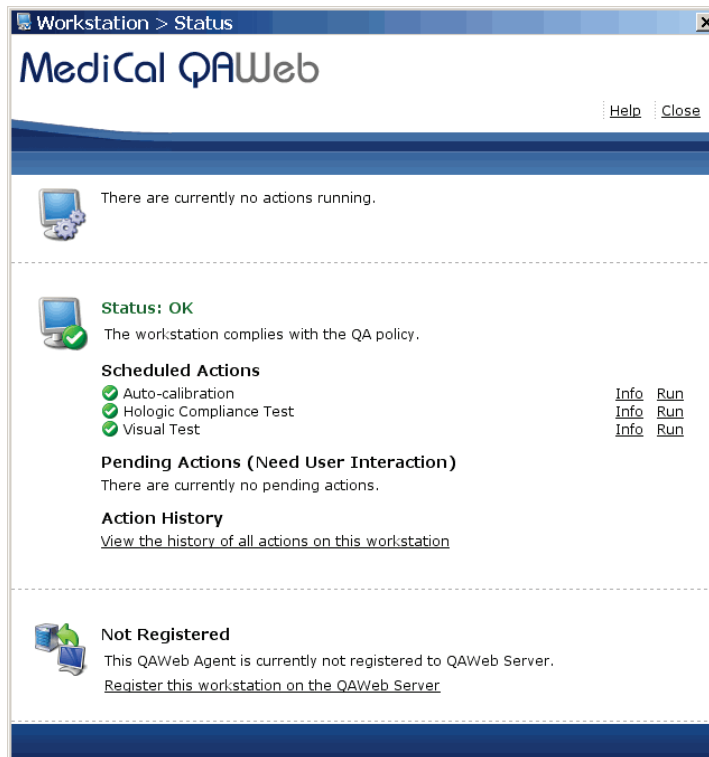

Figure 12: Workstation > Status Window

The *Workstation > Status* window indicates whether the displays meet the recommended performance criteria. At any time, you can select **Run** to run a test manually (Auto-calibration, Hologic Compliance Test, or Visual Test).



Note

When you manually run the Auto-calibration Test, you may be prompted for a password. By default, the password is 'advanced' (case-sensitive).

5. **Radiologic Technologist** – To run the Hologic Compliance Test and view results:



Important

When testing the displays, ensure that the room lighting conditions are similar to those used when reading studies.

- a. Select **Run** next to 'Hologic Compliance Test'. Follow the on-screen instructions.
- b. After the test ends, verify that *Status: OK* displays.
- c. Select **Info** next to 'Hologic Compliance Test'. The most recent results for the test display.
- d. Verify that *Action Result: OK* displays.

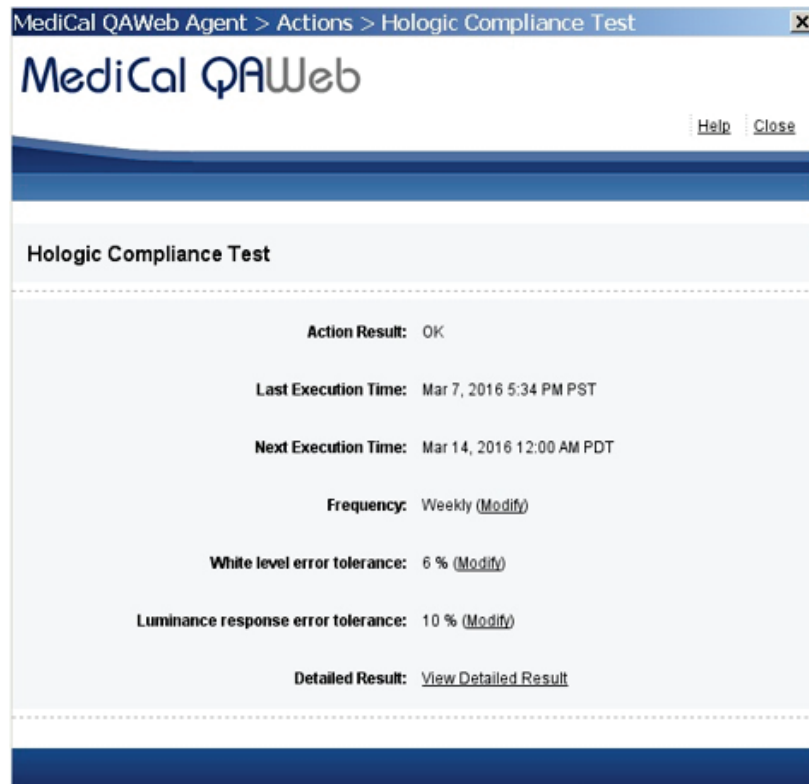

Figure 13: Hologic Compliance Test Window

- e. Select **View Detailed Result**. A window opens with the detailed results.

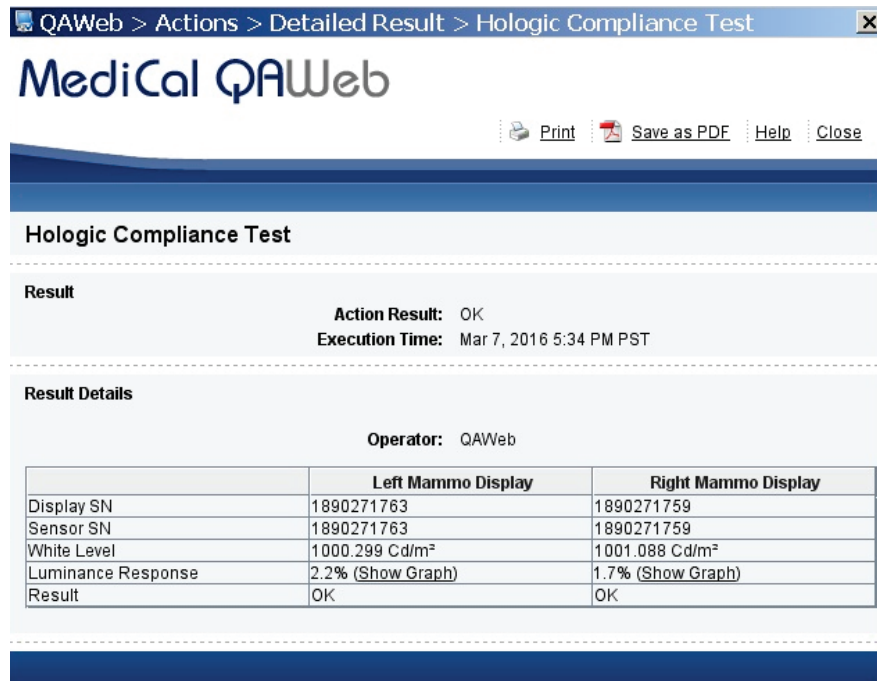

Figure 14: Hologic Compliance Test – View Detailed Result Window

- f. Record the value for **Action Result** in [Appendix B: SecurView Weekly QC Form for Radiologic Technologists](#) on page 37.



Important

If the details of a test contain no results, follow the instructions in section [Corrective Action](#) on page 11.



Note

You may **Print** the results or **Save as PDF** for a local copy from this window. Select **Close** once you are finished.

- g. Select **Close** to return to the *Hologic Compliance Test* window.
- h. Close all open *MediCal QAWeb* windows.

6. **Medical Physicist** – To view the numerical results of the Hologic Compliance Test:
 - a. On the *Workstation > Status* window, select **Info** next to ‘Hologic Compliance Test’. The most recent results for the test display as shown in the following example.



Figure 15: Hologic Compliance Test Window

- b. Select **View Detailed Result**. A window opens with the detailed results.

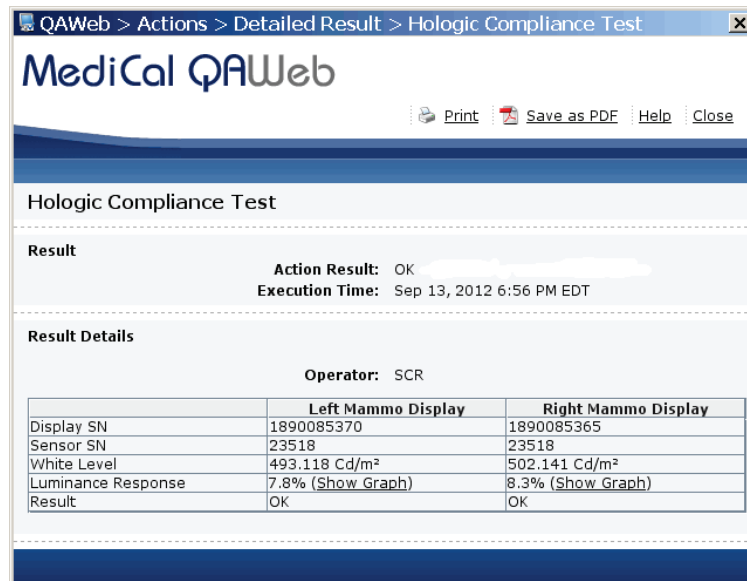

Figure 16: Hologic Compliance Test – View Detailed Result Window

- c. Verify that the results meet the performance criteria.
- d. Record the results in the [Appendix A: SecurView Annual QC Form for Medical Physicists](#) on page 35.
- e. Select **Close** twice, to return to the *Workstation > Status* window.
- f. Close all open *MediCal QAWeb* windows.

4.3 Testing Displays with QAWeb Enterprise

These displays all have built-in photometers. The QAWeb Enterprise software automatically runs the Mammography Compliance Task and calibrates the Barco displays on a scheduled basis. The QAWeb software relies on a built-in photometer sensor. No user intervention is required. You only need to verify that the software ran the test as scheduled and that the results were within the tolerance ranges. The default scheduled time is between 12:00 midnight and 2:00 AM.

For built-in photometer sensor displays, QAWeb Enterprise automatically runs the *Mammography constancy test* once a week and the *Calibration routine* twice a year. Use this procedure as follows:



- **Radiologic Technologist:** Verify that the test(s) ran successfully.
- **Medical Physicist:** Review and record the numerical results from the most recent Mammography constancy test.



Note

Hologic recommends for displays older than five years that the Medical Physicist use an external photometer once a year for the luminance check to confirm the internal photometer is still operating correctly. The luminance measured by the photometer must be within 15% of the calibrated luminance. The calibrated luminance for each display can be found in the active policy in the QAWeb Enterprise or in the most recent Mammography constancy test results.

To check the performance of Barco displays:

1. It is not necessary to logout any user from the SecurView DX application.
2. To access the QC test results in the QAWeb Enterprise software, use an internet browser to log in to <https://qaweb.healthcare.barco.com>.
 - a. Navigate to the workstation details.
 - b. Select the **Reports** tab, then select the  icon, then select the type of report to generate, Mammography Compliance Report.
 - c. Wait for the report icon to turn green .

d. Open the Mammography Compliance Report.

Mammography Compliance Report
 Workstation name: [mymammosystem.somehospital](#)
 Report creation: Jul/16/2020

Mammography acceptance test (latest)
 Tested mammography displays: Acceptance test result: > OK
 Display 1: Date & time: 06/23/20, 02:49 PM
 Serial: 2590069380 (MDNC-6121) Operator: Pieter
 Resolution (pixel format): 2096x2800 QAWeb Agent Version: 2.3
 Display 2:
 Serial: 2590069381 (MDNC-6121)
 Resolution (pixel format): 2096x2800

DICOM GSDF luminance response test

- Display 1: Max. deviation: 2% (limit: 10%)
- Display 2: Max. deviation: 3% (limit: 10%)

Calibrated white point luminance test

- Display 1: Measured L': 477.68 cd/m² (including Lamb 0.21 cd/m²). Deviation: 1% (limit: 5%)
- Display 2: Measured L': 489.71 cd/m² (including Lamb 0.21 cd/m²). Deviation: 1% (limit: 5%)

Visual test
 Pattern: TG18-OIQ

	Display 1	Display 2	Display 3	Display 4
All 16 luminance patches are visibly distinct?	<V> Yes	<V> Yes		
Evaluate the low contrast letters, masking of bright areas is permitted. The alphanumeric characters CONTRA appear sharply focused and the final I is detectable?	<V> Yes	<V> Yes		
Evaluate the overall appearance of the pattern. The pattern is free from non-uniformities and artefacts, especially at black-to-white and white-to-black transitions?	<V> Yes	<V> Yes		
In all four corners, both horizontally and vertically oriented high-contrast line-pair patterns representing the Nyquist limit for the display are distinguishable?	<V> Yes	<V> Yes		
In the center, both horizontally and vertically oriented high-contrast line-pair patterns representing the Nyquist limit for the display are distinguishable?	<V> Yes	<V> Yes		
The 5% patch is visible?	<V> Yes	<V> Yes		
The 95% patch is visible?	<V> Yes	<V> Yes		
The ramp bars appear continuous without any contour lines?	<V> Yes	<V> Yes		

Multi-display uniformity

- White point luminance deviation between displays: 1% (limit: 10%)

Page Break

Mammography constancy test history

Executed on	Result	Serial number	DICOM GSDF luminance response test	Calibrated white point luminance test	Luminance uniformity between displays
05/21/2020, 11:08 AM	✓	9385406679	✓ 5%	✓ 0%	✓ 0%
		9385406721	✓ 4%	✓ 1%	
05/22/2020, 11:34 AM	✓	9385406679	✓ 3%	✓ 1%	✓ 0%
		9385406721	✓ 4%	✓ 0%	

Figure 17: Mammography Compliance Report

e. Check that the latest Acceptance and Mammography constancy tests have a result of OK or green check mark. Check that details are present for these tests.

- f. Record the value for **Action Result** in [Appendix B: SecurView Weekly QC Form for Radiologic Technologists](#) on page 37.



Important

If the details of a test contain no results, follow the instructions in section [Corrective Action](#) on page 11.



Note

You may **Print** the results or **Save as PDF** for a local copy.

- g. Log out of the QAWeb Enterprise or close the browser tab once finished.
3. **Medical Physicist** – To view the numerical results of the Hologic Compliance Test:
4. Using an internet browser, log in to <https://qaweb.healthcare.barco.com>.
 - a. Navigate to the workstation details.
 - b. On the *Tasks* tab, select the **Mammography constancy test**.

Average target JND	Measured dL / L per JND	Target dL / L per JND	dL / L error
126.102	0.01634	0.01605	1.83%
161.086	0.01344	0.01362	-1.37%
196.07	0.01202	0.01197	0.45%
231.054	0.01074	0.01078	-0.41%
266.037	0.00986	0.0099	-0.39%
301.021	0.00917	0.00923	-0.56%
336.005	0.00868	0.0087	-0.18%
370.989	0.00827	0.00828	-0.15%
405.973	0.00802	0.00794	1.05%
440.956	0.00766	0.00767	-0.05%
475.94	0.00746	0.00744	0.24%

Figure 18: Mammography Constancy Test

- c. Verify that the results meet the performance criteria.
- d. Record the results in the [Appendix A: SecurView Annual QC Form for Medical Physicists](#) on page 35.
- e. Log out of the QAWeb Enterprise or close the browser tab once finished.

Chapter 5 Calibrating the Displays

Use this procedure:

- For manually calibrating the Barco Nio (MDNG-6121 and MDNG-5121) displays on a semi-annual basis. MediCal QAWeb automatically alerts the Radiologic Technologist when it is time to calibrate these Barco Nio displays.
- Whenever it is necessary to perform an unscheduled calibration.
 1. Log out any user from the SecurView DX application.
 2. Set up the displays and start MediCal QAWeb as described in chapter [Testing the Displays](#) on page [13](#).



Note

If you are calibrating external photometer sensor displays, attach the photometer sensor as described in section [Testing External Photometer Sensor Displays](#) on page [19](#).

3. From the *MediCal QAWeb Agent* window, select the **Status** icon. The *Workstation > Status* window opens.



Figure 19: Workstation > Status window

4. On the *Workstation > Status* window, select **Run** next to 'Auto-calibration'.



Note

When you manually run the Auto-calibration Test, you may be prompted for a password. By default, the password is 'advanced' (case sensitive).

5. Follow the on-screen instructions. Repeat for the second display. When the calibration procedure ends, the results display as shown in the example below. The check mark next to each display icon indicates that the calibration ran successfully.

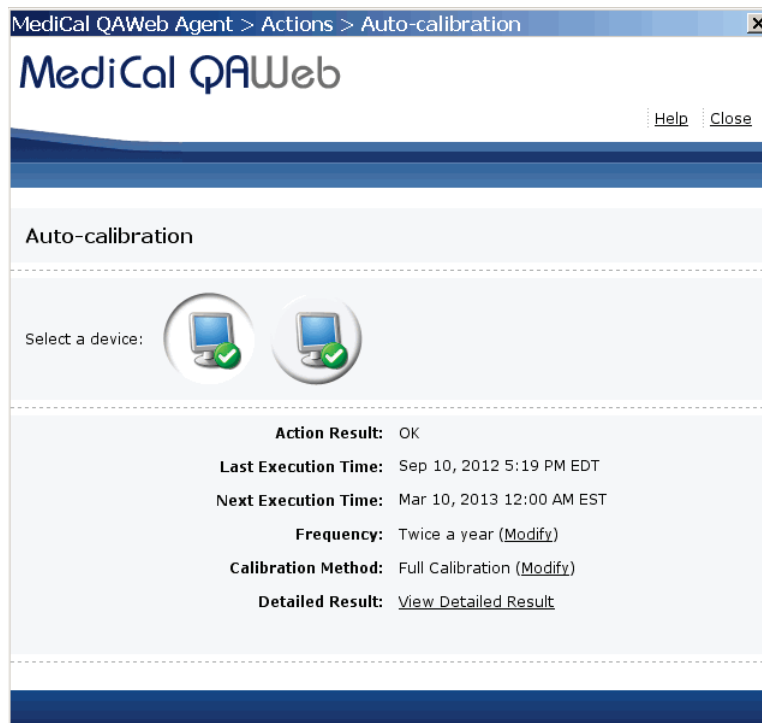

Figure 20: Auto-Calibration Window

6. Record the results in the [Appendix B: SecurView Weekly QC Form for Radiologic Technologists](#) on page 37.
7. Close all open *MediCal QAWeb* windows.



Note

The Next Execution Time for the Auto-calibration will be six months after the last day the test was manually run. It is important to continue monitoring the dates the tests are due for semi-annual documentation. The monitors may require calibration in between the six-month time frames if the Hologic Compliance Test fails.

Chapter 6 Additional Procedures

6.1 Saving the Medical QAWeb Action History

**Caution:**

Connecting a QAWeb agent to a QAWeb server may overwrite the required Hologic Policy Map. When connecting to a QAWeb server contact Technical Support at +1.800.760.8342 to obtain the correct version of QAWeb that will maintain the required Hologic Policy Map.

Hologic strongly recommends saving the MediCal QAWeb Action History monthly to prevent data loss in the event of a system failure. Hologic also recommends saving the Action History prior to a SecurView upgrade.

Printing the Action History provides a hardcopy record of all of the actions run on the SecurView workstation during a given month. Hologic recommends retaining the printed Action History as proof of compliance. Use the following procedure to save the Action History to a USB drive and then transfer it to a different computer for printing.

1. Log out any user from the SecurView DX application.
2. Insert a USB drive into the SecurView workstation.
3. To start MediCal QAWeb, press the **Windows**  key, then select **Programs > Barco > MediCal QAWeb Agent**.

**Note (Windows XP users):**

After logging out of SecurView, the Windows key is sometimes not active, which prevents users from manually starting up the MediCal QAWeb software. In such a situation, start MediCal QAWeb as follows:

- a. Log into SecurView as an Administrator user, then select the **Exit to Windows** tab.
 - b. From the Windows desktop, double-click the **MediCal QAWeb** icon (or select **Start > Programs > Barco > MediCal QAWeb Agent**).
 - c. From the main MediCal QAWeb window, select **Switch User**.
 - d. Log into MediCal QAWeb as the **Advanced** user with the password 'advanced' (case-sensitive).
4. The *MediCal QAWeb Agent* window opens. Select the **Status** icon.
 5. The *Workstation > Status* window opens. In the 'Action History' section, select the **View the history of all actions on this workstation** link. The *Action History* window opens. This window displays all of the actions run on the workstation during one month.



Note

Use the **From** and **To** calendar menu to specify a date range for the Action History results.

Date	Name	Display	Operator	Result
Sep 12, 20...	Visual Test	Barco MDRC 2120, 9382002606	Priscilla	OK
Sep 12, 20...	Visual Test	Barco MDNG-5121 BB, 1890085...	Priscilla	OK
Sep 12, 20...	Visual Test	Barco MDNG-5121 BB, 1890085...	Priscilla	OK
Sep 10, 20...	Auto-calibration	Barco MDNG-5121 BB, 1890085...	Administr...	OK
Sep 10, 20...	Auto-calibration	Barco MDNG-5121 BB, 1890085...	Administr...	OK
Sep 10, 20...	Auto-calibration	Barco MDNG-5121 BB, 1890085...	Administr...	OK
Sep 10, 20...	Auto-calibration	Barco MDNG-5121 BB, 1890085...	-	NOT OK
Sep 10, 20...	Hologic Compliance T...	-	Administr...	OK
Sep 10, 20...	Auto-calibration	Barco MDNG-5121 BB, 1890085...	QAWeb	OK
Sep 10, 20...	Auto-calibration	Barco MDNG-5121 BB, 1890085...	QAWeb	OK
Sep 10, 20...	Auto-calibration	Barco MDRC 2120, 9382002606	QAWeb	OK

Figure 21: Action History Window

6. Select **View as PDF**.



Note

The SecurView workstation must have Adobe Acrobat Reader installed in order to view the Action History as a .pdf file.

7. The *QAWeb Action History .pdf* file opens. Select **File > Save As...**
8. Navigate to the USB drive where you want to save the QAWeb Action History .pdf file. Select **Save**.
9. Select **Close** twice, to return to the *Workstation > Status* window.
10. Close all open *MediCal QAWeb* windows.
11. Remove the USB drive from the SecurView workstation.
12. Insert the USB drive into a computer with Adobe Acrobat Reader installed and printer capabilities.
13. Open the QAWeb Action History .pdf file, then select **File > Print**.
14. The print dialog box opens. Specify the printing options, then select **Print**.

6.2 Scheduling the Hologic Compliance Test

By default, the Hologic Compliance Test automatically runs weekly (except on systems using external photometer sensor displays). Use this procedure to change the time/day of the scheduled Hologic Compliance Test.

1. Log out any user from the SecurView DX application.
2. To start MediCal QAWeb, press the **Windows**  key, then select **Programs > Barco > MediCal QAWeb Agent**.



Note (Windows XP users):

After logging out of SecurView, the Windows key is sometimes not active, which prevents users from manually starting up the MediCal QAWeb software. In such a situation, start MediCal QAWeb as follows:

- a. Log into SecurView as an Administrator user, then select the **Exit to Windows** tab.
 - b. From the Windows desktop, double-click the **MediCal QAWeb** icon (or select **Start > Programs > Barco > MediCal QAWeb Agent**).
 - c. From the main MediCal QAWeb window, select **Switch User**.
 - d. Log into MediCal QAWeb as the **Advanced** user with the password 'advanced' (case-sensitive).
3. The *MediCal QAWeb Agent* window opens. Select the **Status** icon.
 4. The *Workstation > Status* window opens. Select **Info** next to 'Hologic Compliance Test'.
 5. The *Hologic Compliance Test* window opens. Select **Modify** next to 'Frequency'.
 6. The *MediCal QAWeb login* window opens. By default, the User is 'Advanced'. Type **advanced** (case sensitive) in the 'Password' field, then select **OK**.
 7. The *Modify Hologic Compliance Test Frequency* window opens. Select **Custom** from the Frequency: drop-down menu, then select **Properties**.
 8. The *Modify Custom Frequency of Hologic Compliance Test* window opens. In the 'Timing' section, select the test start time, then select the day(s) you want the test to run. Select **OK**.
 9. At the *Modify Hologic Compliance Test Frequency* window, select **OK**.
 10. Close all open windows.

Appendix A SecurView Annual QC Form for Medical Physicists

Complete this form once a year for each SecurView diagnostic workstation.

Table 2: Annual QC Form for Medical Physicists

System Information				
SecurView SN				
Photometer SN				
Barco Display	Left Display	Pass/Fail	Right Display	Pass/Fail
Serial Number				
White Level Performance	cd/m ²		cd/m ²	
Luminance Response	%		%	
Barco Display	Single Display		Pass/Fail	
Serial Number				
White Level Performance	cd/m ²			
Luminance Response	%			
Comments:				
Signature:			Date:	

Table 3: Performance Criteria

Barco Display	White Level Luminance	White Level Performance	DICOM GSDF Performance
Coronis Uniti MDMC-12133	600 - 1000 cd/m ²	± 6%	± 10%
High-Brightness MDMG-5221	600 - 1000 cd/m ²	± 6%	± 10%
Coronis Fusion 10MP MDCG-10130	500 cd/m ²	± 6%	± 10%
Coronis 5MP MDMG-5121	600 cd/m ²	± 6%	± 10%
Coronis 5MP MFGD-5621 HD	600 cd/m ²	± 6%	± 10%
Coronis 5MP MFGD-5421	500 cd/m ²	± 6%	± 10%
Nio 5MP MDNG-6121	500 cd/m ²	± 6%	± 10%
Nio 5MP MDNG-5121	500 cd/m ²	± 6%	± 10%
Nio 5MP MDNG-5221	500 cd/m ²	± 6%	± 10%

Appendix C Running Barco Coronis Uniti Auto-calibration Manually

Follow this procedure to manually run Medical QAWeb's Auto-calibration feature for the 12MP Barco Coronis Uniti display with SteadyColor Calibration.

1. Log into SecurView as an Administrator user.
Username: **admin**
Password: **admin**
2. Select the **Exit to Windows** tab. Wait until the application has fully closed.
3. At the task bar, select **Start**, then **Log Off**.
4. Log into Windows as the customer administrator.
Username: **customer**
Password: **Simply-The-Best**
5. To start MediCal QAWeb, press the **Windows**  key, then select **Programs > Barco > MediCal QAWeb Agent**.
6. The *MediCal QAWeb Agent* window opens. Select the **Status** icon.
7. The *Workstation > Status* window opens. Select **Run** next to 'Auto-calibration'.



Note

When you manually run the Auto-calibration Test, you may be prompted for a password. By default, the password is 'advanced' (case sensitive).

After the Auto-calibration has finished running:

1. Select **Start > Log Off**.
2. Log into Windows as **SCR**. The SecurView application automatically restarts.



Note

If the SCR user requires a password you do not have, reboot the workstation to restart the SecurView application automatically.

HOLOGIC®



Hologic Inc.

36 Apple Ridge Road
Danbury, CT 06810 USA
1.800.447.1856
www.hologic.com

Hologic (Australia) Pty Ltd.

Suite 302, Level 3
2 Lyon Park Road
Macquarie Park NSW 2113
Australia

Hologic Hong Kong, Inc.

7th Floor, Biotech Centre 2
No. 11 Science Park West Avenue
Hong Kong Science Park
Shatin, New Territories
Hong Kong



Hologic BV

Da Vincilaan 5
1930 Zaventem
Belgium
Tel: +32 2 711 46 80
Fax: +32 2 725 20 87

CE
2797