

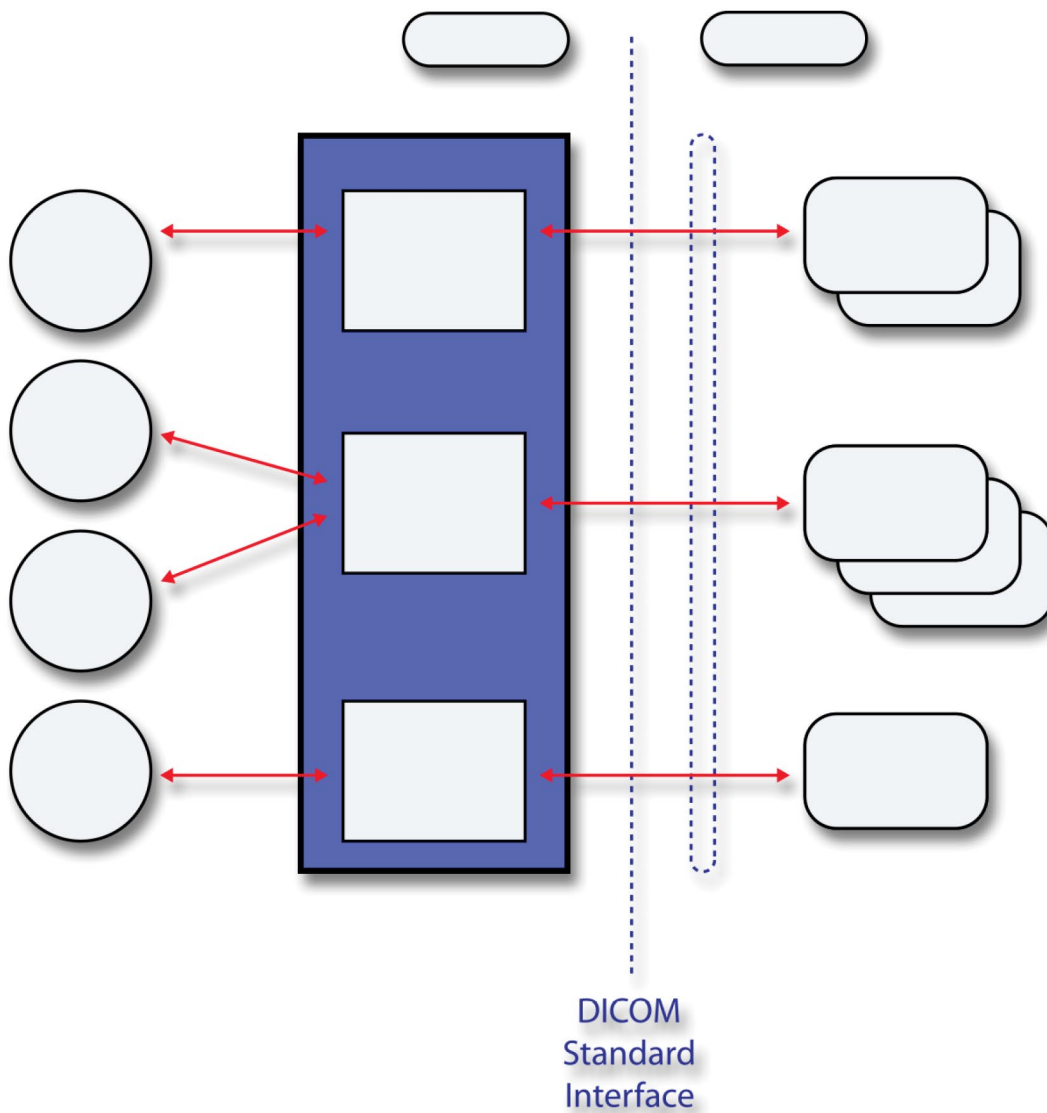

Digital Mammography System

Digital Tomosynthesis System



DICOM Conformance Statement

For Selenia® Dimensions® Acquisition Workstation

Software Version 1.8

MAN-10817 Revision 001

HOLOGIC®

Selenia® Dimensions®

Digital Mammography System

Digital Tomosynthesis System

DICOM Conformance Statement for Selenia Dimensions Acquisition Workstation Software Version 1.8

Part Number MAN-10817

Revision 001

September 2023

Product Support

USA: +1.877.371.4372

Asia: +852 37487700

Europe: +32 2 711 4690

Australia: +1 800 264 073

All Other: +1 781 999 7750

Email: BreastHealth.Support@hologic.com

© 2023 Hologic, Inc. Printed in the USA. This manual was originally written in English.

Hologic, Selenia® Dimensions®, and associated logos are trademarks and/or registered trademarks of Hologic, Inc., and/or its subsidiaries in the United States and/or other countries. All other trademarks, registered trademarks, and product names are the property of their respective owners.

This product may be protected by one or more U.S. or foreign patents as identified at www.Hologic.com/patent-information.



Hologic, Inc.
600 Technology Drive
Newark, DE 19702 USA
1.800.447.1856

HOLOGIC®

Table of Contents

TABLE OF CONTENTS3

1.0 OVERVIEW5

2.0 INTRODUCTION.....7

2.1. AUDIENCE7

2.2. REMARKS7

2.3. DEFINITIONS, TERMS AND ABBREVIATIONS8

2.4. REFERENCES.....8

3.0 NETWORKING.....9

3.1. IMPLEMENTATION MODEL.....9

3.1.1 *Application Data Flow*9

3.1.2 *Functional Definition of AE's*11

3.1.3 *Sequencing of Real World Activities*13

3.2. AE SPECIFICATIONS15

3.2.1 *Modality Worklist Client AE*15

3.2.2 *Modality PPS Client AE*.....19

3.2.3 *Print Client AE*.....24

3.2.4 *Storage Client AE*.....32

3.2.5 *Storage Commitment Client AE*37

3.2.6 *Query/Retrieve Client AE*.....40

3.2.7 *Storage Server AE*43

3.2.8 *Verification AE*.....46

3.3. NETWORK INTERFACES49

3.3.1 *Physical Network Interface*49

3.3.2 *Additional Protocols*49

3.4. CONFIGURATION49

3.4.1 *AE Title/Presentation Address Mapping*.....49

3.4.2 *Configuration Parameters for Local AEs*.....52

4.0 MEDIA INTERCHANGE.....54

4.1. IMPLEMENTATION MODEL.....54

4.1.1 *Application Data Flow Diagram*.....54

4.1.2 *Functional Definition of AEs*.....54

4.1.3 *Sequencing of Real World Activities*55

4.1.4 *File Meta Information for Implementation Class Version*55

4.2. AE SPECIFICATIONS55

4.2.1 *Media Server AE Specification*.....55

4.3. AUGMENTED AND PRIVATE APPLICATION PROFILES57

4.4.	MEDIA CONFIGURATION.....	57
5.0	SUPPORT OF CHARACTER SETS	57
6.0	SECURITY	57
7.0	ANNEXES.....	58
7.1.	IOD CONTENTS	58
7.1.1	<i>Created SOP Instance(s).....</i>	<i>58</i>
7.1.2	<i>Usage of Attributes from Received IODs.....</i>	<i>96</i>
7.1.3	<i>Attribute Mapping</i>	<i>97</i>
7.1.4	<i>Coerced/Modified Attributes.....</i>	<i>98</i>
7.2.	DATA DICTIONARY OF PRIVATE ATTRIBUTES	98
7.3.	CODED TERMINOLOGY AND TEMPLATES.....	99
7.4.	GRAYSCALE IMAGE CONSISTENCY.....	99
7.5.	STANDARD EXTENDED/SPECIALIZED/PRIVATE SOP CLASSES.....	99
7.5.1	<i>Secondary Capture Image Storage SOP Class</i>	<i>99</i>
7.5.2	<i>Breast Tomosynthesis Image Storage SOP Class</i>	<i>100</i>
7.5.3	<i>CT Image Storage SOP Class</i>	<i>101</i>
7.6.	PRIVATE TRANSFER SYNTAXES.....	101

1.0 Overview

The Hologic® Selenia® Dimensions® Acquisition Workstation implements the necessary DICOM services to:

- Download work lists from one or more information systems
- Send acquired Digital Mammography X-Ray Image - For Processing, any DICOM conformant Digital Mammography X-Ray Image - For Presentation images, Hologic 3D mammography™ Raw Projections, Processed Projections, Reconstructed Slices, Secondary Capture Image, Hologic Grayscale Softcopy Presentation State objects and/or X-Ray Radiation Dose structured reports to a networked storage device or removable media

**Note**

Hologic 3D mammography Raw Projections and Processed Projections are encapsulated within Secondary Capture Image objects in a proprietary format. Reconstructed Slices may be encapsulated within Secondary Capture Image objects in a proprietary format, stored as Breast Tomosynthesis Image or CT Image. A synthesized 2D digital image (C-View™ 2D) can be stored as Digital Mammography X-Ray Image - For Presentation or Breast Tomosynthesis Image with one frame.

**Note**

Hologic reserves the right to change, without notice, how data is packed into Hologic's proprietary SCO objects. Hologic recommends against decoding these proprietary objects as the data packing methodology may vary over time. Furthermore, Hologic makes no representation or warranty that any third party product will or can work with Hologic's proprietary SCO objects at any point in time.

**Note**

C-View 2D images are created only if the option is authorized and enabled. Not all features may be available in all markets.

- Request Storage Commitment from a networked storage device
- Send performed procedure status to a networked device
- Query for Hologic Digital Mammography X-Ray Image - For Processing images, any DICOM conformant Digital Mammography X-Ray Image - For Presentation images, Hologic 3D mammography Raw Projections, Processed Projections, Reconstructed Slices, Hologic Grayscale Softcopy Presentation State and/or Secondary Capture Image objects from a networked storage device
- Retrieve Hologic Digital Mammography X-Ray Image - For Processing images, any DICOM conformant Digital Mammography X-Ray Image - For Presentation images, Hologic 3D mammography Raw Projections, Processed Projections, Reconstructed Slices, Secondary Capture Image and Hologic Grayscale Softcopy Presentation State objects from a networked storage device or removable media
- Store Hologic Digital Mammography X-Ray Image - For Processing images, any DICOM conformant Digital Mammography X-Ray Image - For Presentation images, Hologic 3D mammography Raw Projections, Processed Projections, Reconstructed Slices, Secondary Capture Image and Hologic Grayscale Softcopy Presentation State objects received from an external device



Note

Storing received Reconstructed Slices in CT Image Storage format and X-Ray Radiation Dose SR Storage objects is not supported.

- Print any DICOM conformant Digital Mammography X-Ray Image - For Presentation images, Hologic 3D mammography Processed Projections, Reconstructed Slices, to a networked hardcopy device.

Table 1-1 provides an overview of the network services supported by the Selenia Dimensions Acquisition Workstation.

*Table 1-1
NETWORK SERVICES*

SOP Classes	User of Service (SCU)	Provider of Service (SCP)
Transfer		
Digital Mammography X-Ray Image Storage – For Presentation	Yes	Yes
Digital Mammography X-Ray Image Storage – For Processing	Yes	Yes
Secondary Capture Image Storage	Yes	Yes
Breast Tomosynthesis Image Storage	Yes	Yes
CT Image Storage	Yes	No
Grayscale Softcopy Presentation State Storage	Yes	Yes
X-Ray Radiation Dose SR Storage	Yes	No
Print Management		
Basic Grayscale Print Management Meta SOP Class	Yes	No
Print Job SOP Class	Option	No
Presentation LUT SOP Class	Option	No
Workflow Management		
Modality Worklist Information Model – FIND	Option	No
Modality Performed Procedure Step SOP Class	Option	No
Storage Commitment Push Model SOP Class	Option	No
Query/Retrieve		
Study Root Query/Retrieve Information Model - FIND	Option	No
Study Root Query/Retrieve Information Model – MOVE	Option	No

Table 1-2 provides an overview of the Media Storage Application Profiles supported by the Selenia Dimensions Acquisition Workstation.

*Table 1-2
MEDIA SERVICES*

Media Storage Application Profile	Write Files (FSC or FSU)	Read Files (FSR)
Compact Disk - Recordable		
General Purpose CD-R	Yes	Yes
General Purpose DVD-RAM	Yes	Yes
General Purpose USB	Yes	Yes

2.0 Introduction

Hologic, Inc. develops and markets a full line of mammography products including the Selenia Dimensions full-field digital mammography system with Hologic 3D mammography option.

The Selenia Dimensions Acquisition Workstation is a component of the Selenia Dimensions system. It provides an interface to the amorphous selenium X-ray detector as an image acquisition device, routing acquired images and accompanying information to output devices through DICOM interfaces. The Acquisition Workstation uses a graphical user interface (GUI) with a touch screen monitor, keyboard, pointing device (trackball), and image display monitor.

2.1 Audience

This document contains the DICOM conformance claim for the Selenia Dimensions Acquisition Workstation. This document is intended to aid in connecting the Acquisition Workstation to other components that make use of the DICOM standard for interconnecting networked imaging devices.

The information within this document applies to Selenia Dimensions AWS Software version 1.8. The reader of this document should be familiar with the DICOM standard and PACS components that utilize the standard.

2.2 Remarks

A DICOM conformance statement, the structure and content of which are stipulated by the DICOM standard, is intended to aid in determining the suitability of interconnecting digital imaging devices. References to specific functionality in a conformance statement are not sufficient to guarantee interoperability between components. The following should be considered when evaluating interoperability:

- The Acquisition Workstation conformance statement provides a starting point for ascertaining whether the product can communicate with other systems.
- The only way to know for certain whether the Acquisition Workstation can interoperate with other systems is to perform connectivity testing.
- This document represents a best effort to document the functionality of commercial versions of the Acquisition Workstation and is not a functional specification of any Hologic component or product. Hologic reserves the right to make changes at any time to the functionality of the DICOM components described herein, and is committed to following the evolution of the DICOM standard.

2.3 Definitions, Terms, and Abbreviations

Amorphous Selenium: Semiconductor material used in the direct capture X-ray detector of the Selenia.

AE: Application Entity

AWS: Acquisition Workstation

C-View: 2D digital image generated from Hologic 3D mammography data

DICOM: Digital Imaging and Communications in Medicine

DIMSE: DICOM Message Service Element

Direct Capture: Technique used to convert X-ray energy directly into electrical signals without using intensifying screens or scintillation.

FSC: File-set Creator

FSR: File-set Reader

GSPPS: Grayscale Softcopy Presentation State

HIPAA: Health Insurance Portability and Accountability Act

IOD: Information Object Definition

JPEG: Joint Photographic Experts Group (data compression techniques)

LUT: Lookup Table

MPPS: Modality Performed Procedure Step

MWL: Modality Worklist

NEMA: National Electrical Manufacturers Association

PACS: Picture Archive and Communications System (image management and long-term storage)

PDU: Protocol Data Unit

Q/R: Query/Retrieve

SC: Secondary Capture

SCP: Service Class Provider

SCU: Service Class User

SOP: Service Object Pair

SR: Structured Report

TCP/IP: Transmission Control Protocol/Internet Protocol

UID: Unique Identifier

2.4 References

- NEMA PS3 / ISO 12052, Digital Imaging and Communications in Medicine (DICOM) Standard, National Electrical Manufacturers Association, Rosslyn, VA, USA (available free at <http://medical.nema.org/>)

3.0 Networking

3.1 Implementation Model

3.1.1 Application Data Flow

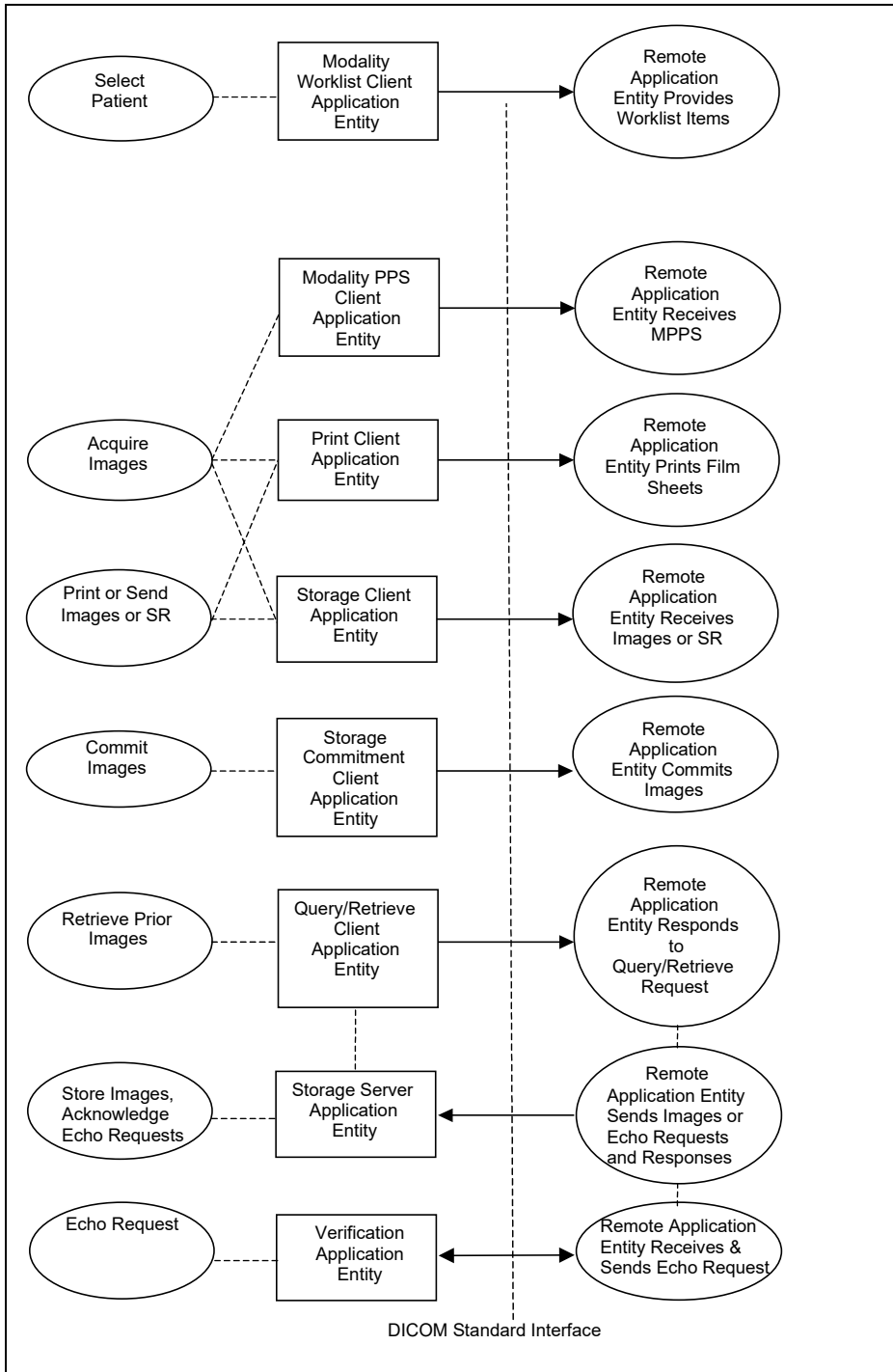

- The Modality Worklist Client Application Entity requests and receives Worklist information from one or more remote AEs containing patient schedule and procedure information. It is associated with the local real-world activity “Select Patient”. “Select Patient” is performed as a result of a user request or can be performed automatically at specific time intervals. The Modality Worklist Client queries the selected remote AE for worklist items and provides to the user the set of worklist items matching the query request.
- The Modality Performed Procedure Step (PPS) Client Application Entity sends MPPS information to a preconfigured remote AE. It is associated with the local real-world activity “Acquire Images”. When the “Acquire Images” local real-world activity is performed, the Modality PPS Client creates and updates MPPS Instances managed by the remote AE. Accepting the first acquired image results in automated creation of a MPPS Instance. User actions to complete, pend, or discontinue an imaging procedure result in automated update of a MPPS Instance.
- The Print Client Application Entity prints images to film on a remote AE (Printer). It is associated with the local real-world activities “Acquire Images” and “Print or Send Images or SR”. When a user performs the “Acquire Images” local real-world activity, remote Print AE destinations will receive images as they are acquired and accepted. When printing images as they are acquired, only the 2D images will be printed. “Print or Send Images or SR” can be performed upon user request for a selected procedure or specific images. This allows the user to print 2D images and also Tomosynthesis Reconstructed Slices and/or Processed Projections based on system configurable parameters. When a selected remote AE is a Printer, the Print Client creates a print job within the print queue, containing one or more virtual film sheets composed from the acquired or selected images.
- The Storage Client Application Entity sends images to a remote AE. It is associated with the local real-world activities “Acquire Images” and “Print or Send Images or SR”. When a user performs the “Acquire Images” local real-world activity, remote AE destinations are selected to receive images either individually as they are acquired and accepted, or as a group at the close of the procedure. Remote AE destinations may also receive SR at the close of the procedure. “Print or Send Images or SR” is performed upon user request for a selected procedure or specific images or SR to be sent to one or more remote AEs. If the remote AE is configured as an archive device with storage commitment enabled, the “Commit Images” local real-world activity is triggered.
- The Query/Retrieve Client Application Entity queries and retrieves images. “Retrieve Prior Images” is performed upon user request. The Query/Retrieve Client queries a remote AE for patient studies and provides the list of studies matching the query request. Through “Retrieve Prior Images” the user can select the patient studies to be retrieved. The Query/Retrieve Client issues a retrieve request for the selected patient studies.
- The Storage Server Application Entity receives echo requests, images, and/or GSPS objects from a remote AE. The Storage Server Application Entity is available whenever the Selenia Dimensions application is running.
- The Verification Application Entity sends an echo request to a remote AE. The Verification Application Entity can also receive a request from a remote AE. The Verification Application Entity is available as part of the Selenia Dimensions Service Tool utility.

3.1.2 Functional Definition of AE's

Multiple local Application Entities may be active simultaneously.

3.1.2.1 Functional Definition of Modality Worklist Client Application Entity

The Modality Worklist Client AE attempts to download a worklist from each configured remote node. If the Modality Worklist Client establishes an Association to a remote AE, it will accept all worklist item responses via the open Association. User interactive and automated query results are displayed and stored in a worklist. The resulting worklist is updated from subsequent automated worklist queries. While receiving the worklist responses, if the configurable limit of items is exceeded, an error is reported to the user. Those items that exceeded the configurable limit are not displayed.

3.1.2.2 Functional Definition of Modality PPS Client Application Entity

The Modality PPS Client AE automatically creates a MPPS Instance for the remote AE after the first image for a procedure is acquired and accepted. Updates to MPPS Instances are sent automatically to the remote AE when the user selects to close a procedure with Complete, Pend, or Discontinue. The user may update MPPS Instances to Completed or Discontinued manually.

3.1.2.3 Functional Definition of Print Client Application Entity

When an internal request to create a hardcopy of image data is generated, the Print Client AE will become active. The print job is created and resides in the Print Queue. The Print Client then attempts to establish an association with the remote printer. If the printer is operating normally, the film sheets described within the print job will be printed. Changes in printer status (e.g., out of film) are detected and reported to the user. If the printer is not operating normally, the print job will be set to an error state and retried. The retry timer and retry count can be configured for the Print Client. Upon reaching the retry limit, the user is notified and the print job remains in the queue with a status of stopped. The user may view the status of the print job in the Print Queue and restart the job via a job control interface.

When the Print Job SOP Class is configured, a configured print job timeout controls how long Associations remain open waiting for the print job to complete. When the Print Job SOP Class is not used, the established Association remains open until the printer responds to a status request that is sent after print action is requested, or until the Print Client times out waiting for a response.

3.1.2.4 Functional Definition of Storage Client Application Entity

The existence of a store job in the output queue will activate the Storage Client AE. An association request is sent to the destination AE and upon successful negotiation of a Presentation Context the image or SR transfer is started. If the association cannot be opened or the store request fails, the related store job is set to an error state and can be restarted by the user via job control interface. For some error conditions, such as timeouts, the Storage Client will attempt to retry a failed store job automatically. The retry timer and retry count can be configured for the Storage Client. Upon reaching the retry limit, the user is notified and the store job remains in the queue with a status of stopped. The user is notified when a store job does not complete successfully. The user may view the status of store jobs in the output queue.

3.1.2.5 Functional Definition of Storage Commitment Client Application Entity

The existence of a commit job in the output queue will activate the Storage Commitment Client AE. An association request is sent to the destination AE, and upon successful negotiation commitment of the image is requested. The Storage Commitment Client AE waits for commitment confirmation on a separate association. The listening port is always active for commitment confirmation when the Selenia Dimensions application is running.

If the commit request association cannot be opened or the commit request fails, the related commit job is set to an error state and can be restarted by the user via job control interface. For some error conditions, such as timeouts, the Storage Commitment Client will attempt to resend a failed commit job request automatically. The retry timer and retry count can be configured for the Storage Commitment Client. The user is notified if the remote AE does not accept a commit job request. The user may also view the status of output queues.

3.1.2.6 Functional Definition of Query/Retrieve Client Application Entity

The Query/Retrieve Client AE is activated when a user initiates a query job to a remote AE. An association request is sent to the remote AE and upon successful negotiation, a query is sent to the remote AE. The query content is based on the query job and the configured query method (e.g., relational vs. hierarchical). Given the query results, user selection of one or more studies and/or series to be retrieved from the remote AE triggers the Query/Retrieve Client to send a retrieve request. The Storage Server AE is active whenever the application is running and will receive the study. If an association cannot be opened or the query or retrieve request fails, an error is generated to notify the user and the query job is deleted.

3.1.2.7 Functional Definition of Storage Server Application Entity

The Storage Server AE is active (i.e., listen port is active) to accept echo and storage requests whenever the Selenia Dimensions application is running. The received Instances are stored to a temporary directory and then imported to the database, from which they may be listed and viewed through the user interface.

3.1.2.8 Functional Definition of Verification Application Entity

The Verification AE is available to the user as a DICOM troubleshooting tool in the Service Tool utility. It is available to test all remote SCP devices.

3.1.3 Sequencing of Real World Activities

A user initiates DICOM storage or print (printing 2D images) by selecting one or more output devices from a list, and then acquiring and accepting a digital mammography image and/or Hologic 3D mammography images. Depending on configuration, the image is transmitted to the selected remote AEs immediately, or all accepted images are transmitted when the user closes the procedure. When Storage Commitment is enabled, a storage commitment request is sent for each image that is stored successfully. The user may also initiate DICOM storage or print separate from the image acquisition procedure by selecting one or more images from a list of patient studies and selecting a destination. This is the default behavior of the system. There are other configurations that may result in different behaviors.

In cases where error(s) occur during transmission, the affected job(s) will be retried if the error condition is temporary; otherwise it will be stopped. The user is always notified when an error occurs. The user may be able to cancel the job or restart the job if desired (depending on the error condition).

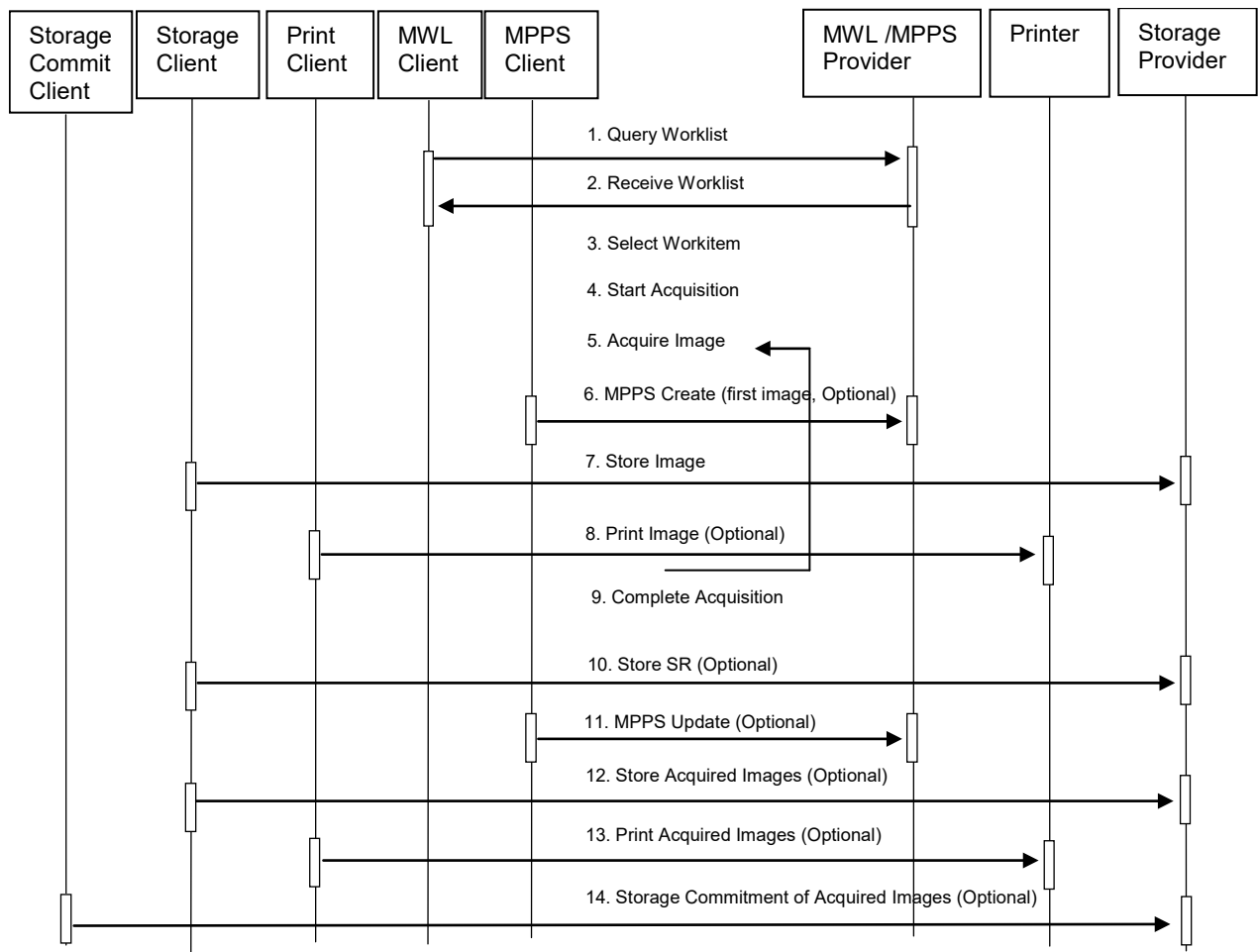

Figure 3.1-1: Image Acquisition Sequence Diagram

A user initiates DICOM query/retrieve by entering patient search criteria and executing a query. The matching patient's studies are displayed to the user. The user selects studies to retrieve and executes a retrieve request. The Acquisition Workstation receives the selected studies sent by the Query/Retrieve Provider, via the Storage Server AE.

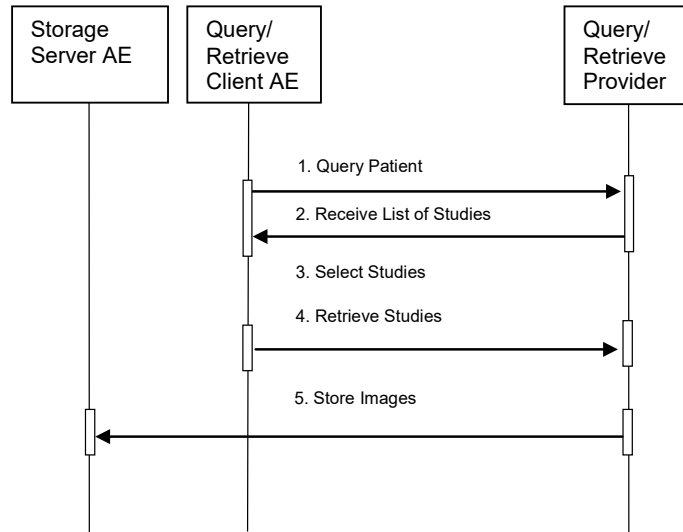

Figure 3.1-2: Query/Retrieve Sequence Diagram

A Storage Client AE initiates a DICOM store request to the Acquisition Workstation Storage Server AE. The Acquisition Workstation accepts the request and receives the studies/images sent by the Storage Client AE, via the Storage Server AE.

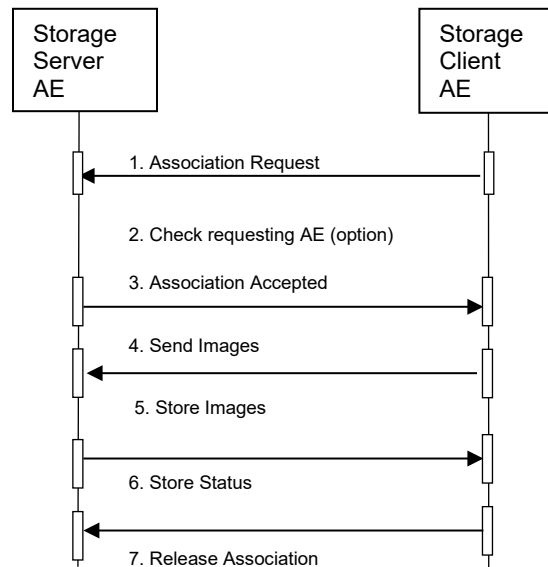

Figure 3.1-3: Storage Sequence Diagram

3.2 AE Specifications

3.2.1 Modality Worklist Client AE

3.2.1.1 SOP Classes

This Application Entity provides Standard Conformance to the following SOP Class:

Table 3.2.1-1

SOP CLASS FOR MODALITY WORKLIST CLIENT AE

SOP Class Name	SOP Class UID	SCU	SCP
Modality Worklist Information Model - FIND	1.2.840.10008.5.1.4.31	Yes	No

3.2.1.2 Association Policies

3.2.1.2.1 General

The DICOM standard Application context shall be specified.

Table 3.2.1-2

DICOM APPLICATION CONTEXT

Application Context Name	1.2.840.10008.3.1.1.1
--------------------------	-----------------------

3.2.1.2.2 Number of Associations

One association is initiated at a time for the Modality Worklist Client AE.

3.2.1.2.3 Asynchronous Nature

The Acquisition Workstation does not support asynchronous operations (multiple outstanding transactions over a single Association).

3.2.1.2.4 Implementation Identifying Information

Table 3.2.1-3

DICOM IMPLEMENTATION CLASS AND VERSION FOR MODALITY WORKLIST CLIENT

Implementation Class UID	1.2.840.114089.1.0.0.3.3.12
Implementation Version Name	DCF 3.3.12c

3.2.1.3 Association Initiation Policy

3.2.1.3.1 Select Patient

3.2.1.3.1.1 Description and Sequencing of Activities

The Select Patient request for a Modality Worklist update is initiated by user interaction, or automatically at defined periods (polling). When the user initiates Select Patient, the user enters data to be used as search criteria, and the data entered by the user are used as matching keys in the query. The search criteria (query keys) and return key attributes for user-entered queries and automatic updates are site configurable.

When an internal request for Modality Worklist update is received, the Modality Worklist Client attempts to establish an association with each configured remote AE. When the association is established a C-FIND request is made to retrieve a worklist using the defined matching and return keys. The Modality Worklist Client waits for C-FIND responses to be returned. The established association remains active until a C-FIND response from the remote AE indicates the end of worklist items or until a configurable timeout period expires. The Modality Worklist Client limits the number of stored worklist responses to a configurable maximum. If the maximum is exceeded during an interactive query, the user is notified that the maximum number of responses was exceeded.

For an automatic query, an alarm is posted. In either case, when the maximum is exceeded none of the responses received after the maximum is exceeded are displayed or stored.

The activity of the Modality Worklist Client is transparent to the user. The Modality Worklist Client queries each configured remote AE using the C-FIND operation and displays the returned worklist items. The user selects a worklist item to begin an exam. The Acquisition Workstation incorporates information from the selected worklist item into the acquired image object. The quality of the information returned in worklist items directly impacts the efficiency of the user. When a remote AE returns insufficient information or is off-line, the Acquisition Workstation requires the user to enter information manually that is used to identify the patient and procedure.

3.2.1.3.1.2 Proposed Presentation Contexts

The Modality Worklist Client attempts to establish associations using the following presentation contexts:

Table 3.2.1-4

PROPOSED PRESENTATION CONTEXTS FOR SELECT PATIENT

Presentation Context Table					
Abstract Syntax		Transfer Syntax		Role	Extended
Name	UID	Name List	UID List		Negotiation
Modality Worklist Information Model - FIND	1.2.840.10008.5.1.4.31	Implicit VR, Little Endian	1.2.840.10008.1.2	SCU	None

3.2.1.3.1.3 SOP Specific Conformance for Modality Worklist

The behavior of the Acquisition Workstation when encountering status codes in a Modality Worklist C-FIND response is summarized in the Table below. If the Acquisition Workstation receives a SCP response status other than "Success" or "Pending", the user is notified.

Table 3.2.1-5

DICOM COMMAND RESPONSE STATUS HANDLING BEHAVIOR

Service Status	Further Meaning	Error Code	Behavior
Success	Matching is complete	0000	The SCP has completed the matches. Worklist items are available for display. However, if more than the configured maximum number of responses were received, the AWS aborts the association and posts an error message to the user.
Pending	Matches are continuing	FF00	AWS continues the association with the Worklist Provider.
	Matches are continuing-Warning	FF01	AWS continues the association with the Worklist Provider.
Failure	Refused: Out of resources	A700	AWS Aborts association. Error message to user indicates "Dimse Exception: Out of resources"
	Identifier does not match SOP Class	A900	AWS Aborts association. Error message to user indicates "Dimse Exception: Data set does not match (error)"
	Unable to process	Cxxx	AWS Aborts association. Error message to user indicates "Dimse Exception: Cannot understand"

The behavior of the Acquisition Workstation during communication failure is summarized in the Table below.

Table 3.2.1-6

DICOM COMMAND COMMUNICATION FAILURE BEHAVIOR

Exception	Behavior
Timeout	The Association is aborted and an error message is posted to the user.
Association aborted by SCP	The responses received prior to the association being aborted are displayed. The error message "remote AE aborted association" is posted to the user.

The Modality Worklist Client is designed to function using a configurable query strategy. The query strategy defines:

- Query method (on-demand, polling, or both)
- Matching keys used
- Return keys requested
- Timeout parameters
- User displayed attributes

For user interactive queries Modality Worklist Client supports any combination of the following matching key attributes as a default:

Table 3.2.1-7

MWL SOP CLASS: SUPPORTED MATCHING KEYS – USER INTERACTIVE QUERIES

Matching Key Attribute	Tag	Matching Type
Patient's Name	(0010,0010)	Wild Card Matching
Patient ID	(0010,0020)	Single Value Matching
Accession Number	(0008,0050)	Single Value Matching
Requested Procedure ID	(0040,1001)	Single Value Matching
Scheduled Procedure Step Start Date	(0040,0002)	Range Matching

Note: The Acquisition Workstation supports all Matching Keys as specified in DICOM PS 3.4, Table K.6-1.

For automated queries the Modality Worklist Client supports any combination of the following matching key attributes:

Table 3.2.1-8

MWL SOP CLASS: SUPPORTED MATCHING KEYS – AUTOMATED QUERIES

Matching Key Attribute	Tag	Matching Type
Modality	(0008,0060)	Single Value Matching (default "MG")
Scheduled Procedure Step Start Date	(0040,0002)	Range Matching
Scheduled Station Name	(0040,0010)	Single Value Matching (Configurable Text)
Scheduled Station AE Title	(0040,0001)	Single Value Matching (Configurable Text)

The Modality Worklist Client can be configured to request any combination of return key attributes. Table 3.2.1-9 contains the default list of attributes that may be requested. Unexpected attributes returned in a C-FIND response are ignored. Requested return key attributes that are not supported by the Modality Worklist SCP are set to have no value.

Table 3.2.1-9

MODALITY WORKLIST SOP CLASS: REQUESTED RETURN KEY ATTRIBUTES

Module/Attribute	Tag
SOP Common	
Specific Character Set	(0008,0005)
Scheduled Procedure Step	
Scheduled Procedure Step Sequence	(0040,0100)
> Scheduled Station AE Title	(0040,0001)
> Scheduled Procedure Step Start Date	(0040,0002)
> Scheduled Procedure Step Start Time	(0040,0003)
> Modality	(0008,0060)
> Scheduled Performing Physician's Name	(0040,0006)
> Scheduled Procedure Step Description	(0040,0007)

Module/Attribute	Tag
> Scheduled Station Name	(0040,0010)
> Scheduled Procedure Step Location	(0040,0011)
> Scheduled Protocol Code Sequence	(0040,0008)
>> Code Value	(0008,0100)
>> Coding Scheme Designator	(0008,0102)
>> Code Meaning	(0008,0104)
> Scheduled Procedure Step ID	(0040,0009)
Requested Procedure	
Requested Procedure ID	(0040,1001)
Reason for Requested Procedure Code Sequence	(0040,100a)
>Code Value	(0008,0100)
>Coding Scheme Designator	(0008,0102)
>Code Meaning	(0008,0104)
Requested Procedure Description	(0032,1060)
Requested Procedure Code Sequence	(0032,1064)
> Code Value	(0008,0100)
> Coding Scheme Designator	(0008,0102)
> Code Meaning	(0008,0104)
Study Instance UID	(0020,000D)
Referenced Study Sequence	(0008,1110)
> Referenced SOP Class UID	(0008,1150)
> Referenced SOP Instance UID	(0008,1155)
Imaging Service Request	
Accession Number	(0008,0050)
Requesting Physician	(0032,1032)
Referring Physician's Name	(0008,0090)
Visit Identification	
Admission ID	(0038,0010)
Visit Status	
Current Patient Location	(0038,0300)
Patient Identification	
Patient's Name	(0010,0010)
Patient ID	(0010,0020)
Issuer of Patient ID	(0010,0021)
Other Patient IDs	(0010,1000)
Patient Demographic	
Patient's Birth Date	(0010,0030)
Patient's Sex	(0010,0040)
Patient's Address	(0010,1040)
Patient's Age	(0010,1010)
Patient Comments	(0010,4000)
Patient Medical	
Standard Extended	
Study Description	(0008,1030)
Procedure Code Sequence	(0008,1032)
>Code Value	(0008,0100)
>Coding Scheme Designator	(0008,0102)
>Code Meaning	(0008,0104)
Study ID	(0020,0010)

By default the attribute used to select the configured RIS code and configured procedure for a given modality worklist item is:

- Requested Procedure Code Sequence (0032,1064)
 >Code Value (0008,0100)

The Acquisition Workstation may be configured to use an alternate attribute for the RIS code. The alternative attributes are:

- Requested Procedure Code Sequence (0032,1064)
 >Code Meaning (0008,0104)
- Scheduled Procedure Step Sequence (0040,0100)
 > Scheduled Protocol Code Sequence (0040,0008),
 >>Code Value (0008,0100)
- Scheduled Procedure Step Sequence (0040,0100)
 > Scheduled Protocol Code Sequence (0040,0008),
 >>Code Meaning (0008,0104)
- Scheduled Procedure Step Sequence (0040,0100)
 >Scheduled Procedure Step Description (0040,0007)
- Scheduled Procedure Step Sequence (0040,0100)
 >Scheduled Procedure Step ID (0040,0009)
- Study Description (0008,1030)

When the configured RIS code attribute is missing from a returned modality worklist item or the value does not match a code in the procedure database, the user is prompted to select a procedure manually.

See Section 7.1.3 for the mapping of worklist item return key attributes to acquired image attributes.

3.2.1.4 Association Acceptance Policy

The Modality Worklist Client AE does not accept associations.

3.2.2 Modality PPS Client AE

3.2.2.1 SOP Classes

This Application Entity provides Standard Conformance to the following SOP Class:

*Table 3.2.2-1
SOP CLASS FOR MODALITY PPS CLIENT AE*

SOP Class Name	SOP Class UID	SCU	SCP
Modality Performed Procedure Step	1.2.840.10008.3.1.2.3.3	Yes	No

3.2.2.2 Association Policies**3.2.2.2.1 General**

The DICOM standard Application context shall be specified.

Table 3.2.2-2

DICOM APPLICATION CONTEXT

Application Context Name	1.2.840.10008.3.1.1.1
--------------------------	-----------------------

3.2.2.2.2 Number of Associations

One association is initiated at a time for the Modality PPS Client AE.

3.2.2.2.3 Asynchronous Nature

The Acquisition Workstation does not support asynchronous operations (multiple outstanding transactions over a single Association).

3.2.2.2.4 Implementation Identifying Information

Table 3.2.2-3

DICOM IMPLEMENTION CLASS AND VERSION FOR MODALITY PPS CLIENT

Implementation Class UID	1.2.840.114089.1.0.0.3.3.12
Implementation Version Name	DCF 3.3.12c

3.2.2.3 Association Initiation Policy**3.2.2.3.1 Acquire Images****3.2.2.3.1.1 Description and Sequencing of Activities**

The trigger to create a MPPS SOP Instance is to accept the first acquired image from a patient's procedure. The job to create the corresponding MPPS SOP Instance is added to the MPPS queue.

When the user selects Complete to close a procedure, a job to update the corresponding MPPS SOP Instance with final status of Completed is added to the MPPS queue.

When the user selects Pend to halt a procedure after at least one image has been accepted, a job to update the corresponding MPPS SOP Instance with status of In Progress is added to the MPPS queue.

When the user selects Discontinue to close a procedure, a job to update the corresponding MPPS SOP Instance with final status of Discontinued is added to the MPPS queue. If no MPPS SOP Instance exists (e.g., no image was acquired and accepted for the procedure), two jobs are added to the MPPS queue, first to create a MPPS SOP Instance, then to update the MPPS SOP Instance with final status of Discontinued.

When the user changes the status of a MPPS SOP Instance to Completed or Discontinued, a job to update the corresponding MPPS SOP Instance with the final status is added to the MPPS queue. A MPPS Instance that has been updated to a status of Completed or Discontinued can no longer be updated.

When the user selects to discontinue a procedure, the user may also select a preconfigured discontinuation reason from a customized list that initially is based on Context ID 9300.

Note: See DICOM PS 3.16 Content Mapping Resource for additional information.

The Acquisition Workstation includes attributes from the Radiation Dose module in MPPS SOP Instances when the Radiation Dose option is enabled.

The Acquisition Workstation supports creation of “unscheduled cases” by allowing MPPS Instances to be created for locally registered patients or procedures.

The Acquisition Workstation supports a 1-to-n relationship between Scheduled and Performed Procedure Steps. When a user adds one or more images to a Completed procedure, or adds a procedure to an Accession Number that already has a Completed procedure, a new MPPS SOP Instance is created for the corresponding Scheduled Procedure Step after the first image is accepted.

The Modality PPS Client AE initiates an Association with the remote MPPS SCP AE for each job in the MPPS Queue, to issue a:

- N-CREATE request for Modality Performed Procedure Step SOP Instance
- N-SET request to update the contents and status of a MPPS SOP Instance

The Modality PPS Client AE ensures that a N-CREATE request has been sent successfully for a MPPS SOP Instance prior to sending a MPPS N-SET request for the MPPS SOP Instance.

3.2.2.3.1.2 Proposed Presentation Contexts

The Modality PPS Client attempts to establish associations using the following presentation contexts:

*Table 3.2.2-4
PROPOSED PRESENTATION CONTEXTS FOR SELECT PATIENT*

Presentation Context Table					
Abstract Syntax		Transfer Syntax		Role	Extended Negotiation
Name	UID	Name List	UID List		
Modality Performed Procedure Step	1.2.840.10008.3.1.2.3.3	Implicit VR, Little Endian	1.2.840.10008.1.2	SCU	None
		Explicit VR, Little Endian	1.2.840.10008.1.2.1		
		Explicit VR, Big Endian	1.2.840.10008.1.2.2		

3.2.2.3.1.3 SOP Specific Conformance for Modality Performed Procedure Step

The behavior of the Acquisition Workstation when encountering status codes in a MPPS N-CREATE or N-SET response is summarized in the Table below. If the Acquisition Workstation receives a SCP response status other than "Success", the failure is logged. The user can check the status of MPPS jobs in the Managed Queues utility.

*Table 3.2.2-5
DICOM COMMAND RESPONSE STATUS HANDLING BEHAVIOR*

Service Status	Further Meaning	Error Code	Behavior
Success	Success	0000	The SCP has completed the operation successfully.
Warning	Any	Any	AWS aborts association.
Failure	Any	Any	AWS aborts association.

The behavior of the Acquisition Workstation during communication failure is summarized in the Table below. Depending on the type of failure, and retry configuration, the MPPS job may be retried several times before reporting an error.

Table 3.2.2-6

DICOM COMMAND COMMUNICATION FAILURE BEHAVIOR

Exception	Behavior
Timeout	The Association is aborted and the MPPS job is marked as failed. The reason is logged and the job status is reported in the Manage Queues user interface.
Association aborted by SCP	The MPPS job is marked as failed. The reason is logged and the job status is reported in the Manage Queues user interface.

The Modality PPS Client AE sends the following attributes in MPPS N-CREATE and N-SET requests. Empty cells indicate that the attribute is not sent.

Table 3.2.2-7

MPPS N-CREATE / N-SET REQUESTS

Attribute Name	Tag	N-CREATE	N-SET
Performed Procedure Step Relationship			
Referenced Patient Sequence	(0008,1120)	Zero Length	
Patient's Name	(0010,0010)	MWL or manual entry	
Patient ID	(0010,0020)	MWL or manual entry	
Patient's Birth Date	(0010,0030)	MWL or manual entry	
Patient's Sex	(0010,0040)	MWL or manual entry	
Scheduled Step Attributes Sequence	(0040,0270)	Always present	
>Study Instance UID	(0020,000D)	MWL or generated	
>Referenced Study Sequence	(0008,1110)	MWL or not sent	
>>Referenced SOP Class UID	(0008,1150)	MWL or not sent	
>>Referenced SOP Instance UID	(0008,1155)	MWL or not sent	
>Accession Number	(0008,0050)	MWL, manual or zero length	
>Requested Procedure ID	(0040,1001)	MWL, manual or zero length	
>Requested Procedure Description	(0032,1060)	MWL or zero length	
>Scheduled Procedure Step ID	(0040,0009)	MWL or zero length	
>Scheduled Procedure Step Description	(0040,0007)	MWL or zero length	
>Scheduled Protocol Code Sequence	(0040,0008)	MWL or zero length	
>>Code Value	(0008,0100)	MWL or not sent	
>>Coding Scheme Designator	(0008,0102)	MWL or not sent	
>>Code Meaning	(0008,0104)	MWL or not sent	
Performed Procedure Step Information			
Performed Procedure Step ID	(0040,0253)	Generated value	
Performed Station AE Title	(0040,0241)	Configured value	
Performed Station Name	(0040,0242)	Configured value	
Performed Location	(0040,0243)	Configured value	
Performed Procedure Step Start Date	(0040,0244)	Date first acquired image is accepted or rejected	
Performed Procedure Step Start Time	(0040,0245)	Time first acquired image is accepted or rejected	
Performed Procedure Step Status	(0040,0252)	IN PROGRESS	IN PROGRESS, COMPLETED or DISCONTINUED
Performed Procedure Step Description	(0040,0254)	Configured procedure description	Configured procedure description
Performed Procedure Type Description	(0040,0255)	Configured procedure description	Configured procedure description
Procedure Code Sequence	(0008,1032)	MWL or Zero Length	Same as Scheduled Protocol Code Sequence
>Code Value	(0008,0100)	MWL	
>Coding Scheme Designator	(0008,0102)	MWL	
>Code Meaning	(0008,0104)	MWL	

Attribute Name	Tag	N-CREATE	N-SET
Performed Procedure Step End Date	(0040,0250)	Zero length	Date of close procedure action [zero length if still IN PROGRESS]
Performed Procedure Step End Time	(0040,0251)	Zero length	Time of close procedure action [zero length if still IN PROGRESS]
Performed Procedure Step Discontinuation Reason Code Sequence	(0040,0281)		Not included when Exception Management option is not enabled. One item containing user selection if Exception Management option enabled
>Code Value	(0008,0100)		Code value
>Coding Scheme Designator	(0008,0102)		DCM
>Code Meaning	(0008,0104)		Code meaning
Image Acquisition Results			
Modality	(0008,0060)	Default = MG	
Study ID	(0020,0010)	MWL or generated value	
Performed Protocol Code Sequence	(0040,0260)	Configured procedure code	Configured procedure code
>Code Value	(0008,0100)		Code value
>Coding Scheme Designator	(0008,0102)		Coding scheme designator
>Code Meaning	(0008,0104)		Code meaning
Performed Series Sequence	(0040,0340)	Two Items from the first accepted image	One or two Items per accepted image
>Performing Physician's Name	(0008,1050)		Zero length
>Operators' Name	(0008,1070)		Current user
>Protocol Name	(0018,1030)		Same as Series Description
>Series Instance UID	(0020,000E)		Generated value
>Series Description	(0008,103E)		Configured value
>Retrieve AE Title	(0008,0054)		Zero length
>Referenced Image Sequence	(0008,1140)		One or more Items
>>Referenced SOP Class UID	(0008,1150)		UID for Digital Mammography X-Ray Image – For Presentation or For Processing or Secondary Capture Image or Breast Tomosynthesis Image
>>Referenced SOP Instance UID	(0008,1155)		Generated value
>Referenced Non-Image Composite SOP Instance Sequence	(0040,0220)		Zero Length
Radiation Dose			
Anatomic Structure, Space or Region Sequence	(0008,2229)		One Item (T-04000, SNM3, "Breast") if Radiation Dose option enabled
Total Number of Exposures	(0040,0301)	0 if Radiation Dose option enabled	Number of acquired images if Radiation Dose option enabled
Distance Source to Detector	(0018,1110)	Zero Length if Radiation Dose option enabled	Generated value if Radiation Dose option enabled
Entrance Dose	(0040,0302)	0 if Radiation Dose option enabled	Included when Radiation Dose option enabled Note: combined dose for the Left and Right breasts
Entrance Dose in mGy	(0040,8302)	Zero Length if Radiation Dose option enabled	Included when Radiation Dose option enabled Note: combined dose for the Left and Right breasts

Attribute Name	Tag	N-CREATE	N-SET
Exposure Dose Sequence	(0040,030E)	Zero Length if Radiation Dose option enabled	One item per acquired image if Radiation Dose option enabled
>Radiation Mode	(0018,115A)		CONTINUOUS
>KVP	(0018,0060)		Value from acquisition
>X-Ray Tube Current in μ A	(0018,8151)		Value from acquisition
>Exposure Time	(0018,1150)		Value from acquisition
>Filter Material	(0018,7050)		ALUMINIUM COPPER LEAD MOLYBDENUM RHODIUM SILVER TIN
Standard Extended			
Organ Dose	(0040,0316)	Zero length if Radiation Dose option enabled	Calculated value when Radiation Dose option is enabled Note: combined dose for the Left and Right breasts
Organ Exposed	(0040,0318)	Zero length if Radiation Dose option enabled	BREAST when Radiation Dose option is enabled.

3.2.2.4 Association Acceptance Policy

The Modality PPS Client AE does not accept associations.

3.2.3 Print Client AE

3.2.3.1 SOP Classes

This Application Entity provides Standard Conformance to the following SOP Classes:

Table 3.2.3-1
SOP CLASSES FOR PRINT CLIENT AE

SOP Class Name	SOP Class UID	SCU	SCP
Basic Grayscale Print Management Meta	1.2.840.10008.5.1.1.9	Yes	No
Print Job SOP Class	1.2.840.10008.5.1.1.14	Yes	No
Presentation LUT SOP Class	1.2.840.10008.5.1.1.23	Yes	No

3.2.3.2 Association Policies

3.2.3.2.1 General

The DICOM standard Application context shall be specified.

Table 3.2.3-2
DICOM APPLICATION CONTEXT

Application Context Name	1.2.840.10008.3.1.1.1
--------------------------	-----------------------

3.2.3.2.2 Number of Associations

One association is initiated at a time for the Print Client AE.

3.2.3.2.3 Asynchronous Nature

The Acquisition Workstation does not support asynchronous operations (multiple outstanding transactions over a single Association).

3.2.3.2.4 Implementation Identifying Information

Table 3.2.3-3

DICOM IMPLEMENTATION CLASS AND VERSION FOR PRINT CLIENT

Implementation Class UID	1.2.840.114089.1.0.0.3.3.12
Implementation Version Name	DCF 3.3.12c

3.2.3.3 Association Initiation Policy

3.2.3.3.1 Acquire Images / Print or Send Images or SR

3.2.3.3.1.1 Description and Sequencing of Activities

The Print Client attempts to establish an association with a remote print AE when an internal request to print one or more images is received. When the Print Job SOP Class is configured, the print job timeout controls how long associations remain open waiting for the print job to complete. When the Print Job SOP Class is not used, the association remains open until the remote print AE responds to a status request that is sent after print action is requested, or until the Print Client times out waiting for a response. The Presentation LUT SOP Class is an option that can be enabled on a per printer basis.

For requested image(s) to be printed the Print Client requests the establishment of an association with a Remote Print AE using the Basic Grayscale Print Management Meta SOP Class. If so configured the Print Client negotiates the optional Print Job SOP class and/or Presentation LUT SOP Class.

Once an association is established the Print Client sends print jobs to the remote print AE. Each print job consists of the following steps:

- The Print Client sends the remote print AE an N-GET request for the Printer SOP Class to determine the status of the printer. The Print Client records the status and continues. The Print Client sends an N-CREATE request to the remote print AE to create a film session. After receiving a successful N-CREATE response, the Print Client then sends an N-CREATE request to the remote print AE to create a film box containing a single image box. The remote print AE creates the film session, film box, and image box. The Presentation LUT SOP Class is an option that can be enabled on a per printer basis.

Note: When configured, the Presentation LUT SOP Class is negotiated upon a receiving a successful Film Session N-CREATE response.

- The Print Client sends the remote print AE an N-SET request to update the image box with the image pixel data and other information needed for the image to be printed as part of a film box.
- Once the image has been transferred, the Print Client sends the remote print AE an N-ACTION request for the film box. This triggers the remote print AE to print the film. Note that the Print Client does not request N-ACTION at the film session level.
- When the Print Job SOP Class is negotiated the Print Client polls the remote print AE by sending alternate N-GET requests for the Print Job and Printer SOP Classes at pre-configured intervals until an execution status of either "FAILURE" or "DONE" is received in an N-GET response or N-EVENT-REPORT request, or until the configured job timeout period expires.
- When the Print Job SOP Class is not used, the Print Client sends one N-GET request for the Printer SOP Class after the N-ACTION response is received. The association remains open until the N-GET response or a N-EVENT-REPORT request is received, or until the Print Client times out waiting for the N-GET response.
- Before closing the association under any circumstance, the Print Client sends an N-DELETE request for the film box and then for the film session.
- An alarm is posted to the user when a printer warning or failure status message is received from the remote print AE.

3.2.3.3.1.2 Proposed Presentation Contexts

The Print Client attempts to establish associations using the following presentation contexts:

Table 3.2.3-4

PROPOSED PRESENTATION CONTEXTS FOR ACQUIRE IMAGES

Presentation Context Table					
Abstract Syntax		Transfer Syntax		Role	Extended
Name	UID	Name List	UID List		Negotiation
Basic Grayscale Print Management Meta	1.2.840.10008.5.1.9	Implicit VR, Little Endian	1.2.840.10008.1.2	SCU	None
		Explicit VR, Little Endian	1.2.840.10008.1.2.1		
		Explicit VR, Big Endian	1.2.840.10008.1.2.2		
Print Job SOP Class	1.2.840.10008.5.1.14	Implicit VR, Little Endian	1.2.840.10008.1.2	SCU	None
		Explicit VR, Little Endian	1.2.840.10008.1.2.1		
		Explicit VR, Big Endian	1.2.840.10008.1.2.2		
Presentation LUT SOP Class	1.2.840.10008.5.1.1.23	Implicit VR, Little Endian	1.2.840.10008.1.2	SCU	None
		Explicit VR, Little Endian	1.2.840.10008.1.2.1		
		Explicit VR, Big Endian	1.2.840.10008.1.2.2		

3.2.3.3.1.3 SOP Specific Conformance for Print Client

The general behavior of the Print Client AE during communication failure is summarized in the Table below. This behavior is common to all SOP Classes supported by the Print Client AE. Depending on the type of failure, and retry configuration, the print job may be retried several times before reporting an error to the user.

Table 3.2.3-5

DICOM COMMAND COMMUNICATION FAILURE BEHAVIOR

Exception	Behavior
Timeout	The Association is aborted and an error message is posted to the user: "Print job was not completed in the allotted time, or timeout waiting for response. Status of print job is unknown."
Association aborted by SCP	An error message is posted to the user: "Cannot open socket to specified host/port, a network error has occurred, or received abort from remote system."

The Print Client supports various printer types that may expect different values for the film session, film box, and image box attributes. These attribute values are defined within model files for each specific printer. This section describes the DIMSE services and the attributes supported for various remote print AEs and includes the particular attributes that may be configured per printer type.

3.2.3.3.1.3.1 Specific Conformance to Basic Film Session SOP Class

Table 3.2.3-6

BASIC FILM SESSION SOP CLASS: SUPPORTED DIMSE OPERATIONS

Name	Description
N-CREATE	Creates the film session
N-DELETE	Deletes the film session

Table 3.2.3-7

BASIC FILM SESSION SOP CLASS: SUPPORTED ATTRIBUTES

Attribute Name	Tag	Supported Values	Default Value
Number Of Copies	(2000,0010)	1-10	1
Print Priority	(2000,0020)	HIGH, MED, LOW	High
Medium Type	(2000,0030)	BLUE FILM CLEAR FILM MAMMO BLUE FILM MAMMO CLEAR FILM	Configurable
Film Destination	(2000,0040)	(Configurable)	(Configurable)
Film Session Label	(2000,0050)	64 characters max.	Hologic Dimensions
Memory Allocation	(2000,0060)	(Configurable)	(Configurable)

The behavior of Print Client AE when encountering status codes in a N-CREATE or N-DELETE response is summarized in the Table below.

Table 3.2.3-8

FILM SESSION SOP CLASS RESPONSE STATUS HANDLING BEHAVIOR

Service Status	Further Meaning	Error Code	Behavior
Success	Success	0000	The SCP has completed the operation successfully. Proceed to next step.
Warning	Memory allocation	B600	Proceed to next step.
Failure	Any	Any	AWS Aborts association. Error message to user indicates "A DICOM DIMSE error was returned in a response." Specific status information is logged.

3.2.3.3.1.3.2 Specific Conformance to Basic Film Box SOP Class

Table 3.2.3-9

BASIC FILM BOX SOP CLASS: SUPPORTED DIMSE OPERATIONS

Name	Description
N-CREATE	Creates the film box
N-DELETE	Deletes the film box
N-ACTION	Prints the film box

Table 3.2.3-10

BASIC FILM BOX SOP CLASS: SUPPORTED ATTRIBUTES

Attribute Name	Tag	Supported Values	Default Value
Image Display Format	(2010,0010)	STANDARD\1,1	STANDARD\1,1
Annotation Display Format ID	(2010,0030)	(Configurable)	Configured to printer's requirements
Film Orientation	(2010,0040)	PORTRAIT LANDSCAPE	PORTRAIT
Film Size ID	(2010,0050)	8INX10IN 10INX12IN 10INX14IN 11INX14IN 14INX14IN 14INX17IN (Configurable per printer)	Configured per each printer's requirements with image matrix size, or set to calculate automatically for true size printing.
Magnification Type	(2010,0060)	REPLICATE BILINEAR CUBIC NONE	Configured per printer.
Smoothing Type	(2010,0080)	(Configurable)	Configured per printer.
Border Density	(2010,0100)	BLACK WHITE	Configured per printer.
Empty Image Density	(2010,0110)	BLACK WHITE	Configured per printer.
Min Density	(2010,0120)	numeric, OD x 100	Configured per printer.
Max Density	(2010,0130)	numeric, OD x 100	Configured per printer.
Trim	(2010,0140)	YES NO	Configured per printer.
Configuration Information	(2010,0150)	Cxxx, where xxx = Code Value obtained from printer vendors	Configured per printer.
Illumination	(2010,015E)	0-65535	Sent regardless if Presentation LUT SOP Class is successfully negotiated. Configurable per printer Default = 5000
Reflected Ambient Light	(2010,0160)	0-65535	Sent regardless if Presentation LUT SOP Class is successfully negotiated. Configurable per printer Default = 10
Referenced Film Session Sequence	(2010,0500)		
>Referenced SOP Class UID	(0008,1150)		1.2.840.10008.5.1.1.1
>Referenced SOP Instance UID	(0008,1155)		Returned by Print SCP in the Basic Film Session N-CREATE-RSP
Referenced Image Box Sequence	(2010,0510)		Returned by SCP
Referenced Presentation LUT Sequence	(2050,0500)	Sent only when Presentation LUT is successfully negotiated	Returned by the Print SCP only when Presentation LUT is successfully negotiated
>Referenced SOP Class UID	(0008,1150)		1.2.840.10008.5.1.1.23
>Referenced SOP Instance UID	(0008,1155)		Returned by Print SCP in the Basic Film Box N-CREATE-RSP

The behavior of Print Client AE when encountering status codes in a N-CREATE, N-ACTION, or N-DELETE response is summarized in the Table below.

Table 3.2.3-11

FILM BOX SOP CLASS RESPONSE STATUS HANDLING BEHAVIOR

Service Status	Further Meaning	Error Code	Behavior
Success	Success	0000	The SCP has completed the operation successfully. Proceed to next step.
Failure	Existing Film Box	C616	Proceed to next step.
Warning or Failure	Any	Any	AWS Aborts association. Error message to user indicates "A DICOM DIMSE error was returned in a response." Specific status information is logged.

3.2.3.3.1.3.3 Specific Conformance to Basic Image Box SOP Class

Table 3.2.3-12

BASIC IMAGE BOX SOP CLASS: SUPPORTED DIMSE OPERATIONS

Name	Description
N-SET	Updates an image box in a previously created film box.

Table 3.2.3-13

BASIC IMAGE BOX SOP CLASS: SUPPORTED ATTRIBUTES

Attribute Name	Tag	Supported Values	Default Value
Image Box Position	(2020,0010)	1	1
Polarity	(2020,0020)	NORMAL	NORMAL
Basic Grayscale Image Sequence	(2020,0110)		
> Samples Per Pixel	(0028,0002)	1	
> Photometric Interpretation	(0028,0004)	MONOCHROME2	
> Rows	(0028,0010)		Depends on image size
> Columns	(0028,0011)		Depends on image size
> Pixel Aspect Ratio	(0028,0034)	180\180	
> Bits Allocated	(0028,0100)	16	
> Bits Stored	(0028,0101)	12	
> High Bit	(0028,0102)	11	
> Pixel Representation	(0028,0103)	0	
> Pixel Data	(7FE0,0010)		
Magnification Type	(2010,0060)	REPLICATE BILINEAR CUBIC NONE	Configured per printer. Overrides corresponding Film Box attribute.
Smoothing Type	(2010,0080)	(Configurable)	Configured per printer. Sent only if Magnification Type is CUBIC. Overrides corresponding Film Box attribute.
Requested Image Size	(2020,0030)		Indicates required row size (true size) in mm.

The behavior of Print Client AE when encountering status codes in a N-SET response is summarized in the Table below:

Table 3.2.3-14

IMAGE BOX SOP CLASS N-SET RESPONSE STATUS HANDLING BEHAVIOR

Service Status	Further Meaning	Error Code	Behavior
Success	Success	0000	The SCP has completed the operation successfully. Proceed to next step.
Failure	Any	Any	AWS Aborts association. Error message to user indicates "A DICOM DIMSE error was returned in a response." Specific status information is logged.

3.2.3.3.1.3.4 Specific Conformance to Printer SOP Class

Table 3.2.3-15

PRINTER SOP CLASS: SUPPORTED DIMSE OPERATIONS

Name	Description
N-EVENT-REPORT	Receives status notification.
N-GET	Retrieves an instance of a physical printer.

The Print Client displays descriptive text corresponding to Printer Status Info (2110,0020) attribute values received from a remote print AE using the N-GET operation, or received via N-EVENT-REPORT. The displayed text is based on DICOM PS 3.3, C.13.9.1. When the remote print AE sends a Printer Status Info value that is not recognized, the Print Client displays the Printer Status Info value directly.

The behavior of Print Client AE when encountering status codes in a N-GET response is summarized in the Table below:

Table 3.2.3-16

PRINTER SOP CLASS N-GET RESPONSE STATUS HANDLING BEHAVIOR

Service Status	Further Meaning	Error Code	Behavior
Success	Success	0000	The SCP has completed the operation successfully. Proceed to next step.
Failure	Any	Any	AWS Aborts association. Error message to user indicates "A DICOM DIMSE error was returned in a response." Specific status information is logged.

3.2.3.3.1.3.5 Specific Conformance to Presentation LUT SOP Class

Table 3.2.3-17

PRESENTATION LUT SOP CLASS: SUPPORTED DIMSE OPERATIONS

Name	Description
N-CREATE	Creates a Presentation LUT to be referenced by a film box

Table 3.2.3-18

PRESENTATION LUT SOP CLASS: SUPPORTED ATTRIBUTES

Attribute Name	Tag	Supported Values	Default Value
Presentation LUT Shape	(2050,0020)	IDENTITY INVERSE LIN OD	Configurable per printer

The behavior of the Print SCU when encountering status codes in the N-CREATE response is summarized in the Table below:

Table 3.2.3-19

PRINTER SOP CLASS N-GET RESPONSE STATUS HANDLING BEHAVIOR

Service Status	Further Meaning	Error Code	Behavior
Success	Success	0000	The SCP has completed the operation successfully. Proceed to next step.
Failure	Any	Any	AWS Aborts association. Error message to user indicates "A DICOM DIMSE error was returned in a response." Specific status information is logged.

3.2.3.3.1.3.6 Specific Conformance to Print Job SOP Class

Table 3.2.3-20

PRINT JOB SOP CLASS: SUPPORTED DIMSE OPERATIONS

Name	Description
N-EVENT-REPORT	Receives status notification.
N-GET	Retrieves an instance of an existing print job.

The Print Client displays descriptive text corresponding to Execution Status Info (2100,0030) attribute values received from a remote print AE using the N-GET operation, or received via N-EVENT-REPORT. The displayed text is based on DICOM PS 3.3, C.13.9.1. When the remote print AE sends an Execution Status Info value that is not recognized, the Print Client displays the Execution Status Info value directly.

The behavior of Print Client AE when encountering status codes in a N-GET response is summarized in the Table below:

Table 3.2.3-21

PRINT JOB SOP CLASS N-GET RESPONSE STATUS HANDLING BEHAVIOR

Service Status	Further Meaning	Error Code	Behavior
Success	Success	0000	The SCP has completed the operation successfully. Proceed to next step.
Failure	Any	Any	AWS Aborts association. Error message to user indicates "A DICOM DIMSE error was returned in a response." Specific status information is logged.

3.2.3.4 Association Acceptance Policy

The Print Client AE does not accept associations.

3.2.4 Storage Client AE

3.2.4.1 SOP Classes

This Application Entity provides Standard Conformance to the following SOP Classes:

Table 3.2.4-1

SOP CLASSES FOR STORAGE CLIENT AE

SOP Class Name	SOP Class UID	SCU	SCP
Digital Mammography X-Ray Image Storage – For Presentation	1.2.840.10008.5.1.4.1.1.1.2	Yes	No
Digital Mammography X-Ray Image Storage – For Processing	1.2.840.10008.5.1.4.1.1.1.2.1	Yes	No
Secondary Capture Image Storage	1.2.840.10008.5.1.4.1.1.7	Yes	No
Breast Tomosynthesis Image Storage	1.2.840.10008.5.1.4.1.1.13.1.3	Yes	No
CT Image Storage	1.2.840.10008.5.1.4.1.1.2	Yes	No
Grayscale Softcopy Presentation State Storage	1.2.840.10008.5.1.4.1.1.11.1	Yes	No

X-Ray Radiation Dose SR Storage	1.2.840.10008.5.1.4.1.1.88.67	Yes	No
---------------------------------	-------------------------------	-----	----

3.2.4.2 Association Policies

3.2.4.2.1 General

The DICOM standard Application context shall be specified.

Table 3.2.4-2

DICOM APPLICATION CONTEXT

Application Context Name	1.2.840.10008.3.1.1.1
--------------------------	-----------------------

3.2.4.2.2 Number of Associations

Up to three associations are initiated at a time for the Storage Client AE.

3.2.4.2.3 Asynchronous Nature

The Acquisition Workstation does not support asynchronous operations (multiple outstanding transactions over a single Association).

3.2.4.2.4 Implementation Identifying Information

Table 3.2.4-3

DICOM IMPLEMENTATION CLASS AND VERSION FOR STORAGE CLIENT

Implementation Class UID	1.2.840.114089.1.0.0.3.3.12
Implementation Version Name	DCF 3.3.12c

3.2.4.3 Association Initiation Policy

3.2.4.3.1 Acquire Images / Print or Send Images or SR

3.2.4.3.1.1 Description and Sequencing of Activities

As a default, when the user accepts the image data (digital mammography and/or Hologic 3D mammography reconstructed slices and projections) acquired for a specific view, an internal request to transmit the image data to one or more pre-selected remote storage AEs is generated. The Storage Client then attempts to establish an association with a remote storage AE and transmits the image data. The Storage Client releases the association after receiving the response from the remote storage AE. This configuration allows image data to be transmitted as soon as it is acquired and accepted, without holding associations open for extended periods of time while a procedure is being performed.

The Acquisition Workstation may also be configured to postpone transmission until the user closes a procedure, after which an internal request to transmit all of the accepted image data to one or more pre-selected remote storage AEs is generated. The Storage Client then attempts to establish an association with a remote storage AE and transmits all of the images within that one association. The Storage Client releases the association after receiving the last response from the remote storage AE.

When a storage request is generated to transmit images or X-Ray Radiation Dose SR objects from the Acquisition Workstation, the Storage Client establishes an association with a remote storage AE, requesting the Digital Mammography X-Ray Image Storage - For Processing SOP class, the Digital Mammography X-Ray Image Storage - For Presentation SOP class, the Secondary Capture Image Storage SOP class, the Breast Tomosynthesis Image Storage SOP Class, the CT Image Storage SOP Class and/or the X-Ray Radiation Dose SR Storage SOP Class. The output format is configured per remote storage AE. After the association is established a C-STORE request is made to transfer the image data objects to the remote storage AE. The Storage Client waits for each C-STORE response to be received before sending the next C-STORE request.

Note: The Secondary Capture Image Storage object is used to encapsulate Hologic 3D mammography data (Raw Projections, Processed Projections, Reconstructed Slices). Reconstructed Slices can be sent as Breast Tomosynthesis Image (preferred), Secondary Capture Image or CT Image, depending on what the remote storage AE supports.

The Acquisition Workstation may be configured to send Grayscale Softcopy Presentation State objects that contain markings/annotations created by the user immediately upon the user generating an internal request to transmit the GSPS object to one or pre-selected remote storage AEs. The Storage Client then attempts to establish an association with a remote storage AE and transmits the GSPS object. The Storage Client releases the association after receiving the response from the remote storage AE.

When a storage request is generated to transmit Grayscale Softcopy Presentation State objects from the Acquisition Workstation, the Storage Client establishes an association with a remote storage AE, requesting the Grayscale Softcopy Presentation State Storage SOP class. After the association is established a C-STORE request is made to transfer the GSPS object to the remote storage AE. The Storage Client waits for each C-STORE response to be received before sending the next C-STORE request.

3.2.4.3.1.2 Proposed Presentation Contexts

The Storage Client attempts to establish associations using the following presentation contexts:

Table 3.2.4-4

PROPOSED PRESENTATION CONTEXTS FOR ACQUIRE AND PRINT OR SEND IMAGES OR SR

Presentation Context Table					
Abstract Syntax		Transfer Syntax		Role	Extended
Name	UID	Name List	UID List		Negotiation
Digital Mammography X-Ray Image Storage – For Presentation	1.2.840.10008.5.1.4.1.1.1.2	See Table 3.2.4-5		SCU	None
Digital Mammography X-Ray Image Storage – For Processing	1.2.840.10008.5.1.4.1.1.1.2.1	See Table 3.2.4-5		SCU	None
Secondary Capture Image Storage	1.2.840.10008.5.1.4.1.1.7	See Table 3.2.4-5		SCU	None
Breast Tomosynthesis Image Storage	1.2.840.10008.5.1.4.1.1.13.1.3	See Table 3.2.4-5		SCU	None
CT Image Storage	1.2.840.10008.5.1.4.1.1.2	See Table 3.2.4-5		SCU	None
Grayscale Softcopy Presentation State Storage	1.2.840.10008.5.1.4.1.1.11.1	Explicit VR, Little Endian	1.2.840.10008.1.2.1	SCU	None
		Implicit VR, Little Endian	1.2.840.10008.1.2		
		Explicit VR, Big Endian	1.2.840.10008.1.2.2		
X-Ray Radiation Dose SR Storage	1.2.840.10008.5.1.4.1.1.88.67	Explicit VR, Little Endian	1.2.840.10008.1.2.1	SCU	None
		Implicit VR, Little Endian	1.2.840.10008.1.2		
		Explicit VR, Big Endian	1.2.840.10008.1.2.2		

Table 3.2.4-5

PROPOSED TRANSFER SYNTAXES FOR ACQUIRE AND PRINT OR SEND IMAGES OR SR

Transfer Syntax Table	
Name	UID
JPEG Lossless, Non-Hierarchical, First-Order Prediction (Process 14 [Selection Value 1]): Default Transfer Syntax for Lossless JPEG Image Compression	1.2.840.10008.1.2.4.70

Explicit VR Little Endian	1.2.840.10008.1.2.1
Implicit VR Little Endian	1.2.840.10008.1.2
Explicit VR Big Endian	1.2.840.10008.1.2.2
JPEG 2000 Image Compression (Lossless Only)	1.2.840.10008.1.2.4.90

3.2.4.3.1.3 SOP Specific Conformance for Storage

The behavior of the Acquisition Workstation when encountering status codes in a C-STORE response is summarized in the Table below.

Table 3.2.4-6

STORAGE C-STORE RESPONSE STATUS HANDLING BEHAVIOR

Service Status	Further Meaning	Error Code	Behavior
Success	Success	0000	The SCP has successfully stored the SOP Instance. Proceed to next step.
Warning	Coercion of Data Elements	B000	AWS aborts association. Error message to user indicates "A DICOM DIMSE error was returned in a response: Data element coercion"
	Data set does not match SOP Class	B007	AWS aborts association. Error message to user indicates "A DICOM DIMSE error was returned in a response: Data set does not match (warning)"
	Elements discarded	B006	AWS aborts association. Error message to user indicates "A DICOM DIMSE error was returned in a response: Elements discarded"
	Attribute list error	0107	AWS aborts association. Error message to user indicates "A DICOM DIMSE error was returned in a response: Unrecognized attribute"
Failure	Refused: Out of resources	A7xx	Upon receiving the initial error code, the AWS aborts the association. The AWS will then begin a retry strategy. When the retry strategy fails an error message to user indicates "A DICOM DIMSE error was returned in a response: Out of resources"
	Data set does not match SOP Class	A9xx	AWS aborts association. Error message to user indicates "A DICOM DIMSE error was returned in a response: Data set does not match (error)"
	Cannot understand	Cxxx	AWS aborts association. Error message to user indicates "A DICOM DIMSE error was returned in a response: Cannot understand"
	Class instance conflict	0119	AWS aborts association. Error message to user indicates "A DICOM DIMSE error was returned in a response: Class instance conflict"

The behavior of the Acquisition Workstation during communication failure is summarized in the Table below. Depending on the type of failure, and retry configuration, the send job may be retried several times before reporting an error to the user.

Table 3.2.4-7

STORAGE COMMUNICATION FAILURE BEHAVIOR

Exception	Behavior
Timeout	The Association is aborted and an error message is posted to the user: "Timeout waiting for response."
Association aborted by SCP	The error message "Unable to connect to destination host/port" is posted to the user.

Instance UIDs are globally unique for all SOP Instances generated by the Acquisition Workstation. The UID root is "1.2.840.113681."

- The Acquisition Workstation populates all Type 1 attributes with valid data and always sends them to the Remote Storage AE.
- The Acquisition Workstation sends all Type 2 attributes and populates them if valid source data are available.
- When configured the Acquisition Workstation sends Type 3, standard extended and private attributes to the Remote Storage AE and populates them if valid source data are available.

3.2.4.4 Association Acceptance Policy

The Storage Client AE does not accept associations.

3.2.5 Storage Commitment Client AE

3.2.5.1 SOP Class

This Application Entity provides Standard Conformance to the following SOP Class:

Table 3.2.5-1

SOP CLASS FOR STORAGE COMMITMENT CLIENT AE

SOP Class Name	SOP Class UID	SCU	SCP
Storage Commitment Push Model	1.2.840.10008.1.20.1	Yes	No

3.2.5.2 Association Policies

3.2.5.2.1 General

The DICOM standard Application context shall be specified.

Table 3.2.5-2

DICOM APPLICATION CONTEXT

Application Context Name	1.2.840.10008.3.1.1.1
--------------------------	-----------------------

3.2.5.2.2 Number of Associations

One association is initiated at a time for the Storage Commitment Client AE.

3.2.5.2.3 Asynchronous Nature

The Acquisition Workstation does not support asynchronous operations (multiple outstanding transactions over a single Association).

3.2.5.2.4 Implementation Identifying Information

Table 3.2.5-3

DICOM IMPLEMENTATION CLASS AND VERSION FOR STORAGE COMMITMENT CLIENT

Implementation Class UID	1.2.840.114089.1.0.0.3.3.12
Implementation Version Name	DCF 3.3.12c

3.2.5.3 Association Initiation Policy

3.2.5.3.1 Commit Images

3.2.5.3.1.1 Description and Sequencing of Activities

When the Storage Commitment Client is configured it attempts to establish an association with a remote storage commitment AE after the Storage Client receives successful C-STORE responses for one or more images. When an association is established, a N-ACTION request is sent to request storage commitment for previously stored images. The Storage Commitment Client releases the association immediately after receiving the N-ACTION response from the remote storage commitment AE.

3.2.5.3.1.2 Proposed Presentation Contexts

The Storage Commitment Client attempts to establish associations using the following presentation contexts:

Table 3.2.5-4

PROPOSED PRESENTATION CONTEXTS FOR COMMIT IMAGES

Presentation Context Table					
Abstract Syntax		Transfer Syntax		Role	Extended Negotiation
Name	UID	Name List	UID List		
Storage Commitment Push Model	1.2.840.10008.1.20.1	Implicit VR, Little Endian	1.2.840.10008.1.2	SCU	None

3.2.5.3.1.3 SOP Specific Conformance for Storage Commitment

The behavior of the Acquisition Workstation when encountering status codes in a Storage Commitment N-ACTION response is summarized in the Table below.

Table 3.2.5-5

STORAGE COMMITMENT N-ACTION RESPONSE STATUS HANDLING BEHAVIOR

Service Status	Further Meaning	Error Code	Behavior
Success	Success	0000	The request for storage comment is considered successfully sent. The commit status of each image is set to REQUESTED.
Warning	Attribute value out of range	0106	AWS aborts association. Error message to user indicates: "A DICOM DIMSE error was returned in a response. Storage Commit job failed."
Failure	Unrecognized operation	0211	AWS aborts association. Error message to user indicates: "A DICOM DIMSE error was returned in a response. Storage commit job failed."

The behavior of the Acquisition Workstation during communication failure is summarized in the Table below. Depending on the type of failure, and retry configuration, the commit job request may be retried several times before reporting an error to the user.

Table 3.2.5-6

STORAGE COMMITMENT COMMUNICATION FAILURE BEHAVIOR

Exception	Behavior
Timeout	The Association is aborted and an error message if posted to the user: "Storage Commit job was not acknowledged in the allotted time. Status of commit job is unknown."
Association aborted by SCP	The error message "Cannot open socket to specified host/port, a network error has occurred, or received abort from remote system" is posted to the user.

The Storage Commitment Client supports the following N-ACTION attributes:

Table 3.2.5-7

SUPPORTED STORAGE COMMITMENT N-ACTION ATTRIBUTES

Action Type Name	Action Type ID	Attribute	Tag	Notes
Request Storage Commitment	1	Transaction UID	(0008,1195)	Acquisition Workstation generates
		Referenced SOP Sequence	(0008,1199)	Acquisition Workstation generates, one or more Items
		> Referenced SOP Class UID	(0008,1150)	1.2.840.10008.5.1.4.1.1.1.2 or 1.2.840.10008.5.1.4.1.1.1.2.1 or 1.2.840.10008.5.1.4.1.1.7 or 1.2.840.10008.5.1.4.1.1.13.1.3 or 1.2.840.10008.5.1.4.1.1.2 or 1.2.840.10008.5.1.4.1.1.88.67
		> Referenced SOP Instance UID	(0008,1155)	Instance UID of the object to be committed

3.2.5.4 Association Acceptance Policy

3.2.5.4.1 Activity – Receive Storage Commitment Response

3.2.5.4.1.1 Description and Sequencing of Activities

The Storage Commitment Client AE will accept associations in order to receive responses to a Storage Commitment Request.

The Storage Commitment Client AE accepts a reverse role association request from a remote storage commitment AE using the Storage Commitment Push Model SOP Class. After accepting an association an N-EVENT-REPORT request is expected that provides the status of a previous request for storage commitment of an image. The Storage Commitment Client AE waits for a configurable period of time, and if a N-EVENT-REPORT request is not received, the association is aborted.

The Transaction UID value in a received N-EVENT-REPORT request is checked. SOP Instances UIDs that are successfully committed are checked and recorded. SOP Instances UIDs that are not committed are logged.

3.2.5.4.1.2 Accepted Presentation Contexts

Table 3.2.5-8

ACCEPTABLE PRESENTATION CONTEXTS FOR STORAGE COMMITMENT CLIENT AND RECEIVE STORAGE COMMITMENT RESPONSE

Presentation Context Table					
Abstract Syntax		Transfer Syntax		Role	Extended Negotiation
Name	UID	Name	UID		
Storage Commitment Push Model	1.2.840.10008.1.20.1	Implicit VR, Little Endian	1.2.840.10008.1.2	SCU	None

3.2.5.4.1.3 SOP Specific Conformance for Storage Commitment

Upon receipt of a N-EVENT-REPORT request, the commit status of the referenced images is updated, and a N-EVENT-REPORT response is sent.

The behavior of Storage Commitment Client AE when receiving Event Types within the N-EVENT-REPORT request is summarized in the Table below.

Table 3.2.5-9

STORAGE COMMITMENT N-EVENT-REPORT BEHAVIOR

Event Type Name	Event Type ID	Behavior
Storage Commitment Request Successful	1	The commit status of the Referenced SOP Instances under Referenced SOP Sequence (0008,1199) is set to ACKNOWLEDGED. Successfully committed SOP Instances are candidates for automatic deletion from the local database if local resources become scarce, unless they are otherwise protected from deletion. The conditions under which automatic deletion is initiated and the amount of space freed are site configurable.
Storage Commitment Request Complete – Failures Exist	2	The Referenced SOP Instances under Referenced SOP Sequence (0008,1199) are treated in the same way as in the success case (Event Type 1). A message is logged for each of the Referenced SOP Instances under Failed SOP Sequence (0008,1198).

The reasons for returning specific status codes in a N-EVENT-REPORT response are summarized in the Table below.

Table 3.2.5-10

STORAGE COMMITMENT N-EVENT-REPORT RESPONSE STATUS

Service Status	Further Meaning	Error Code	Reason
Success	Success	0000	

3.2.6 Query/Retrieve Client AE

3.2.6.1 SOP Classes

This Application Entity provides Standard Conformance to the following SOP Classes:

Table 3.2.6-1

SOP CLASSES FOR QUERY/RETRIEVE CLIENT AE

SOP Class Name	SOP Class UID	SCU	SCP
Study Root Query/Retrieve Information Model – FIND	1.2.840.10008.5.1.4.1.2.2.1	Yes	No
Study Root Query/Retrieve Information Model – MOVE	1.2.840.10008.5.1.4.1.2.2.2	Yes	No

3.2.6.2 Association Policies

3.2.6.2.1 General

The DICOM standard Application context shall be specified.

Table 3.2.6-2

DICOM APPLICATION CONTEXT

Application Context Name	1.2.840.10008.3.1.1.1
--------------------------	-----------------------

3.2.6.2.2 Number of Associations

One association is initiated at a time for the Query/Retrieve Client AE.

3.2.6.2.3 Asynchronous Nature

The Acquisition Workstation does not support asynchronous operations (multiple outstanding transactions over a single Association).

3.2.6.2.4 Implementation Identifying Information

Table 3.2.6-3

DICOM IMPLEMENTATION CLASS AND VERSION FOR QUERY/RETRIEVE CLIENT

Implementation Class UID	1.2.840.114089.1.0.0.3.3.12
Implementation Version Name	DCF 3.3.12c

3.2.6.3 Association Initiation Policy

3.2.6.3.1 Retrieve Prior Images

3.2.6.3.1.1 Description and Sequencing of Activities

The Query/Retrieve Client allows the user to enter matching keys that are used to query the remote Query/Retrieve AE using C-FIND operation. The Query/Retrieve Client then displays a list of patients returned in the C-FIND response until the configurable maximum is exceeded. If the maximum query response is exceeded, the user is notified and the remaining query responses are not displayed. The user may select one or more patients from the list, which signals the Query/Retrieve Client to generate a C-MOVE request(s) to the remote Query/Retrieve AE. As C-MOVE requests are successfully completed the number of remaining C-MOVE requests decrements until there are no outstanding C-MOVE requests remaining in the queue. The image data received is made available for the user to view on the Acquisition Workstation. The Query/Retrieve Client will post an alarm to the user when the C-MOVE operation fails.

The Query/Retrieve Client attempts to establish an association with a remote Query/Retrieve AE when an internal request to transmit a C-FIND or C-MOVE to a given remote Query/Retrieve AE is received. The Query/Retrieve Client releases the association after receiving the final C-FIND or C-MOVE response from the remote Query/Retrieve AE.

3.2.6.3.1.2 Proposed Presentation Contexts

The Query/Retrieve Client attempts to establish associations using the following presentation contexts:

Table 3.2.6-4

PROPOSED PRESENTATION CONTEXTS FOR RETRIEVE PRIOR IMAGES

Presentation Context Table					
Abstract Syntax		Transfer Syntax		Role	Extended
Name	UID	Name List	UID List		Negotiation
Study Root Query/Retrieve Information Model – FIND	1.2.840.10008.5.1.4.1.2.2.1	Implicit VR, Little Endian	1.2.840.10008.1.2	SCU	None
		Explicit VR, Little Endian	1.2.840.10008.1.2.1		
		Explicit VR Big Endian	1.2.840.10008.1.2.2		
Study Root Query/Retrieve Information Model – MOVE	1.2.840.10008.5.1.4.1.2.2.2	Implicit VR, Little Endian	1.2.840.10008.1.2	SCU	None
		Explicit VR, Little Endian	1.2.840.10008.1.2.1		
		Explicit VR Big Endian	1.2.840.10008.1.2.2		

3.2.6.3.1.3 SOP Specific Conformance for Query/Retrieve

The behavior of the Acquisition Workstation when encountering status codes in a C-FIND or C-MOVE response is summarized in the Table below.

*Table 3.2.6-5
C-FIND AND C-MOVE RESPONSE STATUS HANDLING BEHAVIOR*

Service Status	Further Meaning	Error Code	Behavior
Success	Matching or sub-operations are complete	0000	The SCP has successfully returned all matching information, or sub-operations are complete. For C-FIND, perform follow-up query or display results to the user.
Pending	Matches or sub-operations are continuing	FF00	For C-FIND, the matching query result contained in the Identifier is collected for later display.
Warning or Failure	Any	Any	AWS aborts association. Error message to the user indicates the Query Response Status error code, error comment, and DIMSE Status description.

The behavior of the Acquisition Workstation during communication failure is summarized in the Table below.

*Table 3.2.6-6
C-FIND AND C-MOVE COMMUNICATION FAILURE BEHAVIOR*

Exception	Behavior
Timeout	The Association is aborted and an error message is posted to the user: "Query/Retrieve not acknowledged in the allotted time."
Association aborted by SCP	The Association is aborted and any C-FIND results received before this occurs are displayed to the user. For C-MOVE, an error is indicated: "There were error(s) when pulling back the image(s): Cannot open socket to specified host/port, a network error has occurred, or received abort from remote system."

The Query/Retrieve Client provides standard conformance to the Study Root Information Model. When the hierarchical method is configured, a Study level query is sent, and the responses are used to send follow-up Series level queries automatically. For retrieve, a Series level move request is sent, containing the Study Instance UID of the study to retrieve and the Series Instance UID of the Series to retrieve. When the relational method is configured, one Study level query is sent. The relational method is not used for retrieve.

The Query/Retrieve Client supports default query Matching Key Attributes as defined in the following table. The Matching Key Attributes are contained in configuration files per Query/Retrieve provider, and can be modified as required for compatibility with remote Query/Retrieve AEs. The user supplies Matching Key Attribute values other than Modality, either by manual entry or date range selection.

*Table 3.2.6-7
SUPPORTED C-FIND MATCHING KEY ATTRIBUTES (HIERARCHICAL)*

Matching Key Attribute	Tag	Matching Type
Study Level		
Patient's Name	(0010,0010)	Wild Card Matching
Patient ID	(0010,0020)	Single Value or Wild Card Matching
Patient's Sex	(0010,0040)	Single Value
Study Date	(0008,0020)	Single Value or Range Matching
Study Time	(0008,0030)	Universal Matching
Accession Number	(0008,0050)	Universal Matching
Referring Physician's Name	(0008,0090)	Universal Matching
Study Description	(0008,1030)	Universal Matching
Study ID	(0020,0010)	Universal Matching
Study Instance UID	(0020,000D)	Universal Matching

Matching Key Attribute	Tag	Matching Type
Series Level		
Study Instance UID	(0020,000D)	Single Value Matching (from Study level result)
Series Number	(0020,0011)	Universal Matching
Series Instance UID	(0020,000E)	Universal Matching
Series Description	(0008,103E)	Universal Matching
Modality	(0008,0060)	Single Value or Wild Card Matching (MG)
Performed Procedure Step Start Date	(0040,0244)	Single Value or Range Matching
Performed Procedure Step Start Time	(0040,0245)	Universal Matching
Requested Procedure ID	(0040,1001)	Single Value or Wild Card Matching

Table 3.2.6-8

SUPPORTED C-FIND MATCHING KEY ATTRIBUTES (RELATIONAL)

Matching Key Attribute	Tag	Matching Type
Patient's Name	(0010,0010)	Wild Card Matching
Patient ID	(0010,0020)	Single Value or Wild Card Matching
Patient's Sex	(0010,0040)	Universal Matching
Study Date	(0008,0020)	Single Value or Range Matching
Study Time	(0008,0030)	Universal Matching
Accession Number	(0008,0050)	Single Matching or Universal Matching
Referring Physician's Name	(0008,0090)	Single Matching or Universal Matching
Study Instance UID	(0020,000D)	Universal Matching
Modality	(0008,0060)	Single Value or Wild Card Matching (MG)
Modalities in Study	(0008,0061)	Wild Card Matching (MG)
Series Number	(0020,0011)	Universal Matching
Series Instance UID	(0020,000E)	Universal Matching

3.2.6.4 Association Acceptance Policy

The Query/Retrieve Client AE does not accept associations.

3.2.7 Storage Server AE

3.2.7.1 SOP Classes

This Application Entity provides Standard Conformance to the following SOP Classes:

Table 3.2.7-1

SOP CLASSES FOR STORAGE SERVER AE

SOP Class Name	SOP Class UID	SCU	SCP
Digital Mammography X-Ray Image Storage – For Presentation	1.2.840.10008.5.1.4.1.1.1.2	No	Yes
Digital Mammography X-Ray Image Storage – For Processing	1.2.840.10008.5.1.4.1.1.1.2.1	No	Yes
Secondary Capture Image Storage	1.2.840.10008.5.1.4.1.1.7	No	Yes
Breast Tomosynthesis Image Storage	1.2.840.10008.5.1.4.1.1.13.1.3	No	Yes
Grayscale Softcopy Presentation State Storage	1.2.840.10008.5.1.4.1.1.11.1	No	Yes

3.2.7.2 Association Policies

3.2.7.2.1 General

The DICOM standard Application context shall be specified.

Table 3.2.7-2

DICOM APPLICATION CONTEXT

Application Context Name	1.2.840.10008.3.1.1.1
--------------------------	-----------------------

3.2.7.2.2 Number of Associations

One association is accepted at a time for the Storage Server AE.

3.2.7.2.3 Asynchronous Nature

The Acquisition Workstation does not support asynchronous operations (multiple outstanding transactions over a single Association).

3.2.7.2.4 Implementation Identifying Information

Table 3.2.7-3

DICOM IMPLEMENTATION CLASS AND VERSION FOR STORAGE SERVER

Implementation Class UID	1.2.840.114089.1.0.0.3.3.12
Implementation Version Name	DCF 3.3.12c

3.2.7.3 Association Initiation Policy

The Storage Server AE does not initiate associations.

3.2.7.4 Association Acceptance Policy

When the Storage Server AE accepts an association, it will respond to storage requests.

3.2.7.4.1 Activity – Receive Prior Images

3.2.7.4.1.1 Description and Sequencing of Activities

The Storage Server AE starts upon launching the AWS application. The Storage Server AE stores images and GSPS objects that are received so they can be made available to the user. When the AWS application receives a request to shutdown, the Storage Server AE stops running after the configurable time (in seconds) assigned to the Shutdown Wait Seconds parameter has elapsed. As a default, if a received Instance is a duplicate of an existing stored Instance, the received Instance is ignored, and the AWS sends a status of storage success in the C-STORE-RSP. However, the Storage Server AE can be configured to delete the first imported Instance of a stored object and import the duplicate Instance of the stored object or alert the user of an existing stored Instance.

3.2.7.4.1.2 Accepted Presentation Contexts

The Storage Server accepts associations using the following presentation contexts. Note: Implicit VR Little Endian is the Transfer Syntax Selenia Dimensions will accept as a default when more than one transfer syntax is proposed within a presentation context.

*Table 3.2.7-4
ACCEPTABLE PRESENTATION CONTEXTS FOR
STORAGE SERVER AND RECEIVE PRIOR IMAGES*

Presentation Context Table					
Abstract Syntax		Transfer Syntax		Role	Extended Negotiation
Name	UID	Name List	UID List		
Digital Mammography X-Ray Image Storage – For Presentation	1.2.840.10008.5.1.4.1.1.1.2	See Table 3.2.4-5		SCP	None
Digital Mammography X-Ray Image Storage – For Processing	1.2.840.10008.5.1.4.1.1.1.2.1	See Table 3.2.4-5		SCP	None
Secondary Capture Image Storage	1.2.840.10008.5.1.4.1.1.7	See Table 3.2.4-5		SCP	None
Breast Tomosynthesis Image Storage	1.2.840.10008.5.1.4.1.1.13.1.3	See Table 3.2.4-5		SCP	None
Grayscale Softcopy Presentation State Storage	1.2.840.10008.5.1.4.1.1.11.1	Implicit VR, Little Endian	1.2.840.10008.1.2	SCP	None
		Explicit VR Little Endian	1.2.840.10008.1.2.1		
		Explicit VR Big Endian	1.2.840.10008.1.2.2		

3.2.7.4.1.3 SOP Specific Conformance for Storage SOP Classes

The Storage Server AE provides standard conformance to the Storage Service Class.

Selenia Dimensions will display only Grayscale Softcopy Presentation State instances created on a SecurView 6-x or higher workstation, and a Selenia Dimensions workstation.

The Storage Server AE will behave as described in the Table below when generating the C-STORE response.

*Table 3.2.7-5
STORAGE C-STORE RESPONSE STATUS*

Service Status	Further Meaning	Error Code	Reason
Success	Success	0000	Image is stored locally and made available to the user.
Failure	Refused: Out of Resources	A7xx	There is not enough local storage capacity to store the image. Error Comment (0000,0902) is sent.
	Processing failure	0110	Any other failure. Error Comment (0000,0902) is sent containing explanation.

3.2.8 Verification AE

3.2.8.1 SOP Classes

This Application Entity provides Standard Conformance to the following SOP Class:

Table 3.2.8-1

SOP CLASS FOR VERIFICATION SCP AE

SOP Class Name	SOP Class UID	SCU	SCP
Verification SOP Class	1.2.840.10008.1.1	Yes	Yes

3.2.8.2 Association Policies

3.2.8.2.1 General

The DICOM standard Application context shall be specified.

Table 3.2.8-2

DICOM APPLICATION CONTEXT

Application Context Name	1.2.840.10008.3.1.1.1
--------------------------	-----------------------

3.2.8.2.2 Number of Associations

One association is initiated at a time for the Verification SCU. One association is accepted at a time for the Verification SCP AE.

3.2.8.2.3 Asynchronous Nature

The Acquisition Workstation does not support asynchronous operations (multiple outstanding transactions over a single Association).

3.2.8.2.4 Implementation Identifying Information

Table 3.2.8-3

DICOM IMPLEMENTATION CLASS AND VERSION FOR VERIFICATION SCP

Implementation Class UID	1.2.840.114089.1.0.0.3.3.12
Implementation Version Name	DCF 3.3.12c

3.2.8.3 Association Initiation Policy

The Verification SCU AE does initiate associations. The Verification SCP AE does not initiate associations.

3.2.8.3.1 Activity - C-ECHO

3.2.8.3.1.1 Description and Sequencing of Activities

The Acquisition Workstation provides the user with the capability to C-ECHO any remote Service Class Provider configured on the system as a virtual device.

3.2.8.3.1.2 Proposed Presentation Contexts

The SCU AE attempts to establish associations Presentation Contexts using the following Presentation Contexts.

Table 3.2.8-4

PROPOSED PRESENTATION CONTEXTS FOR ECHO REQUESTS

Presentation Context Table					
Abstract Syntax		Transfer Syntax		Role	Extended Negotiation
Name	UID	Name	UID		
Verification SOP Class	1.2.840.10008.1.1	Implicit VR, Little Endian	1.2.840.10008.1.2	SCU	None

3.2.8.3.1.3 SOP Specific Conformance for Verification SOP Class

Verification SCU provides standard conformance to the Verification Service Class. The behavior of the Acquisition Workstation when encountering status codes in a C-ECHO response is summarized in the Table below.

Table 3.2.8-5

VERIFICATION C_ECHO RESPONSE STATUS HANDLING BEHAVIOR

Service Status	Further Meaning	Error Code	Behavior
Success	Success	0000	Indicate a status of success to the user.

3.2.8.4 Association Acceptance Policy

The Verification SCU AE does not accept associations. When the Verification SCP AE accepts an association, it will respond to the verification request.

3.2.8.4.1 Activity – Receive Echo Request

3.2.8.4.1.1 Description and Sequencing of Activities

The Verification SCP is available as a service tool.

3.2.8.4.1.2 Accepted Presentation Contexts

The Verification SCP accepts associations using the following presentation contexts:

Table 3.2.8-6

ACCEPTABLE PRESENTATION CONTEXTS FOR VERIFICATION SCP AND RECEIVE ECHO REQUEST

Presentation Context Table					
Abstract Syntax		Transfer Syntax		Role	Extended Negotiation
Name	UID	Name	UID		
Verification SOP Class	1.2.840.10008.1.1	Implicit VR, Little Endian	1.2.840.10008.1.2	SCP	None
		Explicit VR Little Endian	1.2.840.10008.1.2.1		
		Explicit VR Big Endian	1.2.840.10008.1.2.2		

3.2.8.4.1.3 SOP Specific Conformance for Verification SOP Class

Verification SCP provides standard conformance to the Verification Service Class. The Verification SCP AE will behave as described in the Table below when generating the C-ECHO response.

Table 3.2.8-7

C-ECHO RESPONSE STATUS

Service Status	Further Meaning	Error Code	Reason
Success	Success	0000	Upon accepting the DICOM ASSOCIATE-RQ associated with the Verification SOP Class a status of success is sent to the

			Verification SCU.
--	--	--	-------------------

3.3 Network Interfaces

3.3.1 Physical Network Interface

The Acquisition Workstation is tested and supports using 10-BaseT, 100-BaseT and 1000-BaseT Ethernet media.

3.3.2 Additional Protocols

None.

3.4 Configuration

The DICOM Query/Retrieve, Storage, Storage Commitment, Print, Modality Performed Procedure Step and Modality Worklist Clients are configured during site installation.

A Verification SCU, used primarily as a troubleshooting tool, is made available through a service tool utility. It attempts to establish an association with a remote Verification SCP when invoked by a service tool utility.

The Verification SCP is available when the Storage AE is active. It can accept associations as a promiscuous Server or be configured to only accept the association based on the AE Title of the remote Verification SCU.

3.4.1 AE Title/Presentation Address Mapping

3.4.1.1 Local AE Titles

*Table 3.4-1
AE TITLE CONFIGURATION TABLE*

Application Entity	Default AE Title	Default TCP/IP Port
Storage Client	DIRECT_DIGXRAY	N/A
Print Client	DIRECT_DIGXRAY	N/A
Modality Worklist Client	DIRECT_DIGXRAY	N/A
Modality PPS Client	DIRECT_DIGXRAY	N/A
Storage Commitment Client	DIRECT_DIGXRAY	104
Query/Retrieve Client	DIRECT_DIGXRAY	N/A
Local Storage Server	DIRECT_DIGXRAY	104
Verification SCU	DIRECT_DIGXRAY	N/A
Verification SCP	DIRECT_DIGXRAY	104

The default AE Title and TCP/IP Port number may be modified.

3.4.1.2 Remote AE Title/Presentation Address Mapping

Up to 64 Remote Storage or Print SCPs can be configured.

3.4.1.2.1 Remote Modality Worklist SCP

The following are some of the relevant configurable items for the Remote Modality Worklist SCP:

*Table 3.4-2
REMOTE MODALITY WORKLIST SCP CONFIGURATION*

Parameter description	Range
Application Entity Title (Called AE)	The Acquisition Workstation supports multiple AEs acting as Modality Worklist provider.
Remote Host/IP Address	IP address and hostname associated with the Modality Worklist provider AE.
Remote Port Number	Port number to use when establishing TCP/IP connection to the Modality Worklist provider AE. Range = 1 to 65,535
Study Code	The attribute used to match the procedure to be performed to the procedure

Parameter description	Range
	codes available on the AWS. The available Study Code attributes include: <ul style="list-style-type: none"> • Requested Procedure Code Sequence, Code Value (0032,1064.0008,0100) • Requested Procedure Code Sequence, Code Meaning (0032,1064.0008,0104) • Scheduled Procedure Step Sequence, Scheduled Protocol Code Sequence, Code Meaning (0040,0100.0040,0008,0008,0104) • Scheduled Procedure Step Sequence, Scheduled Protocol Code Sequence, Code Value (0040,0100.0040,0008,0008,0100) • Scheduled Procedure Step Sequence, Scheduled Procedure Step Description (0040,0100.0040,0007) • Scheduled Procedure Step Sequence, Scheduled Procedure Step ID (0040,0100.0040,0009) • Study Description (0008,1030)

3.4.1.2.2 Remote MPPS SCP

The following are some of the relevant configurable items for the Remote MPPS SCP:

*Table 3.4-3
REMOTE MPPS SCP CONFIGURATION*

Parameter description	Range
Application Entity Title (Called AE)	The Acquisition Workstation supports one AE acting as a MPPS provider.
Remote Host/IP Address	IP address and hostname associated with the MPPS provider AE.
Remote Port Number	Port number to use when establishing TCP/IP connection to the MPPS provider AE. Range = 1 to 65,535
Transfer Syntax	<ul style="list-style-type: none"> • Implicit VR Little Endian or • Explicit VR Little Endian or • Explicit VR Big Endian

3.4.1.2.3 Remote Print SCP

The following are some of the relevant configurable items for each Remote Print SCP:

*Table 3.4-4
REMOTE PRINT SCP CONFIGURATION*

Parameter Description	Range
Application Entity Title (Called AE)	The Acquisition Workstation supports multiple AEs acting as Remote Print SCP.
Remote Host/IP Address	IP address and hostname, one per Remote Print AE.
Remote Port Number	Port number to use when establishing TCP/IP connection, one per Remote Print AE. Range = 1 to 65,535
Transfer Syntax	<ul style="list-style-type: none"> • Implicit VR Little Endian or • Explicit VR Little Endian or • Explicit VR Big Endian
Print Job SOP Class	<ul style="list-style-type: none"> • Enable or Disable
Presentation LUT Shape	<ul style="list-style-type: none"> • IDENTITY • LINEAR OD • INVERSE
Send Presentation LUT Info	<ul style="list-style-type: none"> • When enabled the Presentation LUT SOP Class will be negotiated

3.4.1.2.4 Remote Storage SCP

The following are some of the relevant configurable items for each Remote Storage SCP:

Table 3.4-5

REMOTE STORAGE SCP CONFIGURATION

Parameter Description	Range
Application Entity Title (Called AE)	The Acquisition Workstation supports multiple AEs acting as Remote Storage SCP.
Remote Host/IP Address	IP address and hostname, one per Remote Storage AE.
Remote Port Number	Port number to use when establishing TCP/IP connection, one per Remote Storage AE. Range = 1 to 65,535
Store IOD	<ul style="list-style-type: none"> • Digital Mammography X-Ray Image Storage - For Processing • Digital Mammography X-Ray Image Storage – For Presentation • Secondary Capture Image Storage • Breast Tomosynthesis Image Storage • CT Image Storage • Grayscale Softcopy Presentation State Storage • X-Ray Radiation Dose SR Storage
Storage Commitment	Enabled or disabled
Send from Image Acquisition	Send immediate (after each image is acquired and accepted), or wait until the procedure is closed to send all acquired and accepted images. One setting per remote storage AE.
Transfer Syntax	<ul style="list-style-type: none"> • JPEG Lossless First Order Prediction • Explicit VR Little Endian • Implicit VR Little Endian • Explicit VR Big Endian • JPEG 2000 (Lossless Only)

3.4.1.2.5 Remote Storage Commitment SCP

The following are some of the relevant configurable items for the Remote Storage Commitment SCP:

Table 3.4-6

REMOTE STORAGE COMMITMENT SCP CONFIGURATION

Parameter description	Range
Application Entity Title (Called AE)	One Remote Storage AE should be configured for storage commitment, if desired.
Remote Host/IP Address	IP address and hostname of Remote Storage Commitment AE.
Port Number	Port number to be used when establishing TCP/IP connection to the Remote Storage Commitment SCP. Range = 1 to 65,535

3.4.1.2.6 Remote Query/Retrieve SCP

The following are some of the relevant configurable items for the Remote Query/Retrieve SCP:

Table 3.4-7

Parameter description	Range
Application Entity Title (Called AE)	The Acquisition Workstation supports one AE acting as a Query/Retrieve provider.
Remote Host/IP Address	IP address and hostname associated with the Query/Retrieve provider AE.
Port Number	Port number to use when establishing TCP/IP connection to the Query/Retrieve provider AE. Range = 1 to 65,535
Transfer Syntax	<ul style="list-style-type: none"> • Implicit VR Little Endian or • Explicit VR Little Endian or • Explicit VR Big Endian
Query method	<ul style="list-style-type: none"> • Hierarchical or Relational

Parameter description	Range
Information Model	• Study Root

REMOTE QUERY/RETRIEVE SCP CONFIGURATION

3.4.2 Configuration Parameters for Local AEs

The following are some of the relevant configurable items for the local AEs:

Table 3.4-8

CONFIGURATION PARAMETERS

Parameter	Configurable (Yes/No)	Default Value
Number of seconds to wait for response to TCP/IP connect request (operating system controlled)	No	~220
ACSE PDU read timeout: Number of seconds to wait for response to an Association Open or Close Request.	Yes	30
ARTIM timeout: Number of seconds for acting SCP to wait from socket accept until Association request is read	Yes	30
Association Idle Timeout: Number of seconds of idle time allowed before an acting SCP automatically terminates an association. The idle timer runs until a complete DIMSE message is received.	Yes	180
Maximum PDU size the AE can receive	Yes, per local SCU	32,768
Maximum PDU size the AE can send (used if not negotiated). Range = 1,024 to 65,535	Yes, per local SCU	32,768
Modality Worklist Client		
Polling (On/Off)	Yes	Off
Poll period in minutes	Yes	10
MWL query timeout: Number of seconds to wait for C-FIND response	Yes	30
Maximum number of MWL items accepted	Yes	100
Matching Keys: Configured and mapped using attributes defined in section 3.2.1.3.1.3	Yes	
Return Keys: Configured and mapped using attributes defined in section 3.2.1.3.1.3	Yes	
RIS Code attribute	Yes	(0040,0100.0040,0008.0008,0100)
Modality PPS Client		
MPPS enabled	Yes	Disabled
Maximum retries	Yes	3
Radiation Dose option	Yes	False
Exception Management option	Yes	True
Discontinued Reasons	Yes	CID 9300 list
MPPS ACSE PDU read timeout: Number of seconds to wait for response to an Association Open or Close Request.	Yes	30
MPPS N-CREATE timeout: Number of seconds to wait for N-CREATE response	Yes	30
MPPS N-SET timeout: Number of seconds to wait for N-SET response	Yes	30
Print Client		
Response timeout: Number of seconds to wait for a response to any DIMSE-N command.	Yes	30
Association Control: The Print Client may be configured to control associations by: - Requesting the use of the Print Job SOP Class	Yes	Do not request Print Job
Print Job Timeout: Applies only when Print Job is requested. Number of seconds to allow after N-ACTION request is sent for DONE or FAILURE response from printer.	Yes	30
Print Job Poll Period: Applies only when Print Job is requested. Number of seconds to wait between sending alternating Printer and Print Job N-GET requests after receiving N-ACTION response. Range = 1 to 32,767	Yes	30
Retry Timer: Applies only when a Print Job is requested. Number of seconds to wait between sending another DICOM Association Request to	Yes	90

Parameter	Configurable (Yes/No)	Default Value
the Print SCP.		
Retry Counter: Applies only when a Print Job is requested. Number of attempts to establish a DICOM Association to the Print SCP.	Yes	3
Storage Client		
Response timeout: Number of seconds to wait for a C-STORE response.	Yes	3000
Retry Timer: Applies only when a Store Job is requested. Number of seconds to wait between sending another DICOM Association Request to the Store SCP.	Yes	30
Retry Counter: Applies only when a Store Job is requested. Number of attempts to establish a DICOM Association to the Store SCP.	Yes	3
Storage Commitment Client		
Response timeout: Number of seconds to wait for N-EVENT-REPORT request.	Yes	3600
Retry Timer: Applies only when a Storage Commitment Job is requested. Number of seconds to wait between sending another DICOM Association Request to the Storage Commitment SCP.	Yes	30
Retry Counter: Applies only when a Storage Commitment Job is requested. Number of attempts to establish a DICOM Association to the Storage Commitment SCP.	Yes	3
Query/Retrieve Client		
C-FIND Timeout: Number of seconds to wait for C-FIND response.	Yes	60
C-MOVE Timeout: Number of seconds to wait for C-MOVE response	Yes	600
Date Display Format:	Yes	DICOM Date Format
Max Entries: Maximum number of entries listed as a result of a query.	Yes	300
Storage Server		
Host: The IP address of the Storage Server. When it is set to 0.0.0.0 the system default IP will be used.	Yes	0.0.0.0
AE Title: The AE Title of the Storage Server	Yes	DIRECT_DIGXRAY
TCP port: Port on which the Acquisition Workstation Association Manager listens.	Yes	104
Check Calling AE Title: Will check the list of known remote AE's.	Yes	No
Maximum Concurrent Associations	Yes	8
AE Title Case Sensitive	Yes	No
Duplicate UID: determines how a duplicate SOP Instance is handled	Yes	Ignore

4.0 Media Interchange

4.1 Implementation Model

4.1.1 Application Data Flow Diagram

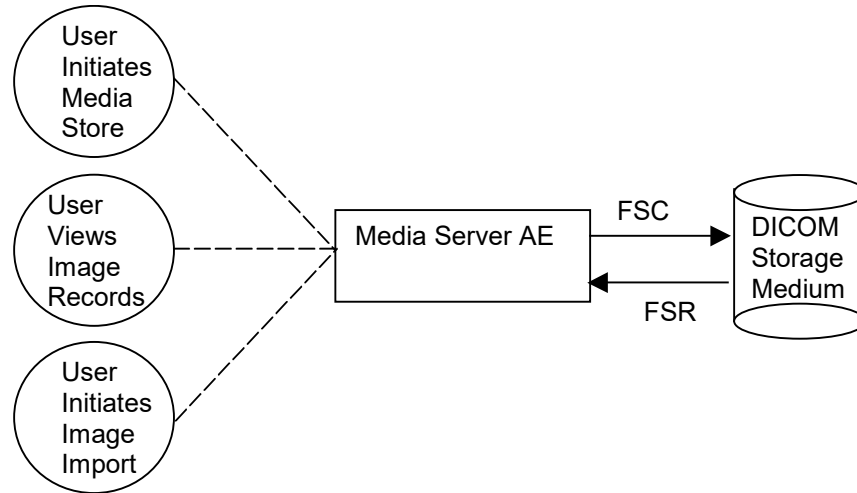

Figure 4.1-1 Application Data Flow Diagram for Media Storage

The Media Server AE provides a means to export and import Digital Mammography X-Ray Image, Secondary Capture Image, Breast Tomosynthesis Image, Grayscale Softcopy Presentation State and X-Ray Radiation Dose SR objects using DICOM PS 3.10: Media Storage and File Format for Media Interchange. The objects can be recorded and read via removable media (see Table 1-2). This feature is provided as a matter of convenience for users to move objects from one system to another via removable media. This feature is not intended to serve as an archive for permanently storing images.

4.1.2 Functional Definition of AEs

The Media Server AE can store DICOM conformant Digital Mammography X-Ray Image - For Processing, For Presentation images, Secondary Capture Image objects containing Hologic 3D mammography Raw Projections, Processed Projections and/or Reconstructed Slices, Breast Tomosynthesis Image, CT Image Storage, Grayscale Softcopy Presentation State and X-Ray Radiation Dose SR objects to removable media (see Table 1-2) as well as import those objects that have been stored on removable media (see Table 1-2) into the Acquisition Workstation database with the exception of CT Image Storage and X-Ray Radiation Dose SR. Formats for image storage are available:

- DICOM PS 3.10 format, storing images using the Digital Mammography X-Ray Image Storage – For Processing SOP Class,
- DICOM PS 3.10 format, storing images using the Digital Mammography X-Ray Image Storage – For Presentation SOP Class,
- DICOM PS 3.10 format, storing images using the Secondary Capture Image Storage SOP Class,

Note: The Media Server AE only supports Secondary Capture Image Storage SOP Class objects containing encapsulated Hologic proprietary Hologic 3D mammography data.

- DICOM PS 3.10 format, storing images using the Breast Tomosynthesis Image Storage SOP Class,
- DICOM PS 3.10 format, storing images using the CT Image Storage SOP Class,
- DICOM PS 3.10 format, storing Grayscale Softcopy Presentation State,
- DICOM PS 3.10 format, storing X-Ray Radiation Dose SR SOP Class, and
- Service utility, storing images with encrypted protected healthcare information per HIPAA guidelines.

Only the DICOM PS 3.10 format is defined in this document. For information on the service utility format, please refer to service documentation for the Selenia Dimensions Acquisition Workstation.

The Acquisition Workstation supports DICOM Media Storage as both an FSC and FSR.

4.1.3 Sequencing of Real World Activities

The Acquisition Workstation user interface provides access to configure and use removable media (see Table 1-2) as an output device to export images, GSPS objects and X-Ray Radiation Dose SR objects to removable media.

The Acquisition Workstation user interface provides access to view the content of removable media (see Table 1-2) and to select items to import from removable media to the Acquisition Workstation.

4.1.4 File Meta Information for Implementation Class Version

The implementation information written to the File Meta Header in each file is:

Table 4.1-1

DICOM IMPLEMENTATION CLASS AND VERSION FOR MEDIA STORAGE

Implementation Class UID	1.2.840.114089.1.0.0.3.3.12
Implementation Version Name	DCF 3.3.12c

4.2 AE Specifications

4.2.1 Media Server AE Specification

The Media Server AE provides standard conformance to the DICOM Interchange Option of the Media Storage Service Class. The Application Profiles and roles are listed below:

Table 4.2-1

AE RELATED APPLICATION PROFILES, REAL-WORLD ACTIVITIES, AND ROLES

Supported Application Profile	Real-World Activity	Roles
STD-GEN-CD	User Initiates Media Store	FSC
	User Views Image Records	FSR
	User Initiates Image Import	FSR
STD-GEN-DVD-JPEG	User Initiates Media Store	FSC
	User Views Image Records	FSR
	User Initiates Image Import	FSR
STD-GEN-USB-JPEG	User Initiates Media Store	FSC
	User Views Image Records	FSR
	User Initiates Image Import	FSR

4.2.1.1 File Meta Information for Media Server AE

The Source Application Entity Title included in the File Meta Header is DCF_TEST_1.

4.2.1.2 Real-World Activities

4.2.1.2.1 Activity – User Initiates Media Store

The Media Server AE acts as an FSC using the interchange option when requested to export images to removable medium such as CD-R, DVD or USB 2.0.

A Removable Media utility is available to configure what data is written to the removable media device, the format the image data is written to removable media and what image data can be imported from removable media. The removable media device is available as an output destination via the Export utility found on the Performed Exam Page (PEP).

In addition to DICOM file format images being stored and/or imported, the Media Server AE will also automatically store and/or import DICOM Grayscale Softcopy Presentation State objects. X-Ray Radiation Dose SR objects can be stored but not imported.

4.2.1.2.1.1 Media Storage Application Profile

The Media Server AE supports the STD-GEN-CD, STD-GEN-DVD-JPEG and STD-GEN-USB-JPEG Application Profiles.

4.2.1.2.1.1.1 Options

The Media Server AE supports the SOP Classes and Transfer Syntaxes listed in the Table below:

Table 4.2-2

IODS, SOP CLASSES AND TRANSFER SYNTAXES FOR MEDIA SERVER

SOP Class Name	SOP Class UID	Transfer Syntax	Transfer Syntax UID
Media Storage Directory Storage	1.2.840.10008.1.3.10	Explicit VR Little Endian	1.2.840.10008.1.2.1
Digital Mammography X-Ray Image Storage – For Presentation	1.2.840.10008.5.1.4.1.1.1.2	See Table 3.2.4-5	
Digital Mammography X-Ray Image Storage – For Processing	1.2.840.10008.5.1.4.1.1.1.2.1	See Table 3.2.4-5	
Secondary Capture Image Storage	1.2.840.10008.5.1.4.1.1.7	See Table 3.2.4-5	
Breast Tomosynthesis Image Storage	1.2.840.10008.5.1.4.1.1.13.1.3	See Table 3.2.4-5	
CT Image Storage	1.2.840.10008.5.1.4.1.1.2	See Table 3.2.4-5	
Grayscale Softcopy Presentation State Storage	1.2.840.10008.5.1.4.1.1.11.1	Explicit VR Little Endian	1.2.840.10008.1.2.1
X-Ray Radiation Dose SR Storage	1.2.840.10008.5.1.4.1.1.88.67	Explicit VR Little Endian	1.2.840.10008.1.2.1

4.2.1.2.2 Activities – User Views Image Records, User Initiates Image Import

User Views Image Records: No installation or configuration is required to view the contents of removable media (see Table 1-2). Using the Import tool found in the Admin utility, the Acquisition Workstation user can view the directory of removable media including patient, study, series, and image information.

User Initiates Image Import: Images can be imported from removable media to the Acquisition Workstation database without any special installation or configuration. The AWS can import any DICOM PS 3.10 conformant media data from the previously mentioned DICOM SOP Classes. Using the Import tool found in the Admin utility, the user can choose to import the entire media content, all images for a particular patient, a specific study, or specific image(s). A validation utility runs as part of the import process, to ensure proper identification of the patient and study.

4.2.1.2.2.1 Media Storage Application Profile

The Media Server AE supports the STD-GEN-CD, STD-GEN-DVD-JPEG and STD-GEN-USB-JPEG Application Profiles.

4.2.1.2.2.1.1 Options

The Media Server AE supports the SOP Classes and Transfer Syntaxes listed in the Table below:

Table 4.2-3

IODS, SOP CLASSES AND TRANSFER SYNTAXES FOR MEDIA SERVER

SOP Class Name	SOP Class UID	Transfer Syntax	Transfer Syntax UID
Media Storage Directory Storage	1.2.840.10008.1.3.10	Explicit VR Little Endian	1.2.840.10008.1.2.1
Digital Mammography X-Ray Image Storage – For Presentation	1.2.840.10008.5.1.4.1.1.1.2	See Table 3.2.4-5	
Digital Mammography X-Ray Image Storage – For Processing	1.2.840.10008.5.1.4.1.1.1.2.1	See Table 3.2.4-5	
Secondary Capture Image Storage	1.2.840.10008.5.1.4.1.1.7	See Table 3.2.4-5	
Breast Tomosynthesis Image Storage	1.2.840.10008.5.1.4.1.1.13.1.3	See Table 3.2.4-5	
Grayscale Softcopy Presentation State Storage	1.2.840.10008.5.1.4.1.1.11.1	Explicit VR Little Endian	1.2.840.10008.1.2.1

4.3 Augmented and Private Application Profiles

None

4.4 Media Configuration

The Media output device may be configured to store Digital Mammography X-Ray Image Storage - For Presentation or Digital Mammography X-Ray Image Storage - For Processing SOP Instances, Secondary Capture Image Storage, Breast Tomosynthesis Image Storage, CT Image Storage, Grayscale Softcopy Presentation State and X-Ray Radiation Dose SR Instances. The Media label, File-set ID (0004,1130), is configurable.

5.0 Support of Character Sets

The Acquisition Workstation supports the following character sets for the values of Data Elements with a VR of SH, LO, ST, PN or LT:

- Default:ISO-IR 6
- Latin Alphabet No. 1: ISO-IR 100

6.0 Security

The Selenia Dimensions Acquisition Workstation does not support any specific DICOM security measures.

It is assumed that the Selenia Dimensions Acquisition Workstation is used within a secured environment. It is assumed that a secured environment includes at a minimum:

- Firewall or router protections to ensure that only approved external hosts have network access to the Selenia Dimensions Acquisition Workstation.
- Firewall or router protections to ensure that the Selenia Dimensions Acquisition Workstation only has network access to approved external hosts and services.
- Any communication with external hosts and services outside the locally secured environment use appropriate secure network channels (e.g. such as a Virtual Private Network (VPN)).
- Other network security procedures such as automated intrusion detection may be appropriate in some environments. Additional security features may be established by the local security policy and are beyond the scope of this conformance statement.

7.0 Annexes

7.1 IOD Contents

7.1.1 Created SOP Instance(s)

Abbreviations for Presence of Value:

- ALWAYS Attribute always present with a value
- ANAP Attribute not always present
- EMPTY Attribute is sent without a value (zero length)
- VNAP Attribute value not always present (zero length if no value is present)

Abbreviations for Source:

- AUTO Attribute value is generated automatically
- CONFIG Attribute value source is a configurable parameter
- MWL Attribute value is the same as the value received using Modality Worklist
- USER Attribute value source is from User input

7.1.1.1 Digital Mammography X-Ray Image IOD

The default attributes that are contained in created SOP Instances are listed in the following tables. The attributes contained in created SOP Instances are configurable.

*Table 7.1-1
IOD OF CREATED DIGITAL MAMMOGRAPHY X-RAY IMAGE SOP INSTANCES*

IE	Module	Reference	Presence of Module
Patient	Patient	Table 7.1-2	ALWAYS
Study	General Study	Table 7.1-3	ALWAYS
	Patient Study	Table 7.1-4	ALWAYS
Series	General Series	Table 7.1-5	ALWAYS
	DX Series	Table 7.1-9	ALWAYS
	Mammography Series	Table 7.1-9	ALWAYS
	Frame of Reference	Table 7.1-7	ANAP
Equipment	General Equipment	Table 7.1-6	ALWAYS
Image	General Image	Table 7.1-10	ALWAYS
	Image Pixel	Table 7.1-11	ALWAYS
	Contrast/Bolus	Table 7.1-22	ANAP
	DX Anatomy Imaged	Table 7.1-12	ALWAYS
	DX Image	Table 7.1-13	ALWAYS
	DX Detector	Table 7.1-14	ALWAYS
	DX Positioning	Table 7.1-15	ALWAYS
	X-Ray Acquisition Dose	Table 7.1-16	ALWAYS
	X-Ray Generation	Table 7.1-17	ALWAYS
	X-Ray Filtration	Table 7.1-18	ALWAYS
	X-Ray Grid	Table 7.1-19	ALWAYS
	Mammography Image	Table 7.1-20	ALWAYS
	VOI LUT	See DX Image	
	Acquisition Context	Table 7.1-21	ALWAYS
	SOP Common	Table 7.1-8	ALWAYS

7.1.1.2 Common Modules

Table 7.1-2

PATIENT MODULE OF CREATED SOP INSTANCES

Attribute Name	Tag	Value	Presence of Value	Source
Patient's Name	(0010,0010)		ALWAYS	MWL, USER
Patient ID	(0010,0020)		ALWAYS	MWL, USER
Issuer of Patient ID	(0010,0021)		ANAP	MWL
Patient's Birth Date	(0010,0030)		ALWAYS	MWL, USER
Patient's Sex	(0010,0040)		VNAP	MWL, USER
Other Patient IDs	(0010,1000)		ANAP	MWL

Table 7.1-3

GENERAL STUDY MODULE OF CREATED SOP INSTANCES

Attribute Name	Tag	Value	Presence of Value	Source
Study Date	(0008,0020)		ALWAYS	AUTO
Study Time	(0008,0030)		ALWAYS	AUTO
Accession Number	(0008,0050)		VNAP	MWL, USER
Referring Physician's Name	(0008,0090)		VNAP	MWL, USER
Study Description	(0008,1030)		ALWAYS	MWL, AUTO
Referenced Study Sequence	(0008,1110)		ANAP	MWL
> Referenced SOP class UID	(0008,1150)			
> Referenced SOP Instance UID	(0008,1155)			
Study Instance UID	(0020,000D)		ALWAYS	MWL, AUTO
Study ID	(0020,0010)		ALWAYS	MWL, AUTO
Procedure Code Sequence	(0008,1032)	One item if MPPS enabled	ANAP	MWL, AUTO
> Code Value	(0008,0100)			
> Coding Scheme Designator	(0008,0102)			
> Code Meaning	(0008,0104)			

Table 7.1-4

PATIENT STUDY MODULE OF CREATED SOP INSTANCES

Attribute Name	Tag	Value	Presence of Value	Source
Patient's Age	(0010,1010)	Calculated from (0010,0030). Based on the age of the patient when the study was performed	ALWAYS	AUTO
Patient's Weight	(0010,1030)	Contrast only	ANAP	USER

Table 7.1-5

GENERAL SERIES MODULE OF CREATED SOP INSTANCES

Attribute Name	Tag	Value	Presence of Value	Source
Modality	(0008,0060)	See Table 7.1-9		
Series Instance UID	(0020,000E)	Unique value generated by AWS	ALWAYS	AUTO
Series Number	(0020,0011)	Note: The components of this value are as follows: wxx00000 w = Hologic identifier [7] xx = image type For Processing = 10, For Presentation = 11 For Processing Combo = 12 For Presentation Combo or C-View 2D = 13 For Processing high energy = 15 For Presentation subtraction = 16	ALWAYS	AUTO
Series Date	(0008,0021)		ALWAYS	AUTO
Series Time	(0008,0031)		ALWAYS	AUTO
Protocol Name	(0018,1030)	Laterality and projection view	ALWAYS	AUTO
Series Description	(0008,103E)	Same as (0018,1030) Note: Biopsy images have the stereo identifier appended Note: C-View 2D images have 'C-View' appended Note: Contrast images have '(LE)', '(HE)', or '(DES)' appended	ALWAYS	AUTO
Operators' Name	(0008,1070)		ALWAYS	AUTO
Body Part Examined	(0018,0015)	BREAST	ALWAYS	AUTO
Request Attributes Sequence	(0040,0275)	Present only for image objects resulting from scheduled procedure steps	ANAP	AUTO
> Requested Procedure ID	(0040,1001)		ANAP	MWL
>Requested Procedure Description	(0032,1060)		ANAP	MWL
>Reason for Requested Procedure Code Sequence	(0040,100A)		ANAP	MWL
>>Code Value	(0008,0100)			
>>Coding Scheme Designator	(0008,0102)			
>>Code Meaning	(0008,0104)			
> Scheduled Procedure Step ID	(0040,0009)		ANAP	MWL
> Scheduled Procedure Step Description	(0040,0007)		ANAP	MWL
> Scheduled Protocol Code Sequence	(0040,0008)		ANAP	MWL
>> Code Value	(0008,0100)			
>> Coding Scheme Designator	(0008,0102)			
>> Code Meaning	(0008,0104)			
Performed Procedure Step ID	(0040,0253)		ALWAYS	AUTO
Performed Procedure Step Start Date	(0040,0244)	Date first image acquired	ALWAYS	AUTO

Attribute Name	Tag	Value	Presence of Value	Source
Performed Procedure Step Start Time	(0040,0245)	Time first image acquired	ALWAYS	AUTO
Performed Procedure Step Description	(0040,0254)		ALWAYS	AUTO
Performed Protocol Code Sequence	(0040,0260)	One Item	ANAP	AUTO
> Code Value	(0008,0100)			
> Coding Scheme Designator	(0008,0102)			
> Code Meaning	(0008,0104)			

Table 7.1-6

GENERAL EQUIPMENT MODULE OF CREATED SOP INSTANCES

Attribute Name	Tag	Value	Presence of Value	Source
Manufacturer	(0008,0070)	HOLOGIC, Inc.	ALWAYS	CONFIG
Institution Name	(0008,0080)		ALWAYS	CONFIG
Institution Address	(0008,0081)		ALWAYS	CONFIG
Station Name	(0008,1010)		ALWAYS	CONFIG
Institutional Department Name	(0008,1040)		ALWAYS	CONFIG
Manufacturer's Model Name	(0008,1090)	Selenia Dimensions	ALWAYS	CONFIG
Device Serial Number	(0018,1000)		ALWAYS	AUTO
Software Versions	(0018,1020)		ALWAYS	AUTO
Date of Last Calibration	(0018,1200)	Only in 2D images	ANAP	AUTO
Time of Last Calibration	(0018,1201)	Only in 2D images	ANAP	AUTO
Pixel Padding Value	(0028,0120)	0 Note: Not included in Dose SR	ALWAYS	AUTO

Table 7.1-7

FRAME OF REFERENCE MODULE OF CREATED SOP INSTANCES

Attribute Name	Tag	Value	Presence of Value	Source
Frame of Reference UID	(0020,0052)	Unique value generated by AWS Note: 2D biopsy images have the same frame of reference for a scout and subsequent non-scout images under the same compression. Note: C-View 2D has the same frame of reference as the corresponding Hologic 3D mammography projection images, reconstructed slices, and 2D image if the procedure is a Combo. Note: Contrast images acquired and derived from the same compression have the same frame of reference	ANAP	AUTO
Position Reference Indicator	(0020,1040)		EMPTY	AUTO

Table 7.1-8

SOP COMMON MODULE OF CREATED SOP INSTANCES

Attribute Name	Tag	Value	Presence of Value	Source
Instance Creator UID	(0008,0014)	Note: Not included in Dose SR	ALWAYS	AUTO
SOP Class UID	(0008,0016)	UID for Digital Mammography X-ray Image Storage – For Presentation (includes C-View 2D) or For Processing, Secondary Capture Image Storage, Breast Tomosynthesis Image Storage (includes C-View 2D), CT Image Storage or X-Ray Radiation Dose SR Storage	ALWAYS	AUTO
SOP Instance UID	(0008,0018)	Unique value generated by AWS	ALWAYS	AUTO
Specific Character Set	(0008,0005)	ISO_IR 100	ALWAYS	AUTO
Instance Number	(0020,0013)	See Table 7.1-10		

7.1.1.3 Digital Mammography X-Ray Image Modules

Table 7.1-9

DX SERIES / MAMMOGRAPHY SERIES MODULE OF CREATED SOP INSTANCES

Attribute Name	Tag	Value	Presence of Value	Source
Modality	(0008,0060)	MG	ALWAYS	AUTO
Presentation Intent Type	(0008,0068)	Original image: "FOR PROCESSING" Derived image: "FOR PRESENTATION" Note: C-View 2D is "FOR PRESENTATION" only	ALWAYS	AUTO
Referenced Performed Procedure Step Sequence	(0008,1111)	One Item if MPPS enabled	ANAP	AUTO
>Referenced SOP Class UID	(0008,1150)	MPPS SOP Class UID		
>Referenced SOP Instance UID	(0008,1155)			

Table 7.1-10

GENERAL IMAGE MODULE OF CREATED SOP INSTANCES

Attribute Name	Tag	Value	Presence of Value	Source
Instance Number	(0020,0013)		ALWAYS	AUTO
Patient Orientation	(0020,0020)	See Table 7.1-13		
Content Date	(0008,0023)	Same as Acquisition Date (0008,0022)	ALWAYS	AUTO
Content Time	(0008,0033)	Same as Acquisition Time (0008,0032)	ALWAYS	AUTO
Image Type	(0008,0008)	See Table 7.1-13		
Acquisition Date	(0008,0022)	Note: Not included in C-View 2D	ALWAYS	AUTO
Acquisition Time	(0008,0032)	Note: Not included in C-View 2D	ALWAYS	AUTO
Referenced Image Sequence	(0008,1140)	One Item for stereo paired biopsy images One Item for contrast subtraction image	ANAP	AUTO

Attribute Name	Tag	Value	Presence of Value	Source
>Referenced SOP Class UID	(0008,1150)			
>Referenced SOP Instance UID	(0008,1151)	Biopsy: SOP Instance UID of the stereo paired image Contrast: SOP Instance UID of the low energy image		
>Purpose of Reference Code Sequence	(0040,a170)	Biopsy: One Item containing (121315, DCM, "Other image of stereoscopic pair") Contrast: One Item containing (121339, DCM, "Functional image")		
Source Image Sequence	(0008,2112)	Original image: references original image if re-previewed and saved Derived image: references the FOR PROCESSING image, plus references previous image if re-previewed and saved C-View 2D image: references the source Raw C-View image Contrast image: subtraction image references the low energy and high energy FOR PROCESSING images	ANAP	AUTO
> Referenced SOP Class UID	(0008,1150)	Derived 2D, Contrast: 1.2.840.10008.5.1.4.1.1.1.2.1 C-View 2D: 1.2.840.10008.5.1.4.1.1.7		
> Referenced SOP Instance UID	(0008,1155)			
>Purpose of Referenced Code Sequence	(0040,A170)	One Item containing (121322, DCM, "Source image for image processing operation")	ANAP	AUTO
>Spatial Locations Preserved	(0028,135A)	YES Note: C-View 2D = YES	ANAP	AUTO
Irradiation Event UID	(0008,3010)		ALWAYS	AUTO
Derivation Code Sequence	(0008,9215)	Contrast only, one Item in subtraction image containing (113062, DCM, "Pixel by pixel subtraction")	ANAP	AUTO
Images in Acquisition	(0020,1002)	1 Note: Not included in C-View 2D	ALWAYS	AUTO
Image Comments	(0020,4000)	User enters manually or selects from list	ANAP	USER
Quality Control Image	(0028,0300)	YES or NO	ALWAYS	AUTO
Burned in Annotation	(0028,0301)	See Table 7.1-13		
Lossy Image Compression	(0028,2110)	See Table 7.1-13		

Table 7.1-11

IMAGE PIXEL MODULE OF CREATED SOP INSTANCES

Attribute Name	Tag	Value	Presence of Value	Source
Samples per Pixel	(0028,0002)	See Table 7.1-13		
Photometric Interpretation	(0028,0004)	See Table 7.1-13		
Rows	(0028,0010)	3328 (18x24 Paddle) 4096 (24x29 Paddle) 2457 (C-View 2D)	ALWAYS	AUTO
Columns	(0028,0011)	2560 (18x24 Paddle) 3328 (24x29 Paddle) 1890 (C-View 2D small paddle) 1996 (C-View 2D large paddle)	ALWAYS	AUTO
Bits Allocated	(0028,0100)	See Table 7.1-13		
Bits Stored	(0028,0101)	See Table 7.1-13		
High Bit	(0028,0102)	See Table 7.1-13		
Pixel Representation	(0028,0103)	See Table 7.1-13		
Pixel Padding Range Limit	(0028,0121)	C-View 2D: 4 Note: Not included in acquired 2D images.	ALWAYS	AUTO
Pixel Data	(7FE0,0010)		ALWAYS	AUTO

Table 7.1-12

DX ANATOMY IMAGED MODULE OF CREATED SOP INSTANCES

Attribute Name	Tag	Value	Presence of Value	Source
The supported attributes are overridden by the Mammography Image module. See Table 7.1-20.				

Table 7.1-13

DX IMAGE MODULE OF CREATED SOP INSTANCES

Attribute Name	Tag	Value	Presence of Value	Source
Image Type	(0008,0008)	Original: ORIGINAL\PRIMARY\value 3 Derived: DERIVED\PRIMARY\value 3 Where value 3 is one of: empty (non-biopsy), STEREO_SCOUT, STEREO_MINUS, STEREO_PLUS, PREFIRE_MINUS, PREFIRE_PLUS, POSTFIRE_MINUS, POSTFIRE_PLUS, POSTBIOPSY_MINUS, POSTBIOPSY_PLUS, POSTBIOPSY, POSTMARKER_MINUS, POSTMARKER_PLUS, POSTMARKER Where value 4 is one of: absent (non-contrast), CONTRAST_IMAGE, LOW_E_PRE_CON, LOW_E_POST_CON	ALWAYS	AUTO
Samples per Pixel	(0028,0002)	1	ALWAYS	AUTO
Photometric Interpretation	(0028,0004)	Original image: MONOCHROME1 (Minimum pixels = white) Derived image: MONOCHROME2 (Minimum pixels = black)	ALWAYS	AUTO
Bits Allocated	(0028,0100)	16	ALWAYS	AUTO
Bits Stored	(0028,0101)	Original image: 14 Derived image: 12 C-View 2D image: 10	ALWAYS	AUTO
High Bit	(0028,0102)	Original image: 13 Derived image: 11 C-View 2D image: 9	ALWAYS	AUTO
Pixel Representation	(0028,0103)	0000H	ALWAYS	AUTO
Pixel Intensity Relationship	(0028,1040)	Original image: LIN Derived image: LOG	ALWAYS	AUTO
Pixel Intensity Relationship Sign	(0028,1041)	Original image: 1 Derived image: -1	ALWAYS	AUTO
Rescale Intercept	(0028,1052)	0	ALWAYS	AUTO
Rescale Slope	(0028,1053)	1	ALWAYS	AUTO
Rescale Type	(0028,1054)	US	ALWAYS	AUTO
Presentation LUT Shape	(2050,0020)	Original image: INVERSE Derived image: IDENTITY	ALWAYS	AUTO
Lossy Image Compression	(0028,2110)	00	ALWAYS	AUTO
Patient Orientation	(0020,0020)	2D and C-View 2D pixel data orientation can be configured to match the user selected hanging protocol (dorsal or ventral).	ALWAYS	AUTO, USER
Burned in Annotation	(0028,0301)	NO	ALWAYS	AUTO
Window Center	(0028,1050)	2047 C-View 2D: 540	ANAP	AUTO
Window Width	(0028,1051)	4096 C-View 2D: 580	ANAP	AUTO

Table 7.1-14

DX DETECTOR MODULE OF CREATED SOP INSTANCES

Attribute Name	Tag	Value	Presence of Value	Source
Detector Type	(0018,7004)	DIRECT	ALWAYS	AUTO
Detector ID	(0018,700A)		ALWAYS	AUTO
Date of Last Detector Calibration	(0018,700C)	Same as (0018,1200)	ALWAYS	AUTO
Time of Last Detector Calibration	(0018,700E)	Same as (0018,1201)	ALWAYS	AUTO
Detector Binning	(0018,701A)	1\1 for 2D 2\2 for C-View 2D	ALWAYS	AUTO
Detector Conditions Nominal Flag	(0018,7000)	YES Note: Not included in C-View 2D	ALWAYS	AUTO
Detector Temperature	(0018,7001)		ALWAYS	AUTO
Field of View Origin	(0018,7030)		ALWAYS	AUTO
Field of View Rotation	(0018,7032)		ALWAYS	AUTO
Field of View Horizontal Flip	(0018,7034)		ALWAYS	AUTO
Imager Pixel Spacing	(0018,1164)	.70\70 Note: C-View 2D values are based on image processing, to match corresponding reconstructed slices	ALWAYS	AUTO
Pixel Spacing	(0028,0030)	Depends on magnification factor	ALWAYS	AUTO

Table 7.1-15

DX POSITIONING MODULE OF CREATED SOP INSTANCES

Attribute Name	Tag	Value	Presence of Value	Source
View Position	(0018,5101)	User selects view to acquire	ALWAYS	AUTO, USER
View Code Sequence	(0054,0220)	See Table 7.1-20		
Distance Source to Detector	(0018,1110)		ALWAYS	AUTO
Distance Source to Patient	(0018,1111)		ALWAYS	AUTO
Estimated Radiographic Magnification Factor	(0018,1114)	Non-Mag Images: 1.073 default Mag Images: 1.5 or, 1.8 or, 2.0 C-View 2D Images: 1	ALWAYS	AUTO
Positioner Type	(0018,1508)	See Table 7.1-20		
Positioner Primary Angle	(0018,1510)	See Table 7.1-20		
Body Part Thickness	(0018,11A0)	From x-ray system	ALWAYS	AUTO
Compression Force	(0018,11A2)	From x-ray system	ALWAYS	AUTO
Paddle Description	(0018,11A4)	From x-ray system	ALWAYS	AUTO

*Table 7.1-16
X-RAY ACQUISITION DOSE MODULE OF CREATED SOP INSTANCES*

Attribute Name	Tag	Value	Presence of Value	Source
KVP	(0018,0060)	See Table 7.1-17		
X-Ray Tube Current	(0018,1151)	See Table 7.1-17		
Exposure Time	(0018,1150)	See Table 7.1-17		
Exposure	(0018,1152)	See Table 7.1-17		
Exposure in uAs	(0018,1153)	From x-ray system	ALWAYS	AUTO
Exposure Time in µS	(0018,8150)	From x-ray system	ALWAYS	AUTO
Distance Source to Detector	(0018,1110)	See Table 7.1-15		
Distance Source to Patient	(0018,1111)	See Table 7.1-15		
Body Part Thickness	(0018,11A0)	See Table 7.1-15		
Entrance Dose	(0040,0302)	Note: Not included in C-View 2D	ALWAYS	AUTO
Entrance Dose in mGy	(0040,8302)	Note: Not included in C-View 2D	ALWAYS	AUTO
Half Value Layer	(0040,0314)		ALWAYS	AUTO
Organ Dose	(0040,0316)	Note: Not included in C-View 2D	ALWAYS	AUTO
Organ Exposed	(0040,0318)	See Table 7.1-20		
Anode Target Material	(0018,1191)	See Table 7.1-17		
Filter Type	(0018,1160)	STRIP	ALWAYS	AUTO
Filter Material	(0018,7050)	ALUMINIUM COPPER LEAD MOLYBDENUM RHODIUM SILVER TIN	ALWAYS	AUTO
Filter Thickness Minimum	(0018,7052)		ALWAYS	AUTO
Filter Thickness Maximum	(0018,7054)		ALWAYS	AUTO
Relative X-Ray Exposure	(0018,1405)		ALWAYS	AUTO

*Table 7.1-17
X-RAY GENERATION MODULE OF CREATED SOP INSTANCES*

Attribute Name	Tag	Value	Presence of Value	Source
KVP	(0018,0060)	From x-ray system	ALWAYS	AUTO
X-ray Tube Current	(0018,1151)	From x-ray system	ALWAYS	AUTO
Exposure Time	(0018,1150)	From x-ray system	ALWAYS	AUTO
Exposure	(0018,1152)	From x-ray system	ALWAYS	AUTO
Focal Spot(s)	(0018,1190)		ALWAYS	AUTO
Anode Target Material	(0018,1191)	MOLYBDENUM RHODIUM TUNGSTEN	ALWAYS	AUTO
Exposure Control Mode	(0018,7060)	MANUAL TEC AUTO_KV AUTO_TIME AUTO_FILTER	ALWAYS	AUTO
Exposure Control Mode Description	(0018,7062)	MANUAL TEC LORAD AEC SENSOR POSITION x LORAD AUTO AEC	ALWAYS	AUTO

Table 7.1-18

X-RAY FILTRATION MODULE OF CREATED SOP INSTANCES

Attribute Name	Tag	Value	Presence of Value	Source
The supported attributes are listed in the X-ray Acquisition Dose module. See Table 7.1-16.				

Table 7.1-19

X-RAY GRID MODULE OF CREATED SOP INSTANCES

Attribute Name	Tag	Value	Presence of Value	Source
Grid	(0018,1166)	IN, NONE	ALWAYS	AUTO

Table 7.1-20

MAMMOGRAPHY IMAGE MODULE OF CREATED SOP INSTANCES

Attribute Name	Tag	Value	Presence of Value	Source
Positioner Type	(0018,1508)	MAMMOGRAPHIC	ALWAYS	AUTO
Positioner Primary Angle	(0018,1510)		ALWAYS	AUTO
Image Laterality	(0020,0062)	R, L	ALWAYS	AUTO, USER
Organ Exposed	(0040,0318)	BREAST	ALWAYS	AUTO
Breast Implant Present	(0028,1300)	YES, NO	ALWAYS	AUTO, USER
Anatomic Region Sequence	(0008,2218)	One Item containing (T-04000, SNM3, "Breast")	ALWAYS	AUTO
View Code Sequence	(0054,0220)	One Item from CID 4014: CC, MLO, LM, ML, LMO, SIO, ISO, FB, XCCL, XCCM	ALWAYS	AUTO, USER
> Code Value	(0008,0100)			
> Code Scheme Designator	(0008,0102)			
> Code Meaning	(0008,0104)			
>View Modifier Code Sequence	(0054,0222)	Zero or more Items from CID 4015: M, S, RL, RM, CV, AT, TAN, ID, RI, RS, NP, AC, IMF,AX (M)agnification and/or (S)pot compression is based on the compression paddle	VNAP	AUTO, USER
>> Code Value	(0008,0100)			
>> Code Scheme Designator	(0008,0102)			
>> Code Meaning	(0008,0104)			
Biopsy Target Sequence	(0018,2041)	Biopsy only. One or more Items if target(s) added	ANAP	AUTO, USER
>Target UID	(0018,2042)			
>Localizing Cursor Position	(0018,2043)			
>Calculated Target Position	(0018,2044)			
>Displayed Z Value	(0018,2046)			

Table 7.1-21

ACQUISITION CONTEXT MODULE OF CREATED SOP INSTANCES

Attribute Name	Tag	Value	Presence of Value	Source
Acquisition Context Sequence	(0040,0555)		EMPTY	AUTO

Table 7.1-22

CONTRAST/BOLUS MODULE OF CREATED SOP INSTANCES

Attribute Name	Tag	Value	Presence of Value	Source
Contrast/Bolus Agent	(0018,0010)	Contrast only	ANAP	USER
Contrast/Bolus Agent Sequence	(0018,0012)	Contrast only, one Item	ANAP	USER
> Code Value	(0008,0100)			
> Code Scheme Designator	(0008,0102)			
> Code Meaning	(0008,0104)			
Contrast/Bolus Route	(0018,1040)	Contrast only	ANAP	USER
Contrast/Bolus Administration Route Sequence	(0018,0014)	Contrast only, one Item	ANAP	USER
> Code Value	(0008,0100)			
> Code Scheme Designator	(0008,0102)			
> Code Meaning	(0008,0104)			
Contrast/Bolus Volume	(0018,1041)	Contrast only	ANAP	USER
Contrast/Bolus Start Time	(0018,1042)	Contrast only	ANAP	USER
Contrast/Bolus Total Dose	(0018,1044)	Contrast only	ANAP	USER
Contrast/Bolus Ingredient	(0018,1048)	Contrast only Default = IODINE	ANAP	CONFIG
Contrast/Bolus Ingredient Concentration	(0018,1049)	Contrast only	ANAP	USER

7.1.1.4 Secondary Capture Image IOD

The default attributes that are contained in created SOP Instances are listed in the following tables. The attributes contained in created SOP Instances are configurable.

Table 7.2-1

IOD OF CREATED SECONDARY CAPTURE IMAGE SOP INSTANCES

IE	Module	Reference	Presence of Module
Patient	Patient	Table 7.1-2	ALWAYS
Study	General Study	Table 7.1-3	ALWAYS
	Patient Study	Table 7.1-4	ALWAYS
Series	General Series	Table 7.2-2	ALWAYS
Equipment	General Equipment	Table 7.1-6	ALWAYS
	SC Equipment	Table 7.2-3	ALWAYS
Image	General Image	Table 7.2-4	ALWAYS
	Image Pixel	Table 7.2-5	ALWAYS
	SC Image		ANAP (optional attributes, not included)
	VOI LUT	Table 7.2-6	ALWAYS
	SOP Common	Table 7.1-8	ALWAYS

7.1.1.5 Secondary Capture Image Modules

Table 7.2-2

GENERAL SERIES MODULE OF CREATED SOP INSTANCES

Attribute Name	Tag	Value	Presence of Value	Source
Modality	(0008,0060)	MG	ALWAYS	AUTO
Series Instance UID	(0020,000E)	Unique value generated by AWS	ALWAYS	AUTO
Series Number	(0020,0011)	Note: The components of this value are as follows: wxx00000 w = Hologic identifier [7] xx = image type Raw Projections = 20 Display Projections = 21 Reconstructed Slices = 31	ALWAYS	AUTO
Laterality	(0020,0060)	L or R	ALWAYS	AUTO, USER
Series Date	(0008,0021)		ALWAYS	AUTO
Series Time	(0008,0031)		ALWAYS	AUTO
Protocol Name	(0018,1030)	Laterality and projection view	ALWAYS	AUTO
Series Description	(0008,103E)	Same as (0018,1030) appended with type of image (projection, reconstruction, biopsy identifier)	ALWAYS	AUTO
Operators' Name	(0008,1070)		ALWAYS	AUTO
Referenced Performed Procedure Step Sequence	(0008,1111)	One Item if MPPS enabled	ANAP	AUTO
>Referenced SOP Class UID	(0008,1150)	MPPS SOP Class UID		
>Referenced SOP Instance UID	(0008,1155)			
Related Series Sequence	(0008,1250)	One Item in processed projections and reconstructed slices	ANAP	AUTO
>Study Instance UID	(0020,000D)	Same as (0020,000D) at top level		
>Series Instance UID	(0020,000E)	Processed projections reference reconstructed slices value and vice versa		
>Purpose of Reference Code Sequence	(0040,A170)	One Item containing (122400, DCM, "Simultaneously Acquired")		
Body Part Examined	(0018,0015)	BREAST	ALWAYS	AUTO
Request Attributes Sequence	(0040,0275)	Present only for image objects resulting from scheduled procedure steps	ANAP	AUTO
> Requested Procedure ID	(0040,1001)		ANAP	MWL
>Requested Procedure Description	(0032,1060)		ANAP	MWL
>Reason for Requested Procedure Code Sequence	(0040,100A)		ANAP	MWL
>>Code Value	(0008,0100)			
>>Coding Scheme Designator	(0008,0102)			
>>Code Meaning	(0008,0104)			
> Scheduled Procedure Step ID	(0040,0009)		ANAP	MWL
> Scheduled Procedure Step Description	(0040,0007)		ANAP	MWL
> Scheduled Protocol Code Sequence	(0040,0008)		ANAP	MWL
>> Code Value	(0008,0100)			
>> Coding Scheme Designator	(0008,0102)			

Attribute Name	Tag	Value	Presence of Value	Source
>> Code Meaning	(0008,0104)			
Performed Procedure Step ID	(0040,0253)		ALWAYS	AUTO
Performed Procedure Step Start Date	(0040,0244)	Date first image acquired	ALWAYS	AUTO
Performed Procedure Step Start Time	(0040,0245)	Time first image acquired	ALWAYS	AUTO
Performed Procedure Step Description	(0040,0254)		ALWAYS	AUTO
Performed Protocol Code Sequence	(0040,0260)		ANAP	AUTO
> Code Value	(0008,0100)			
> Coding Scheme Designator	(0008,0102)			
> Code Meaning	(0008,0104)			

Table 7.2-3

SC EQUIPMENT MODULE OF CREATED SOP INSTANCES

Attribute Name	Tag	Value	Presence of Value	Source
Conversion Type	(0008,0064)	WSD	ALWAYS	AUTO

Table 7.2-4

GENERAL IMAGE MODULE OF CREATED SOP INSTANCES

Attribute Name	Tag	Value	Presence of Value	Source
Instance Number	(0020,0013)		ALWAYS	AUTO
Patient Orientation	(0020,0020)	Reconstructed slices pixel data orientation can be configured to match the user selected hanging protocol (dorsal or ventral). Projections: When the patient is upright, P\L for CC, P\R for FB, P\H when the C-arm is approaching the patient's right (+90), P\F when the C-arm is approaching the patient's left (-90)	ALWAYS	AUTO
Content Date	(0008,0023)	Same as Acquisition Date (0008,0022)	ALWAYS	AUTO
Content Time	(0008,0033)	Same as Acquisition Time (0008,0032)	ALWAYS	AUTO
Image Type	(0008,0008)	ORIGINAL\PRIMARY\value 3 or DERIVED\PRIMARY\value 3 Where value 3 is one of: absent (non-biopsy), TOMO_SCOUT, POSTBIOPSY	ALWAYS	AUTO
Acquisition Date	(0008,0022)		ALWAYS	AUTO
Acquisition Time	(0008,0032)		ALWAYS	AUTO
Source Image Sequence	(0008,2112)	The DERIVED\PRIMARY SC Image object references the ORIGINAL\PRIMARY SC Image object.	ALWAYS	AUTO
> Referenced SOP Class UID	(0008,1150)	1.2.840.10008.5.1.4.1.1.7	ALWAYS	AUTO

Attribute Name	Tag	Value	Presence of Value	Source
> Referenced SOP Instance UID	(0008,1155)	The SOP Instance UID of the Raw Projection data object	ALWAYS	AUTO
>Purpose of Referenced Code Sequence	(0040,A170)	One Item containing (121322, DCM, "Source image for image processing operation")	ALWAYS	AUTO
>Spatial Locations Preserved	(0028,135A)	NO	ALWAYS	AUTO
Irradiation Event UID	(0008,3010)		ALWAYS	AUTO
Images in Acquisition	(0020,1002)	Raw Projections = 15 Displayed Projections = 15 Reconstructed Slices = based on the thickness of the breast.	ALWAYS	AUTO
Image Comments	(0020,4000)	User enters manually or selects from list	ANAP	USER
Burned in Annotation	(0028,0301)	NO	ALWAYS	AUTO
Lossy Image Compression	(0028,2110)	00	ALWAYS	AUTO
Presentation LUT Shape	(2050,0020)	IDENTITY	ALWAYS	AUTO

Table 7.2-5

IMAGE PIXEL MODULE OF CREATED SOP INSTANCES

Attribute Name	Tag	Value	Presence of Value	Source
Samples per Pixel	(0028,0002)	1	ALWAYS	AUTO
Photometric Interpretation	(0028,0004)	MONOCHROME2	ALWAYS	AUTO
Rows	(0028,0010)	425	ALWAYS	AUTO
Columns	(0028,0011)	266	ALWAYS	AUTO
Bits Allocated	(0028,0100)	16	ALWAYS	AUTO
Bits Stored	(0028,0101)	10	ALWAYS	AUTO
High Bit	(0028,0102)	9	ALWAYS	AUTO
Pixel Representation	(0028,0103)	0	ALWAYS	AUTO
Pixel Padding Range Limit	(0028,0121)	4	ALWAYS	AUTO
Pixel Data	(7FE0,0010)	Contains interoperable data for the center projection or middle reconstructed slice. The pixel data for the projection images or reconstructed slices is encoded in private attributes (7E01,10xx) in a proprietary compressed format. The size of the private data varies based on the habitus of the patient.	ALWAYS	AUTO

Table 7.2-6

VOI LUT MODULE OF CREATED SOP INSTANCES

Attribute Name	Tag	Value	Presence of Value	Source
Window Center	(0028,1050)	Projections = 480 Reconstructed Slices = 512	ALWAYS	AUTO
Window Width	(0028,1051)	Projections = 380 Reconstructed Slices = 512	ALWAYS	AUTO

7.1.1.6 Breast Tomosynthesis Image IOD

The attributes that are contained in created Breast Tomosynthesis Image Instances are listed in the following tables.

*Table 7.3-1
IOD OF CREATED BREAST TOMOSYNTHESIS IMAGE INSTANCES*

IE	Module	Reference	Presence of Module
Patient	Patient	Table 7.1-2	ALWAYS
Study	General Study	Table 7.1-3	ALWAYS
	Patient Study	Table 7.1-4	ALWAYS
Series	General Series	Table 7.3-2	ALWAYS
	Enhanced Mammography Series	Table 7.3-2	ALWAYS
Frame of Reference	Frame of Reference	Table 7.1-7	ALWAYS (UID: ALWAYS)
Equipment	General Equipment	Table 7.1-6	ALWAYS
	Enhanced General Equipment	Table 7.1-6	ALWAYS
Image	Image Pixel	Table 7.3-3	ALWAYS
	Acquisition Context	Table 7.1-21	ALWAYS
	Multi-frame Functional Groups	Table 7.3-4	ALWAYS
	X-Ray 3D Image	Table 7.3-3	ALWAYS
	Breast Tomosynthesis Contributing Sources	Table 7.3-5	ALWAYS
	Breast Tomosynthesis Acquisition	Table 7.3-6	ALWAYS
	Breast View	Table 7.3-7	ALWAYS
	SOP Common	Table 7.1-8	ALWAYS

7.1.1.7 Breast Tomosynthesis Image Modules

*Table 7.3-2
SERIES MODULES OF CREATED BREAST TOMOSYNTHESIS IMAGE INSTANCES*

Attribute Name	Tag	Value	Presence of Value	Source
Series Date	(0008,0021)		ALWAYS	AUTO
Series Time	(0008,0031)		ALWAYS	AUTO
Modality	(0008,0060)	MG	ALWAYS	AUTO
Series Description	(0008,103E)	Laterality + View + biopsy identifier (if applicable) + 'Breast Tomosynthesis Image' or 'C-View'	ALWAYS	AUTO
Operators' Name	(0008,1070)		ALWAYS	AUTO
Referenced Performed Procedure Step Sequence	(0008,1111)	One Item if MPPS enabled	ANAP	AUTO
Body Part Examined	(0018,0015)	BREAST	ALWAYS	AUTO
Protocol Name	(0018,1030)	Laterality and view	ALWAYS	AUTO
Series Instance UID	(0020,000E)	Unique value generated by AWS	ALWAYS	AUTO

Attribute Name	Tag	Value	Presence of Value	Source
Series Number	(0020,0011)	Note: The components of this value are as follows: wxx00000 w = Hologic identifier [7] xx = image type Breast Tomosynthesis = 32 C-View 2D = 33	ALWAYS	AUTO
Performed Procedure Step Start Date	(0040,0244)	Date first image acquired	ALWAYS	AUTO
Performed Procedure Step Start Time	(0040,0245)	Time first image acquired	ALWAYS	AUTO
Performed Procedure Step ID	(0040,0253)		ALWAYS	AUTO
Performed Procedure Step Description	(0040,0254)		ALWAYS	AUTO
Performed Protocol Code Sequence	(0040,0260)		ANAP	AUTO
Request Attributes Sequence	(0040,0275)	Present only for image objects resulting from scheduled procedure steps	ANAP	AUTO
>Item Attributes		See Table 7.1-5		

Table 7.3-3

IMAGE & PIXEL MODULES OF CREATED BREAST TOMOSYNTHESIS IMAGE INSTANCES

Attribute Name	Tag	Value	Presence of Value	Source
Image Type	(0008,0008)	DERIVED\PRIMARY\value 3\NONE Where value 3 is one of: VOLUME (non-biopsy), TOMO_SCOUT, POSTBIOPSY, POSTMARKER	ALWAYS	AUTO
Pixel Presentation	(0008,9205)	MONOCHROME	ALWAYS	AUTO
Volumetric Properties	(0008,9206)	VOLUME	ALWAYS	AUTO
Volume Based Calculation Technique	(0008,9207)	MAX_IP	ALWAYS	AUTO
Bits Allocated	(0028,0100)	16	ALWAYS	AUTO
Bits Stored	(0028,0101)	10	ALWAYS	AUTO
High Bit	(0028,0102)	9	ALWAYS	AUTO
Samples per Pixel	(0028,0002)	1	ALWAYS	AUTO
Photometric Interpretation	(0028,0004)	MONOCHROME2	ALWAYS	AUTO
Content Qualification	(0018,9004)	PRODUCT	ALWAYS	AUTO
Burned in Annotation	(0028,0301)	NO	ALWAYS	AUTO
Lossy Image Compression	(0028,2110)	00	ALWAYS	AUTO
Image Comments	(0020,4000)	User enters manually or selects from list	ANAP	USER
Quality Control Image	(0028,0300)	YES or NO	ANAP	AUTO
Presentation LUT Shape	(2050,0020)	IDENTITY	ALWAYS	AUTO

Attribute Name	Tag	Value	Presence of Value	Source
Rows	(0028,0010)		ALWAYS	AUTO
Columns	(0028,0011)		ALWAYS	AUTO
Pixel Representation	(0028,0103)	0	ALWAYS	AUTO
Pixel Padding Range Limit	(0028,0121)	4	ALWAYS	AUTO
Pixel Data	(7FE0,0010)		ALWAYS	AUTO

Table 7.3-4

MULTI-FRAME FUNCTIONAL GROUPS MODULE OF CREATED BREAST TOMOSYNTHESIS IMAGE INSTANCES

Attribute Name	Tag	Value	Presence of Value	Source
Instance Number	(0020,0013)		ALWAYS	AUTO
Content Date	(0008,0023)		ALWAYS	AUTO
Content Time	(0008,0033)		ALWAYS	AUTO
Number of Frames	(0028,0008)	Note: C-View 2D = 1	ALWAYS	AUTO
Shared Functional Groups Sequence	(5200,9229)	See Table 7.3-8 for content	ALWAYS	AUTO
Per-frame Functional Groups Sequence	(5200,9230)	See Table 7.3-8 for content Note: One Item for C-View 2D	ALWAYS	AUTO

Table 7.3-5

BREAST TOMOSYNTHESIS CONTRIBUTING SOURCES MODULE OF CREATED IMAGE INSTANCES

Attribute Name	Tag	Value	Presence of Value	Source
Contributing Sources Sequence	(0018,9506)	One Item	ALWAYS	AUTO
>Manufacturer	(0008,0070)	HOLOGIC, Inc.	ALWAYS	CONFIG
>Manufacturer's Model Name	(0008,1090)	Selenia Dimensions	ALWAYS	CONFIG
>Device Serial Number	(0018,1000)		ALWAYS	AUTO
>Software Versions	(0018,1020)		ALWAYS	AUTO
>Acquisition DateTime	(0008,002A)		ALWAYS	AUTO
>Station Name	(0008,1010)		ALWAYS	CONFIG
>Operators' Name	(0008,1070)		ALWAYS	AUTO
>Protocol Name	(0018,1030)	Laterality and view	ALWAYS	AUTO
>Rows	(0028,0010)	2048	ALWAYS	AUTO
>Columns	(0028,0011)	1280 or 1664	ALWAYS	AUTO
>Bits Stored	(0028,0101)	14	ALWAYS	AUTO
>Lossy Image Compression	(0028,2110)	00	ALWAYS	AUTO
>Detector Type	(0018,7004)	DIRECT	ALWAYS	AUTO
>Detector ID	(0018,700A)		ALWAYS	AUTO
>Date of Last Detector Calibration	(0018,700C)		ALWAYS	AUTO
>Time of Last Detector Calibration	(0018,700E)		ALWAYS	AUTO
>Detector Element Spacing	(0018,7022)	0.070\0.070	ALWAYS	AUTO

Table 7.3-6

BREAST TOMOSYNTHESIS ACQUISITION MODULE OF CREATED BREAST TOMOSYNTHESIS IMAGE INSTANCES

Attribute Name	Tag	Value	Presence of Value	Source
X-Ray 3D Acquisition Sequence	(0018,9507)	One Item	ALWAYS	AUTO
>Field of View Shape	(0018,1147)	RECTANGLE	ALWAYS	AUTO
>X-Ray Receptor Type	(0018,9420)	DIGITAL_DETECTOR	ALWAYS	AUTO
>Field of View Dimension(s) in Float	(0018,9461)		ALWAYS	AUTO
>Field of View Origin	(0018,7030)		ALWAYS	AUTO
>Field of View Rotation	(0018,7032)		ALWAYS	AUTO
>Field of View Horizontal Flip	(0018,7034)		ALWAYS	AUTO
>Grid	(0018,1166)		ALWAYS	AUTO
>KVP	(0018,0060)	Average	ALWAYS	AUTO
>X-Ray Tube Current in mA	(0018,9330)	Average	ALWAYS	AUTO
>Exposure Time in ms	(0018,9328)	Total	ALWAYS	AUTO
>Exposure in mAs	(0018,9332)	Total	ALWAYS	AUTO
>Start Acquisition DateTime	(0018,9516)		ALWAYS	AUTO
>Primary Positioner Scan Arc	(0018,9508)	Default = 15	ALWAYS	AUTO
>Primary Positioner Scan Start Angle	(0018,9510)	Default = (0018,1510) of center projection -7.5	ALWAYS	AUTO
>Primary Positioner Increment	(0018,9514)	Default = 1.071	ALWAYS	AUTO
>Distance Source to Detector	(0018,1110)		ALWAYS	AUTO
>Distance Source to Patient	(0018,1111)		ALWAYS	AUTO
>Estimated Radiographic Magnification Factor	(0018,1114)		ALWAYS	AUTO
>Anode Target Material	(0018,1191)		ALWAYS	AUTO
>Body Part Thickness	(0018,11A0)		ALWAYS	AUTO
>Compression Force	(0018,11A2)		ALWAYS	AUTO
>Paddle Description	(0018,11A4)		ALWAYS	AUTO
>Exposure Control Mode	(0018,7060)		ALWAYS	AUTO
>Exposure Control Mode Description	(0018,7062)		ALWAYS	AUTO
>Half Value Layer	(0040,0314)		ALWAYS	AUTO
>Focal Spot	(0018,1190)		ALWAYS	AUTO
>Detector Binning	(0018,701A)		ALWAYS	AUTO
>Detector Temperature	(0018,7001)		ALWAYS	AUTO
>Filter Type	(0018,1160)	STRIP	ALWAYS	AUTO
>Filter Material	(0018,7050)		ALWAYS	AUTO
>Filter Thickness Minimum	(0018,7052)		ALWAYS	AUTO
>Filter Thickness Maximum	(0018,7054)		ALWAYS	AUTO
>Organ Dose	(0040,0316)	Total Note: Not included in C-View 2D	ALWAYS	AUTO
>Entrance Dose in mGy	(0040,8302)	Total Note: Not included in C-View 2D	ALWAYS	AUTO
>Per Projection Acquisition Sequence	(0018,9538)	Fifteen Items	ALWAYS	AUTO
>>KVP	(0018,0060)	Average	ALWAYS	AUTO
>>X-Ray Tube Current in mA	(0018,9330)	Average	ALWAYS	AUTO
>>Frame Acquisition Duration	(0018,9220)	Individual	ALWAYS	AUTO
>>Collimator Shape	(0018,1700)	RECTANGULAR	ALWAYS	AUTO
>>Collimator Left Vertical Edge	(0018,1702)	0	ALWAYS	AUTO
>>Collimator Right Vertical Edge	(0018,1704)		ALWAYS	AUTO
>>Collimator Upper Horizontal Edge	(0018,1706)	0	ALWAYS	AUTO
>>Collimator Lower Horizontal Edge	(0018,1708)		ALWAYS	AUTO

Attribute Name	Tag	Value	Presence of Value	Source
>>Positioner Primary Angle	(0018,1510)	Individual values calculated given (0018,1510) of center projection	ALWAYS	AUTO
>>Exposure Time in ms	(0018,9328)	Individual	ALWAYS	AUTO
>>Exposure in mAs	(0018,9332)	Individual	ALWAYS	AUTO
>>Relative X-Ray Exposure	(0018,1405)	Average	ALWAYS	AUTO
>>Organ Dose	(0040,0316)	Individual Note: Not included in C-View 2D	ALWAYS	AUTO
>>Entrance Dose in mGy	(0040,8302)	Individual Note: Not included in C-View 2D	ALWAYS	AUTO

Table 7.3-7

BREAST VIEW MODULE OF CREATED BREAST TOMOSYNTHESIS IMAGE INSTANCES

Attribute Name	Tag	Value	Presence of Value	Source
View Code Sequence	(0054,0220)	One Item from CID 4014	ALWAYS	AUTO, USER
>View Modifier Code Sequence	(0054,0222)	Zero or more Items from CID 4015	VNAP	AUTO, USER
Breast Implant Present	(0028,1300)	YES or NO	ALWAYS	AUTO, USER
Partial View	(0028,1350)	YES or NO	ANAP	AUTO

7.1.1.8 Breast Tomosynthesis Image Macros

Table 7.3-8

MULTI-FRAME FUNCTIONAL GROUPS OF CREATED BREAST TOMOSYNTHESIS IMAGE INSTANCES

IE	Macro	Reference	Presence of Macro
Image	Pixel Measures	Table 7.3-9	ALWAYS / Per-frame
	Frame Content	Table 7.3-10	ANAP / Per-frame
	Plane Position (Patient)	Table 7.3-11	ALWAYS / Per-frame
	Plane Orientation (Patient)	Table 7.3-12	ALWAYS / Shared
	Derivation Image	Table 7.3-13	ALWAYS / Shared
	Frame Anatomy	Table 7.3-14	ALWAYS / Shared
	Identity Pixel Value Transformation	Table 7.3-15	ALWAYS / Shared
	Frame VOI LUT With LUT	Table 7.3-16	ALWAYS / Shared
	X-Ray 3D Frame Type	Table 7.3-17	ALWAYS / Per-frame

Table 7.3-9

PIXEL MEASURES MACRO OF CREATED BREAST TOMOSYNTHESIS IMAGE INSTANCES

Attribute Name	Tag	Value	Presence of Value	Source
>Pixel Measures Sequence	(0028,9110)	One Item	ALWAYS	AUTO
>>Pixel Spacing	(0028,0030)	Value may not vary per frame Note: C-View 2D contains the same values as the associated reconstructed slices.	ALWAYS	AUTO
>>Slice Thickness	(0018,0050)	Value may not vary per frame Note: C-View 2D contains Body Part Thickness (0018,11A0) from the source projections	ALWAYS	AUTO

Table 7.3-10

FRAME CONTENT MACRO OF CREATED BREAST TOMOSYNTHESIS IMAGE INSTANCES

Attribute Name	Tag	Value	Presence of Value	Source
>Frame Content Sequence	(0020,9111)	None of the conditionally required attributes applies; omitted.	ANAP	AUTO

Table 7.3-11

PLANE POSITION (PATIENT) MACRO OF CREATED BREAST TOMOSYNTHESIS IMAGE INSTANCES

Attribute Name	Tag	Value	Presence of Value	Source
>Plane Position Sequence	(0020,9113)	One Item	ALWAYS	AUTO
>>Image Position (Patient)	(0020,0032)		ALWAYS	AUTO

Table 7.3-12

PLANE ORIENTATION (PATIENT) MACRO OF CREATED BREAST TOMOSYNTHESIS IMAGE INSTANCES

Attribute Name	Tag	Value	Presence of Value	Source
>Plane Orientation Sequence	(0020,9116)	One Item	ALWAYS	AUTO
>>Image Orientation (Patient)	(0020,0037)	Pixel data orientation can be configured to match the user selected hanging protocol (dorsal or ventral).	ALWAYS	AUTO

Table 7.3-13

DERIVATION IMAGE MACRO OF CREATED BREAST TOMOSYNTHESIS IMAGE INSTANCES

Attribute Name	Tag	Value	Presence of Value	Source
>Derivation Image Sequence	(0008,9124)	One Item	ALWAYS	AUTO
>>Derivation Code Sequence	(0008,9215)	One Item containing (113072, DCM, "Multi-planar reformatting")	ALWAYS	AUTO
>>>Source Image Sequence	(0008,2112)	Reconstructed slices: One Item C-View 2D: Two Items	ALWAYS	AUTO
>>>>Referenced SOP Class UID	(0008,1150)	Secondary Capture Image Storage	ALWAYS	AUTO
>>>>Referenced SOP Instance UID	(0008,1155)	Reconstructed slices: Corresponding Raw Projection C-View 2D: Corresponding Raw C-View and Raw Projection	ALWAYS	AUTO
>>>>Spatial Locations Preserved	(0028,135A)	Reconstructed slices: NO C-View 2D: YES for Item 1, NO for Item 2	ALWAYS	AUTO
>>>>Purpose of Reference Code Sequence	(0040,A170)	One Item containing (121322, DCM, "Source image for image processing operation")	ALWAYS	AUTO

Table 7.3-14

FRAME ANATOMY MACRO OF CREATED BREAST TOMOSYNTHESIS IMAGE INSTANCES

Attribute Name	Tag	Value	Presence of Value	Source
>Frame Anatomy Sequence	(0020,9071)	One Item	ALWAYS	AUTO
>>Frame Laterality	(0020,9072)	L or R	ALWAYS	AUTO, USER
>>>Anatomic Region Sequence	(0008,2218)	One Item containing (T-04000, SRT, "Breast")	ALWAYS	AUTO

Table 7.3-15

IDENTITY PIXEL VALUE TRANSFORMATION MACRO OF CREATED BREAST TOMOSYNTHESIS IMAGE INSTANCES

Attribute Name	Tag	Value	Presence of Value	Source
>Pixel Value Transformation Sequence	(0028,9145)	One Item	ALWAYS	AUTO
>>Rescale Intercept	(0028,1052)	0	ALWAYS	AUTO
>>Rescale Slope	(0028,1053)	1	ALWAYS	AUTO
>>Rescale Type	(0028,1054)	US	ALWAYS	AUTO

Table 7.3-16

FRAME VOI LUT WITH LUT MACRO OF CREATED BREAST TOMOSYNTHESIS IMAGE INSTANCES

Attribute Name	Tag	Value	Presence of Value	Source
>Frame VOI LUT Sequence	(0028,9132)	One Item	ALWAYS	AUTO
>>Window Center	(0028,1050)		ALWAYS	AUTO
>>Window Width	(0028,1051)		ALWAYS	AUTO

Table 7.3-17

X-RAY 3D FRAME TYPE MACRO OF CREATED BREAST TOMOSYNTHESIS IMAGE INSTANCES

Attribute Name	Tag	Value	Presence of Value	Source
>X-Ray 3D Frame Type Sequence	(0018,9504)	One Item	ALWAYS	AUTO
>>Frame Type	(0008,9007)	See Image Type (0008,0008) in Table 7.3-3	ALWAYS	AUTO
>>Pixel Presentation	(0008,9205)	MONOCHROME	ALWAYS	AUTO
>>Volumetric Properties	(0008,9206)	VOLUME	ALWAYS	AUTO
>>Volume Based Calculation Technique	(0008,9207)	MAX_IP	ALWAYS	AUTO

7.1.1.9 Grayscale Softcopy Presentation State IOD

The attributes that are contained in created GSPS Instances are listed in the following tables.

Table 7.4-1

IOD OF CREATED GRAYSCALE SOFTCOPY PRESENTATION STATE INSTANCES

IE	Module	Reference	Presence of Module
Patient	Patient	Table 7.4-2	ALWAYS
Study	General Study	Table 7.4-3	ALWAYS
	Patient Study	Table 7.4-4	ALWAYS
Series	General Series	Table 7.4-5	ALWAYS
	Presentation Series	Table 7.4-5	ALWAYS
Equipment	General Equipment	Table 7.4-6	ALWAYS
Presentation State	Presentation State	Table 7.4-7	ALWAYS
	Displayed Area	Table 7.4-8	ALWAYS
	Graphic Annotation	Table 7.4-9	ALWAYS
	Graphic Layer	Table 7.4-10	ALWAYS
	Softcopy VOI LUT	Table 7.4-11	ALWAYS
	Softcopy Presentation LUT	Table 7.4-12	ALWAYS
	SOP Common	Table 7.4-13	ALWAYS

7.1.1.10 Grayscale Softcopy Presentation State Modules

Table 7.4-2

PATIENT MODULE OF CREATED GSPS INSTANCES

Attribute Name	Tag	Value	Presence of Value	Source
Patient's Name	(0010,0010)	Copied from current patient	ALWAYS	AUTO
Patient ID	(0010,0020)	Copied from current patient	ALWAYS	AUTO
Patient's Birth Date	(0010,0030)	Copied from current patient	VNAP	AUTO
Patient's Sex	(0010,0040)	Copied from current patient	VNAP	AUTO
All other Patient Attributes		Copied from current patient	ANAP	AUTO

Table 7.4-3

GENERAL STUDY MODULE OF CREATED GSPS INSTANCES

Attribute Name	Tag	Value	Presence of Value	Source
Study Date	(0008,0020)	Copied from current study	ALWAYS	AUTO
Study Time	(0008,0030)	Copied from current study	ALWAYS	AUTO
Accession Number	(0008,0050)	Copied from current study	VNAP	AUTO
Referring Physician's Name	(0008,0090)	Copied from current study	VNAP	AUTO
Study Description	(0008,1030)	Copied from current study	ANAP	AUTO
Study Instance UID	(0020,000D)	Copied from current study	ALWAYS	AUTO
Study ID	(0020,0010)	Copied from current study	VNAP	AUTO
All other Study Attributes		Copied from current study	ANAP	AUTO

Table 7.4-4

PATIENT STUDY MODULE OF CREATED GSPS INSTANCES

Attribute Name	Tag	Value	Presence of Value	Source
Patient's Age	(0010,1010)	Copied from current study	ANAP	AUTO
All other Patient Study Attributes		Copied from current study	ANAP	AUTO

Table 7.4-5

GENERAL AND PRESENTATION SERIES MODULE OF CREATED GSPS INSTANCES

Attribute Name	Tag	Value	Presence of Value	Source
Modality	(0008,0060)	PR	ALWAYS	AUTO
Series Instance UID	(0020,000E)	Unique	ALWAYS	AUTO
Series Number	(0020,0011)	1	ALWAYS	AUTO
Series Description	(0008,103E)		ALWAYS	AUTO
Operators' Name	(0008,1070)		ALWAYS	AUTO

Table 7.4-6

GENERAL EQUIPMENT MODULE OF CREATED GSPS INSTANCES

Attribute Name	Tag	Value	Presence of Value	Source
Manufacturer	(0008,0070)	HOLOGIC, Inc.	ALWAYS	AUTO
Institution Name	(0008,0080)		VNAP	CONFIG
Institution Address	(0008,0081)		VNAP	CONFIG
Station Name	(0008,1010)		ALWAYS	CONFIG
Manufacturer's Model Name	(0008,1090)	Selenia Dimensions	ALWAYS	AUTO
Software Versions	(0018,1020)	The current software version	ALWAYS	AUTO

Table 7.4-7

PRESENTATION STATE MODULE OF CREATED GSPS INSTANCES

Attribute Name	Tag	Value	Presence of Value	Source
Referenced Series Sequence	(0008,1115)	All images in current study	ALWAYS	AUTO
>Series Instance UID	(0020,000E)		ALWAYS	AUTO
>Referenced Image Sequence	(0008,1140)	One Item	ALWAYS	AUTO
>>Referenced SOP Class UID	(0008,1150)		ALWAYS	AUTO
>>Referenced SOP Instance UID	(0008,1155)		ALWAYS	AUTO
Instance Number	(0020,0013)	1	ALWAYS	AUTO
Content Label	(0070,0080)	HOLOGIC NOTE	ALWAYS	AUTO
Content Description	(0070,0081)	User name, Date, Time	ALWAYS	AUTO
Presentation Creation Date	(0070,0082)		ALWAYS	AUTO
Presentation Creation Time	(0070,0083)		ALWAYS	AUTO
Content Creator's Name	(0070,0084)	Current User's Name	ALWAYS	AUTO

Table 7.4-8

DISPLAYED AREA MODULE OF CREATED GSPS INSTANCES

Attribute Name	Tag	Value	Presence of Value	Source
Displayed Area Selection	(0070,005A)	One Item per image in Referenced Series Sequence	ALWAYS	AUTO
>Referenced Image Sequence	(0008,1140)	One Item	ALWAYS	AUTO
>>Referenced SOP Class UID	(0008,1150)		ALWAYS	AUTO
>>Referenced SOP Instance UID	(0008,1155)		ALWAYS	AUTO
>Displayed Area Top Left Hand Corner	(0070,0052)	0\0	ALWAYS	AUTO
>Displayed Area Bottom Right Hand Corner	(0070,0053)	Columns\Rows	ALWAYS	AUTO
>Presentation Size Mode	(0070,0100)	SCALE TO FIT	ALWAYS	AUTO
>Presentation Pixel Aspect Ratio	(0070,0102)	1\1	ALWAYS	AUTO

Table 7.4-9

GRAPHIC ANNOTATION MODULE OF CREATED GSPS INSTANCES

Attribute Name	Tag	Value	Presence of Value	Source
Graphic Annotation Sequence	(0070,0001)	Zero or more items	ALWAYS	USER
>Referenced Image Sequence	(0008,1140)	One Item	ALWAYS	AUTO
>>Referenced SOP Class UID	(0008,1150)		ALWAYS	AUTO
>>Referenced SOP Instance UID	(0008,1155)		ALWAYS	AUTO
>>Referenced Frame Number	(0008,1160)		ANAP	AUTO
>Graphic Layer	(0070,0002)	LAYER0	ALWAYS	AUTO
>Text Object Sequence	(0070,0008)	Zero or more items	ALWAYS	USER
>>Anchor Point Annotation Units	(0070,0004)	PIXEL	ALWAYS	AUTO
>>Unformatted Text Value	(0070,0006)		ALWAYS	USER
>>Anchor Point	(0070,0014)		ALWAYS	AUTO
>>Anchor Point Visibility	(0070,0015)	N	ALWAYS	AUTO
>Graphic Object Sequence	(0070,0009)	Zero or more items	ALWAYS	USER
>>Graphic Annotation Units	(0070,0005)	PIXEL	ALWAYS	AUTO
>>Graphic Dimensions	(0070,0020)	2	ALWAYS	AUTO
>>Number of Graphic Points	(0070,0021)	Depends on Graphic Type	ALWAYS	AUTO
>>Graphic Data	(0070,0022)	Depends on Graphic Type	ALWAYS	USER
>>Graphic Type	(0070,0023)	ELLIPSE or POLYLINE	ALWAYS	USER
>>Graphic Filled	(0070,0024)	N	ALWAYS	AUTO

Table 7.4-10

GRAPHIC LAYER MODULE OF CREATED GSPS INSTANCES

Attribute Name	Tag	Value	Presence of Value	Source
Graphic Layer Sequence	(0070,0060)	One item if Graphic Annotation Sequence is present	ALWAYS	AUTO
>Graphic Layer	(0070,0002)	LAYER0	ALWAYS	AUTO
>Graphic Layer Order	(0070,0062)	1	ALWAYS	AUTO
>Graphic Layer Recommended Display Grayscale Value	(0070,0066)	FFFFH	ALWAYS	AUTO

Table 7.4-11

SOFTCOPY VOI LUT MODULE OF CREATED GSPS INSTANCES

Attribute Name	Tag	Value	Presence of Value	Source
Softcopy VOI LUT Sequence	(0028,3110)	One item per image in Referenced Series Sequence. Item will contain either one VOI LUT Sequence Item or one pair of WC/WW values	ANAP	AUTO
>Referenced Image Sequence	(0008,1140)	One Item	ALWAYS	AUTO
>>Referenced SOP Class UID	(0008,1150)		ALWAYS	AUTO
>>Referenced SOP Instance UID	(0008,1155)		ALWAYS	AUTO
>Window Center	(0028,1050)	Single Value if present	ANAP	USER
>Window Width	(0028,1051)	Single Value if present	ANAP	USER
>VOI LUT Function	(0028,1056)	LINEAR	ANAP	USER
>VOI LUT Sequence	(0028,3010)	One item if present	ANAP	USER
>>LUT Descriptor	(0028,3002)		ANAP	USER
>>LUT Data	(0028,3006)		ANAP	USER

Table 7.4-12

SOFTCOPY PRESENTATION LUT MODULE OF CREATED GSPS INSTANCES

Attribute Name	Tag	Value	Presence of Value	Source
Presentation LUT Shape	(2050,0020)	IDENTITY	ALWAYS	AUTO

Table 7.4-13

SOP COMMON MODULE OF CREATED GSPS INSTANCES

Attribute Name	Tag	Value	Presence of Value	Source
Specific Character Set	(0008,0005)	ISO_IR 100	ALWAYS	AUTO
Instance Creation Date	(0008,0012)	Current Date	ALWAYS	AUTO
Instance Creation Time	(0008,0013)	Current Time	ALWAYS	AUTO
SOP Class UID	(0008,0016)	UID for Grayscale Softcopy Presentation State Storage	ALWAYS	AUTO
SOP Instance UID	(0008,0018)	Unique	ALWAYS	AUTO

7.1.1.11 CT Image IOD

The default attributes that are contained in created SOP Instances are listed in the following tables. The attributes contained in created SOP Instances are configurable.

Table 7.5-1

IOD OF CREATED CT IMAGE SOP INSTANCES

IE	Module	Reference	Presence of Module
Patient	Patient	Table 7.1-2	ALWAYS
Study	General Study	Table 7.1-3	ALWAYS
	Patient Study	Table 7.1-4	ALWAYS
Series	General Series	Table 7.5-2	ALWAYS
Frame of Reference	Frame of Reference	Table 7.1-7	ALWAYS (UID: ALWAYS)
Equipment	General Equipment	Table 7.1-6	ALWAYS
Image	General Image	Table 7.5-3	ALWAYS
	Image Plane	Table 7.5-5	ALWAYS
	Image Pixel	Table 7.5-6	ALWAYS
	CT Image	Table 7.5-4	ALWAYS
	VOI LUT	Table 7.5-7	ALWAYS
	SOP Common	Table 7.1-8	ALWAYS

7.1.1.12 CT Image Modules

Table 7.5-2

GENERAL SERIES MODULE OF CREATED SOP INSTANCES

Attribute Name	Tag	Value	Presence of Value	Source
Modality	(0008,0060)	CT (default) or MG	ALWAYS	CONFIG
Series Instance UID	(0020,000E)	Unique value generated by AWS Note: All CT Image Instances that represent a single laterality+view reconstructed slices data set have the same Series Instance UID value.	ALWAYS	AUTO
Series Number	(0020,0011)	Note: The components of this value are as follows: wxx00000 w = Hologic identifier [7] xx (image type) = 34	ALWAYS	AUTO
Laterality	(0020,0060)	See Table 7.2-2		
Series Date	(0008,0021)	See Table 7.2-2		
Series Time	(0008,0031)	See Table 7.2-2		
Protocol Name	(0018,1030)	See Table 7.2-2		
Series Description	(0008,103E)	laterality + view + biopsy identifier (if applicable) + 'Tomosynthesis Reconstruction CT Image'	ALWAYS	AUTO
Operators' Name	(0008,1070)	See Table 7.2-2		
Referenced Performed Procedure Step Sequence	(0008,1111)	See Table 7.2-2		
Body Part Examined	(0018,0015)	See Table 7.2-2		
Patient Position	(0018,5100)		EMPTY	AUTO
Request Attributes Sequence	(0040,0275)	See Table 7.2-2		
Performed Procedure Step ID	(0040,0253)	See Table 7.2-2		
Performed Procedure Start Date	(0040,0244)	See Table 7.2-2		
Performed Procedure Start Time	(0040,0245)	See Table 7.2-2		
Performed Procedure Step Description	(0040,0254)	See Table 7.2-2		
Performed Protocol Code Sequence	(0040,0260)	See Table 7.2-2		

Table 7.5-3

GENERAL IMAGE MODULE OF CREATED SOP INSTANCES

Attribute Name	Tag	Value	Presence of Value	Source
Instance Number	(0020,0013)	A sequential integer value for each reconstructed slice in a data set (Series), starting with 1.	ALWAYS	AUTO
Patient Orientation	(0020,0020)	Reconstructed slices pixel data orientation can be configured to match the user selected hanging protocol (dorsal or ventral).	ALWAYS	AUTO, USER
Content Date	(0008,0023)	Same as Acquisition Date (0008,0022)	ALWAYS	AUTO
Content Time	(0008,0033)	Same as Acquisition Time (0008,0032)	ALWAYS	AUTO
Acquisition Date	(0008,0022)		ALWAYS	AUTO
Acquisition Time	(0008,0032)		ALWAYS	AUTO
Source Image Sequence	(0008,2112)	One Item to reference the source tomosynthesis raw projection	ALWAYS	AUTO
>Referenced SOP Class UID	(0008,1150)	1.2.840.10008.5.1.4.1.1.7	ALWAYS	AUTO
>Referenced SOP Instance UID	(0008,1155)		ALWAYS	AUTO
>Purpose of Reference Code Sequence	(0040,A170)	One Item containing (121322, DCM, "Source image for image processing operation")	ALWAYS	AUTO
>Spatial Locations Preserved	(0028,135A)	NO	ALWAYS	AUTO
Irradiation Event UID	(0008,3010)		ALWAYS	AUTO
Images in Acquisition	(0020,1002)	Number of reconstructed slices in the data set	ALWAYS	AUTO
Image Comments	(0020,4000)	User enters manually or selects from list	ANAP	USER
Quality Control Image	(0028,0300)	YES or NO	ALWAYS	AUTO
Burned in Annotation	(0028,0301)	NO	ALWAYS	AUTO
Lossy Image Compression	(0028,2110)	00	ALWAYS	AUTO
Presentation LUT Shape	(2050,0020)	IDENTITY	ALWAYS	AUTO

Table 7.5-4

CT IMAGE MODULE OF CREATED SOP INSTANCES

Attribute Name	Tag	Value	Presence of Value	Source
Image Type	(0008,0008)	DERIVED\PRIMARY\value 3 Where value 3 is one of: TOMO (non-biopsy), TOMO_SCOUT, POSTBIOPSY	ALWAYS	AUTO
Samples Per Pixel	(0028,0002)	1	ALWAYS	AUTO
Photometric Interpretation	(0028,0004)	MONOCHROME2	ALWAYS	AUTO
Bits Allocated	(0028,0100)	16	ALWAYS	AUTO
Bits Stored	(0028,0101)	12	ALWAYS	AUTO
High Bit	(0028,0102)	11	ALWAYS	AUTO
Rescale Intercept	(0028,1052)	0	ALWAYS	AUTO
Rescale Slope	(0028,1053)	1	ALWAYS	AUTO
Rescale Type	(0028,1054)	US	ALWAYS	AUTO
KVP	(0018,0060)	Mean value for all source projections	ALWAYS	AUTO
Acquisition Number	(0020,0012)	Same as Instance Number (0020,0013)	ALWAYS	AUTO
Distance Source to Detector	(0018,1110)	From source projections	ALWAYS	AUTO
Distance Source to Patient	(0018,1111)	From source projections	ALWAYS	AUTO
Exposure Time	(0018,1150)	Total (cumulative) for all source projections	ALWAYS	AUTO
X-Ray Tube Current	(0018,1151)	Mean for all source projections	ALWAYS	AUTO
Exposure	(0018,1152)	Total (cumulative) for all source projections	ALWAYS	AUTO
Exposure in uAs	(0018,1153)	Total (cumulative) for all source projections	ALWAYS	AUTO
Focal Spot(s)	(0018,1190)	From source projections	ALWAYS	AUTO
Anatomic Region Sequence	(0008,2218)	One Item containing (T-04000, SRT, "Breast")	ALWAYS	AUTO

Table 7.5-5

IMAGE PLANE MODULE OF CREATED SOP INSTANCES

Attribute Name	Tag	Value	Presence of Value	Source
Pixel Spacing	(028,0030)	Values that represent the center of the compressed body part apply to all instances for a reconstructed slices data set	ALWAYS	AUTO
Image Orientation (Patient)	(0020,0037)	Reconstructed slices pixel data orientation can be configured to match the user selected hanging protocol (dorsal or ventral). Note: The same values are used for all instances for a reconstructed slices data set.	ALWAYS	AUTO
Image Position (Patient)	(0020,0032)		ALWAYS	AUTO
Slice Thickness	(0018,0050)	1	ALWAYS	AUTO

Table 7.5-6

IMAGE PIXEL MODULE OF CREATED SOP INSTANCES

Attribute Name	Tag	Value	Presence of Value	Source
Rows	(0028,0010)	Value may vary	ALWAYS	AUTO
Columns	(0028,0011)	Value may vary	ALWAYS	AUTO
Pixel Representation	(0028,0103)	0000H	ALWAYS	AUTO
Pixel Padding Range Limit	(0028,0121)	16	ANAP	AUTO
Pixel Data	(7FE0,0010)		ALWAYS	AUTO

Table 7.5-7

VOI LUT MODULE OF CREATED SOP INSTANCES

Attribute Name	Tag	Value	Presence of Value	Source
Window Center	(0028,1050)	2048	ALWAYS	AUTO
Window Width	(0028,1051)	2048	ALWAYS	AUTO

7.1.1.13 X-Ray Radiation Dose SR IOD

The default attributes that are contained in created SOP Instances are listed in the following tables.

Table 7.6-1

IOD OF CREATED X-RAY RADIATION DOSE SR SOP INSTANCES

IE	Module	Reference	Presence of Module
Patient	Patient	Table 7.1-2	ALWAYS
Study	General Study	Table 7.1-3	ALWAYS
	Patient Study	Table 7.6-2	ALWAYS
Series	SR Document Series	Table 7.6-3	ALWAYS
Equipment	General Equipment	Table 7.1-6	ALWAYS
	Enhanced General Equipment	Table 7.1-6	ALWAYS
Document	SR Document General	Table 7.6-4	ALWAYS
	SR Document Content	Table 7.6-5	ALWAYS
	SOP Common	Table 7.1-8	ALWAYS

7.1.1.14 X-Ray Radiation Dose Modules

Table 7.6-2

PATIENT STUDY MODULE OF CREATED SOP INSTANCES

Attribute Name	Tag	Value	Presence of Value	Source
Admitting Diagnoses Description	(0008,1080)		ANAP	MWL
Admitting Diagnoses Code Sequence	(0008,1084)		ANAP	MWL
>Code Value	(0008,0100)			
>Code Scheme Designator	(0008,0102)			
>Code Meaning	(0008,0104)			
Patient's Age	(0010,1010)	Calculated from (0010,0030). Based on the age of the patient when the study was performed	ALWAYS	AUTO
Patient's Size	(0010,1020)		ANAP	MWL
Patient's Weight	(0010,1030)		ANAP	MWL

Table 7.6-3

SR DOCUMENT SERIES MODULE OF CREATED SOP INSTANCES

Attribute Name	Tag	Value	Presence of Value	Source
Modality	(0008,0060)	SR	ALWAYS	AUTO
Series Instance UID	(0020,000E)		ALWAYS	AUTO
Series Number	(0020,0011)	Value may vary	ALWAYS	AUTO
Series Date	(0008,0021)		ALWAYS	AUTO
Series Time	(0008,0031)		ALWAYS	AUTO
Series Description	(0008,103E)	Default = 'Radiation Dose Information'	ALWAYS	AUTO
Referenced Performed Procedure Step Sequence	(0008,1111)	One Item when MPPS is enabled to identify MPPS SOP Instance of referenced images. Otherwise zero length.	VNAP	AUTO
>Referenced SOP Class UID	(0008,1150)			
>Referenced SOP Instance UID	(0008,0055)			

Table 7.6-4

SR DOCUMENT GENERAL MODULE OF CREATED SOP INSTANCES

Attribute Name	Tag	Value	Presence of Value	Source
Content Date	(0008,0023)		ALWAYS	AUTO
Content Time	(0008,0033)		ALWAYS	AUTO
Instance Number	(0020,0013)		ALWAYS	AUTO
Referenced Request Sequence	(0040,A370)	One Item	ANAP	MWL
>Study Instance UID	(0020,000D)			
>Referenced Study Sequence	(0008,1110)			
>>Referenced SOP Class UID	(0008,1150)			
>>Referenced Sop Instance UID	(0008,1155)			
>Accession Number	(0008,0050)			
>Placer Order Number/Imaging Service Request	(0040,2016)		EMPTY	AUTO
>Filler Order Number/Imaging Service Request	(0040,2017)		EMPTY	AUTO
>Requested Procedure ID	(0040,1001)		VNAP	AUTO
>Requested Procedure Description	(0032,1060)		VNAP	AUTO
>Requested Procedure Code Sequence	(0032,1064)		VNAP	AUTO
>>Code Value	(0008,0100)			
>>Coding Scheme Designator	(0008,0102)			
>>Code Meaning	(0008,0104)			
>Reason for Requested Procedure Code Sequence	(0040,100A)		ANAP	AUTO
>>Code Value	(0008,0100)			
>>Coding Scheme Designator	(0008,0102)			
>>Code Meaning	(0008,0104)			
Performed Procedure Code Sequence			VNAP	AUTO
>Code Value	(0008,0100)			
>Coding Scheme Designator	(0008,0102)			
>Code Meaning	(0008,0104)			
Current Requested Procedure Evidence Sequence	(0040,A375)	One Item for each image instance that represents a recorded irradiation event	ALWAYS	AUTO
>Referenced Series Sequence	(0008,1115)	One Item		
>>Referenced SOP Sequence	(0008,1199)	One Item		
>>>Referenced SOP Class UID	(0008,1150)			
>>> Referenced SOP Instance UID	(0008,1155)			
>>Series Instance UID	(0020,000E)			
>Study Instance UID	(0020,000D)			
Completion Flag	(0040,A491)	COMPLETE	ALWAYS	AUTO
Verification Flag	(0040,A493)	UNVERIFIED	ALWAYS	AUTO

Table 7.6-5

SR DOCUMENT CONTENT MODULE OF CREATED SOP INSTANCES

Attribute Name	Tag	Value	Presence of Value	Source
Value Type	(0040,A040)	CONTAINER	ALWAYS	AUTO
Concept Name Code Sequence	(0040,A043)		ALWAYS	AUTO
>Code Value	(0008,0100)	Value = 113701		
>Coding Scheme Designator	(0008,0102)	Value = DCM		
>Code Meaning	(0008,0104)	Value = X-Ray Radiation Dose Report		
Continuity of Content	(0040,A050)	Value = SEPARATE	ALWAYS	AUTO
Content Template Sequence	(0040,A504)		ALWAYS	AUTO
>Mapping Resource	(0008,0105)	Value = DCMR		
>Template Identifier	(0040,DB00)	Value = 10001		
Content Sequence	(0040,A730)	One or more items based on TID (10001) Projection X-Ray Radiation Dose	ALWAYS	AUTO
>(Items 1..n)		See Table 7.6-6		

Table 7.6-6

PROJECTION X-RAY RADIATION DOSE (TID 10001)

NL	Rel with Parent	VT	Concept Name	Value
	HAS CONCEPT MOD	CODE	(121058, DCM, "Procedure Reported")	(P5-40010, SRT, "Mammography")
>	HAS CONCEPT MOD	CODE	(G-C0E8, SRT, "Has Intent")	(R-408C3, SRT, "Diagnostic Intent")
		INCLUDE	DTID (1002) Observer Context	See Table 7.6-7
	HAS OBS CONTEXT	CODE	(113705, DCM, "Scope of Accumulation")	(113014, DCM, "Study")
>	HAS PROPERTIES	UIDREF	(110180, DCM, "Study Instance UID")	Top level Study Instance UID value
	CONTAINS	CODE	(113945, DCM, "X-Ray Detector Data Available")	(R-0038D, SRT, "Yes")
	CONTAINS	CODE	(113943, DCM, "X-Ray Source Data Available")	(R-0038D, SRT, "Yes")
	CONTAINS	CODE	(113944, DCM, "X-Ray Mechanical Data Available")	(R-0038D, SRT, "Yes")
	CONTAINS	INCLUDE	DTID (10002) Accumulated X-Ray Dose	See Table 7.6-9
	CONTAINS	INCLUDE	DTID (10003) Irradiation Event X-Ray Data	Sequence item for each irradiation event in the study where: Each 2D acquisition = one event Each 3D acquisition = one event See Table 7.6-11
	CONTAINS	CODE	(113854, DCM, "Source of Dose Information")	(113867, DCM, "Computed From Image Attributes")

Table 7.6-7

OBSERVER CONTEXT (TID 1002)

NL	Rel with Parent	VT	Concept Name	Value
	HAS OBS CONTEXT	CODE	(121005, DCM, "Observer Type")	(121007, DCM, "Device")
	HAS OBS CONTEXT	INCLUDE	DTID (1004) Device Observer Identifying Attributes	See Table 7.6-8

Table 7.6-8

DEVICE OBSERVER IDENTIFYING ATTRIBUTES (TID 1004)

NL	Rel with Parent	VT	Concept Name	Value
		UIDREF	(121012, DCM, "Device Observer UID")	Instance Creator UID value

Table 7.6-9

ACCUMULATED X-RAY DOSE (TID 10002)

NL	Rel with Parent	VT	Concept Name	Value
		CONTAINER	(113702, DCM, "Accumulated X-Ray Dose Data")	
>	HAS CONCEPT MOD	CODE	(113764, DCM, "Acquisition Plane")	(113622, DCM, "Single Plane")
>	CONTAINS	INCLUDE	DTID (10005) Accumulated Mammography X-Ray Dose	See Table 7.6-10

Table 7.6-10

ACCUMULATED MAMMOGRAPHY X-RAY DOSE (TID 10005)

NL	Relationship Type	VT	Concept Name	Value
		NUM	(111637, DCM, "Accumulated Average Glandular Dose")	Two sequence items for bilateral Cumulative per breast Calculated from source images
>	HAS CONCEPT MOD	CODE	(G-C171, SRT, "Laterality")	(T-04030, SRT, "Left breast") or (T-04020, SRT, "Right breast")

Table 7.6-11

IRRADIATION EVENT X-RAY DATA (TID 10003)

NL	Rel with Parent	VT	Concept Name	Value
		CONTAINER	(113706, DCM, "Irradiation Event X-Ray Data")	
>	HAS CONCEPT MOD	CODE	(113764, DCM, "Acquisition Plane")	(113622, DCM, "Single Plane")
>	CONTAINS	UIDREF	(113769, DCM, "Irradiation Event UID")	Copied from source image
>	CONTAINS	DATETIME	(111526, DCM, "DateTime Started")	Copied from source image
>	CONTAINS	CODE	(113721, DCM, "Irradiation Event Type")	2D: (113611, DCM, "Stationary Acquisition") 3D: (113613, DCM, "Rotational Acquisition")
>	CONTAINS	CODE	(T-D0005, SRT, "Anatomical structure")	(T-04000, SRT, "Breast")
>>	HAS CONCEPT MOD	CODE	(G-C171, SRT, "Laterality")	(G-A100, SRT, "Right") or (G-A101, SRT, "Left")
>	CONTAINS	CODE	(111031, DCM, "Image View")	Copied from source image
>>	HAS CONCEPT MOD	CODE	(111032, DCM, "Image View Modifier")	Copied from source image if present
>	CONTAINS	CODE	(123014, DCM, "Target Region")	(T-04000, SRT, "Breast")
>	CONTAINS	NUM	(111634, DCM, "Half Value Layer")	Copied from source image
>	CONTAINS	NUM	(111636, DCM, "Entrance Exposure at RP")	Copied from source image
>	CONTAINS	CODE	(113780, DCM, "Reference Point Definition")	(113865, DCM, "Entrance exposure to a 4.2 cm breast thickness")
>	CONTAINS	INCLUDE	DTID (10003A) Irradiation Event X-Ray Detector Data	See Table 7.6-12
>	CONTAINS	INCLUDE	DTID (10003B) Irradiation Event X-Ray Source Data	See Table 7.6-13
>	CONTAINS	INCLUDE	DTID (10003C) Irradiation Event Mechanical Data	See Table 7.6-15

Table 7.6-12
IRRADIATION EVENT X-RAY DETECTOR DATA (TID 10003A)

NL	Rel with Parent	VT	Concept Name	Value
		IMAGE	(113795, DCM, "Acquired Image")	Reference to source image

Table 7.6-13
IRRADIATION EVENT X-RAY SOURCE DATA (TID 10003B)

NL	Rel with Parent	VT	Concept Name	Value
		NUM	(111631, DCM, "Average Glandular Dose")	Copied from source image
		NUM	(113733, DCM, "KVP")	Copied from source image
		NUM	(113734, DCM, "X-Ray Tube Current")	Copied from source image
		NUM	(113824, DCM, "Exposure Time")	Copied from source image
		NUM	(113736, DCM, "Exposure")	Copied from source image
		NUM	(113766, DCM, "Focal Spot Size")	Copied from source image
		CODE	(111632, DCM, "Anode Target Material")	Based on source image (C-164F9, SRT, "Tungsten or Tungsten compound")
		CONTAINER	(113771, DCM, "X-Ray Filters")	
>	CONTAINS	CODE	(113722, DCM, "X-Ray Filter Type")	Based on source image (111650, DCM, "Strip filter")
>	CONTAINS	CODE	(113757, DCM, "X-Ray Filter Material")	Based on source image (C-120F9, SRT, "Aluminum or Aluminum compound") or (C-167F9, SRT, "Rhodium or Rhodium compound") or (C-137F9, SRT, "Silver or Silver compound") or (C-127F9, SRT, "Copper or Copper compound")
>	CONTAINS	NUM	(113758, DCM, "X-Ray Filter Thickness Minimum")	Copied from source image
>	CONTAINS	NUM	(113773, DCM, "X-Ray Filter Thickness Maximum")	Copied from source image
		CODE	(111635, DCM, "X-Ray Grid")	Based on source image (111646, DCM, "No grid") or (gridin, 99HOLX, "Grid in")
		INCLUDE	DTID (1021) Device Participant	Present only if the device differs from the device recorded in the Enhanced General Equipment module (i.e. study started on one device, completed on a different device) See Table 7.6-14

*Table 7.6-14
DEVICE PARTICIPANT (TID 1021)*

NL	Rel with Parent	VT	Concept Name	Value
		CODE	(113876, DCM, "Device Role in Procedure")	(113859, DCM, "Irradiating Device")
>	HAS PROPERTIES	TEXT	(113878, DCM, "Device Manufacturer")	
>	HAS PROPERTIES	TEXT	(113879, DCM, "Device Model Name")	
>	HAS PROPERTIES	TEXT	(113880, DCM, "Device Serial Number")	
>	HAS PROPERTIES	TEXT	(121012, DCM, "Device Observer UID")	Instance Creator UID value

*Table 7.6-15
IRRADIATION EVENT MECHANICAL DATA (TID 10003C)*

NL	Rel with Parent	VT	Concept Name	Value
		CODE	(113956, DCM, "CR/DR Mechanical Configuration")	(113954, DCM, "Upright Stand Mount")
		NUM	(112011, DCM, "Positioner Primary Angle")	Copied or calculated from source image
		NUM	(113739, DCM, "Positioner Primary End Angle")	3D only: Calculated from source image
		NUM	(111633, DCM, "Compression Thickness")	Copied from source image
		NUM	(113750, DCM, "Distance Source to Detector")	Copied from source image

7.1.2 Usage of Attributes from Received IODs

The following attributes are required to be present with a non-zero length value for successful interpretation of received Digital Mammography X-Ray Image SOP Instances:

- (0008,0016) SOP Class UID: one of the supported values
- (0008,0068) Presentation Intent Type
- (0008,1030) Study Description
- (0010,0020) Patient ID
- (0020,0011) Series Number
- (0020,0013) Instance Number
- (0028,0010) Rows
- (0028,0011) Columns
- At least one of the following:
 - (0008,0050) Accession Number
 - (0020,0010) Study ID
 - (0040,1001) Requested Procedure ID
- At least one attribute that identifies the mammography view

7.1.3 Attribute Mapping

The default relationships between attributes received via Modality Worklist and stored in acquired images and MPPS Instances are summarized in Table 7.1.3-14. Attribute mapping is configurable.

Table 7.1.3-14

ATTRIBUTE MAPPING BETWEEN MODALITY WORKLIST, IMAGE, AND MPPS

Modality Worklist	Image IOD	MPPS
Patient's Name	Patient's Name	Patient's Name
Patient ID	Patient ID	Patient ID
Issuer of Patient ID	Issuer of Patient ID	
Patient's Birth Date	Patient's Birth Date	Patient's Birth Date
Patient's Sex	Patient's Sex	Patient's Sex
Other Patient IDs	Other Patient IDs	
Referring Physician's Name	Referring Physician's Name	
Study Description	Study Description	
Study ID	Study ID	Study ID
		Scheduled Step Attributes Sequence
Referenced Study Sequence	Referenced Study Sequence	>Referenced Study Sequence
>Referenced SOP Class UID	>Referenced SOP Class UID	>>Referenced SOP Class UID
>Referenced SOP Instance UID	>Referenced SOP Instance UID	>>Referenced SOP Instance UID
Study Instance UID	Study Instance UID	>Study Instance UID
Accession Number	Accession Number	>Accession Number
Scheduled Procedure Step Sequence	Request Attributes Sequence	
>Scheduled Procedure Step Description	>Scheduled Procedure Step Description	>Scheduled Procedure Step Description
>Scheduled Protocol Code Sequence	>Scheduled Protocol Code Sequence	>Scheduled Protocol Code Sequence
>>Code Value	>>Code Value	>>Code Value
>>Coding Scheme Designator	>>Coding Scheme Designator	>>Coding Scheme Designator
>>Code Meaning	>>Code Meaning	>>Code Meaning
>Scheduled Procedure Step ID	>Scheduled Procedure Step ID	>Scheduled Procedure Step ID
>Reason for Requested Procedure Code Sequence	>Reason for Requested Procedure Code Sequence	
>>Code Value	>>Code Value	
>>Coding Scheme Designator	>>Coding Scheme Designator	
>>Code Meaning	>>Code Meaning	
Requested Procedure ID	>Requested Procedure ID	>Requested Procedure ID
Requested Procedure Description	>Requested Procedure Description	>Requested Procedure Description
	Performed Protocol Code Sequence	Performed Protocol Code Sequence
	>Code Value	>Code Value
	>Coding Scheme Designator	>Coding Scheme Designator
	>Code Meaning	>Code Meaning
	Performed Procedure Step ID	Performed Procedure Step ID
	Performed Procedure Step Start Date	Performed Procedure Step Start Date
	Performed Procedure Step Start Time	Performed Procedure Step Start Time
	Performed Procedure Step Description	Performed Procedure Step Description
Scheduled Protocol Code Sequence	Procedure Code Sequence	Procedure Code Sequence
		Performed Series Sequence
	Protocol Name	>Protocol Name

The following additional rules apply for mapping Modality Worklist attributes to image and MPPS Instances:

(0040,0007) Scheduled Procedure Step Description, (0040,0008) Scheduled Protocol Code Sequence, (0040,0009) Scheduled Procedure Step ID, (0040,1001) Requested Procedure ID:

- For a scheduled procedure the Acquisition Workstation incorporates these attributes from the worklist into the Request Attributes Sequence (0040,0275) of the image object and the Scheduled Step Attributes Sequence (0040,0270) of the MPPS Instance.
- For unscheduled procedures there is no Request Attributes Sequence (0040,0275) in the image object, and these attributes are absent from the MPPS Instance.

(0020,000D) Study Instance UID:

- For a scheduled procedure the Acquisition Workstation copies this attribute from the worklist into the image object and the Scheduled Step Attributes Sequence (0040,0270) of the MPPS Instance.
- For unscheduled procedures the Acquisition Workstation creates the value.

(0008,1110) Referenced Study Sequence:

- For a scheduled procedure the Acquisition Workstation incorporates this attribute from the worklist into the image object and the Scheduled Step Attributes Sequence (0040,0270) of the MPPS Instance. The number of sequence items corresponds to the number of scheduled procedure steps grouped for a performed procedure step (normally one).
- For unscheduled procedures there is no Referenced Study Sequence in the image object or the MPPS Instance.

(0008,0050) Accession Number:

- For a scheduled procedure the Acquisition Workstation incorporates this attribute from the worklist into the image object and the Scheduled Step Attributes Sequence (0040,0270) of the MPPS Instance.

7.1.4 Coerced/Modified Attributes

The Acquisition Workstation can be configured to add, edit, or remove specific attributes in received SOP Instances. By default, the Acquisition Workstation will attempt to add missing attributes that are required for interpretation by the display module, such as the Private Attributes (0019) of Hologic Digital Mammography X-Ray Image objects.

The following characters in textual return key attribute values of a Modality Worklist item are modified automatically by the Acquisition Workstation when mapped to an image object:

- Ampersand Symbol (&): Mapped to “.AND.”
- Double Quote Symbol (“): Mapped to “” (single quote)
- Greater Than Symbol (>): Mapped to “.GT.”
- Less Than Symbol (<): Mapped to “.LT.”

7.2 Data Dictionary of Private Attributes

Created SOP Instances may contain a Private Group (0019) labeled HOLOGIC, Inc., containing proprietary image characteristics relating to compression paddle, collimation, and automatic exposure control for Digital Mammography X-Ray Image, Secondary Capture Image, CT Image and Breast Tomosynthesis Image objects.

Created Secondary Capture Image SOP Instances contain private pixel data in Private Group (7E01).

Created Digital Mammography X-Ray Image and Breast Tomosynthesis Image SOP Instances for C-View 2D may contain a Private Group (7E01).

No patient identification information is included in these private attributes.

7.3 Coded Terminology and Templates

7.4 Grayscale Image Consistency

High Resolution monitor display calibration is performed according to the DICOM Grayscale Standard Display Function. See DICOM PS 3.14 for additional Grayscale Standard Display Function information.

7.5 Standard Extended/Specialized/Private SOP Classes

7.5.1 Secondary Capture Image Storage SOP Class

By default the Secondary Capture Image Storage SOP Class is Standard Extended by the attributes defined in Table 7.5.1-1. The attributes contained in created SOP Instances are configurable.

Table 7.5.1-1

STANDARD EXTENDED ATTRIBUTES OF CREATED SECONDARY CAPTURE IMAGE SOP INSTANCES

Attribute Name	Tag	Value	Presence of Value	Source
KVP	(0018,0060)	From x-ray system	ALWAYS	AUTO
Distance Source to Detector	(0018,1110)		ALWAYS	AUTO
Distance Source to Patient	(0018,1111)		ALWAYS	AUTO
Estimated Radiographic Magnification Factor	(0018,1114)	Non-Mag Images: 1.073 default Mag Images: 1.5 or, 1.8 or, 2.0	ALWAYS	AUTO
Exposure Time	(0018,1150)	From x-ray system	ALWAYS	AUTO
X-ray Tube Current	(0018,1151)	From x-ray system	ALWAYS	AUTO
Exposure	(0018,1152)	From x-ray system	ALWAYS	AUTO
Exposure in uAs	(0018,1153)	From x-ray system	ALWAYS	AUTO
Filter Type	(0018,1160)	STRIP	ALWAYS	AUTO
Focal Spot	(0018,1190)		ALWAYS	AUTO
Anode Target Material	(0018,1191)	MOLYBDENUM RHODIUM TUNGSTEN	ALWAYS	AUTO
Body Part Thickness	(0018,11A0)	From x-ray system	ALWAYS	AUTO
Compression Force	(0018,11A2)	From x-ray system	ALWAYS	AUTO
Relative X-Ray Exposure	(0018,1405)		ALWAYS	AUTO
Positioner Type	(0018,1508)	MAMMOGRAPHIC	ALWAYS	AUTO
Positioner Primary Angle	(0018,1510)		ALWAYS	AUTO
View Position	(0018,5101)	User selects view to acquire	ALWAYS	AUTO, USER
Detector Temperature	(0018,7001)		ALWAYS	AUTO
Detector Type	(0018,7004)	DIRECT	ALWAYS	AUTO
Detector ID	(0018,700A)		ALWAYS	AUTO
Date of Last Detector Calibration	(0018,700C)		ALWAYS	AUTO
Detector Binning	(0018,701A)	2 2	ALWAYS	AUTO
Field of View Origin	(0018,7030)		ALWAYS	AUTO
Field of View Rotation	(0018,7032)		ALWAYS	AUTO
Field of View Horizontal Flip	(0018,7034)		ALWAYS	AUTO
Filter Material	(0018,7050)	ALUMINIUM COPPER LEAD MOLYBDENUM RHODIUM SILVER TIN	ALWAYS	AUTO

Attribute Name	Tag	Value	Presence of Value	Source
Filter Thickness Minimum	(0018,7052)		ALWAYS	AUTO
Filter Thickness Maximum	(0018,7054)		ALWAYS	AUTO
Exposure Control Mode	(0018,7060)	MANUAL AUTOMATIC	ALWAYS	AUTO
Exposure Control Mode Description	(0018,7062)	From x-ray system	ALWAYS	AUTO
Exposure Time in μ S	(0018,8150)	From x-ray system	ALWAYS	AUTO
Frame of Reference UID	(0020,0052)		ALWAYS	AUTO
Breast Implant Present	(0028,1300)	YES, NO	ALWAYS	AUTO, USER
Entrance Dose	(0040,0302)		ALWAYS	AUTO
Half Value Layer	(0040,0314)		ALWAYS	AUTO
Organ Dose	(0040,0316)		ALWAYS	AUTO
Organ Exposed	(0040,0318)	BREAST	ALWAYS	AUTO
Entrance Dose in mGy	(0040,8302)		ALWAYS	AUTO
View Code Sequence	(0054,0220)	One from CID 4014: CC, MLO, LM, ML, LMO, SIO, ISO, FB, XCCL, XCCM	ALWAYS	AUTO, USER
> Code Value	(0008,0100)			
> Code Scheme Designator	(0008,0102)			
> Code Meaning	(0008,0104)			
>View Modifier Code Sequence	(0054,0222)	Zero or more from CID 4015: M, S, RL, RM, CV, AT, TAN, ID, RI, RS, NP, AC, IMF,AX (M)agnification and/or (S)pot compression is based on the compression paddle	VNAP	AUTO, USER
>> Code Value	(0008,0100)			
>> Code Scheme Designator	(0008,0102)			
>> Code Meaning	(0008,0104)			

7.5.2 Breast Tomosynthesis Image Storage SOP Class

By default the Breast Tomosynthesis Image Storage SOP Class is Standard Extended by the attributes defined in Table 7.5.2-1. The attributes contained in created SOP Instances are configurable.

Table 7.5.2-1

STANDARD EXTENDED ATTRIBUTES OF CREATED BREAST TOMOSYNTHESIS IMAGE SOP INSTANCES

Attribute Name	Tag	Value	Presence of Value	Source
Irradiation Event UID	(0008,3010)		ALWAYS	AUTO
Patient Orientation	(0020,0020)	Pixel data orientation can be configured to match the user selected hanging protocol (dorsal or ventral).	ALWAYS	AUTO

7.5.3 CT Image Storage SOP Class

By default the CT Image Storage SOP Class is Standard Extended by the attributes defined in Table 7.5.3-1 that are copied from the source projections. The attributes contained in created SOP Instances are configurable.

Table 7.5.3-1

STANDARD EXTENDED ATTRIBUTES OF CREATED CT IMAGE SOP INSTANCES

Attribute Name	Tag	Value	Presence of Value	Source
Estimated Radiographic Magnification Factor	(0018,1114)			
Filter Type	(0018,1160)		ALWAYS	AUTO
Grid	(0018,1166)			
Anode Target Material	(0018,1191)		ALWAYS	AUTO
Body Part Thickness	(0018,11A0)		ALWAYS	AUTO
Compression Force	(0018,11A2)		ALWAYS	AUTO
Paddle Description	(0018,11A4)		ALWAYS	AUTO
Relative X-Ray Exposure	(0018,1405)		ALWAYS	AUTO
Positioner Primary Angle	(0018,1510)		ALWAYS	AUTO
Detector Temperature	(0018,7001)		ALWAYS	AUTO
Detector Type	(0018,7004)		ALWAYS	AUTO
Detector ID	(0018,700A)		ALWAYS	AUTO
Date of Last Detector Calibration	(0018,700C)		ALWAYS	AUTO
Time of Last Detector Calibration	(0018,700E)		ALWAYS	AUTO
Detector Binning	(0018,701A)		ALWAYS	AUTO
Field of View Origin	(0018,7030)			
Field of View Rotation	(0018,7032)			
Field of View Horizontal Flip	(0018,7034)			
Filter Material	(0018,7050)		ALWAYS	AUTO
Filter Thickness Minimum	(0018,7052)			
Filter Thickness Maximum	(0018,7054)			
Exposure Control Mode	(0018,7060)		ALWAYS	AUTO
Exposure Control Mode Description	(0018,7062)		ALWAYS	AUTO
Image Laterality	(0020,0062)		ALWAYS	AUTO
Breast Implant Present	(0028,1300)		ALWAYS	AUTO, USER
Half Value Layer	(0040,0314)		ALWAYS	AUTO
Organ Dose	(0040,0316)		ALWAYS	AUTO
Entrance Dose in mGy	(0040,8302)		ALWAYS	AUTO
View Code Sequence	(0054,0220)	One Item	ALWAYS	AUTO, USER
>View Modifier Code Sequence	(0054,0222)	Zero or more Items	VNAP	AUTO, USER

7.6 Private Transfer Syntaxes

None.