



Artwork consists of:

- 7.50-inch x 3.0 -inch sheets

Artwork master contains the following file(s):

File Name	Description
AW-21052-002_001_02.zip	Source and Supplier File
AW-21052-002_001_02.pdf	View File

Artwork prints in black and white

REV AUTHORED BY S VAILLANCOURT	DATE 02/07/20	 	
REV DRAFTED BY S VAILLANCOURT	DATE 02/07/20		
PROPRIETARY: This document contains proprietary data of Hologic, Inc. No disclosure, reproduction or use of any part thereof may be made except by written permission from Hologic.	TITLE <b>ARTWORK, CERVICAL SEAL, EN</b>	DOCUMENT NUMBER <b>AW-21052-002</b>	REV 001
REV. RELEASE DATE: 4 MAR 2020		SIZE A	SHEET 1 OF 1

## Instructions for Use

### Description

The Omni™ Lok cervical seal is used during a hysteroscopic procedure to minimize liquid distention media leakage from the cervix. The Omni Lok cervical seal is a sterile, single use, disposable device that slides over the distal end of a hysteroscope, such as the Hologic MyoSure Classic hysteroscope, Hologic MyoSure XL hysteroscope or the Omni hysteroscope operative sheaths. The cervical seal device is introduced along with the hysteroscope into the vagina. As the hysteroscope is inserted through the cervix and into the uterus during hysteroscopic procedures, the cervical seal device remains seated at the opening of the cervix, using spring loaded pressure. The cervical seal tip remains flush against the cervical opening throughout the duration of the procedure to create a seal. This seal minimizes fluid leakage from the cervix.

This device can be used anywhere hysteroscopic procedures are performed including Hospitals, Doctor's Office or Ambulatory Surgery Centers.

### Indications for Use

The Omni Lok cervical seal is used during a hysteroscopic procedure to minimize liquid distention media leakage from the cervix.

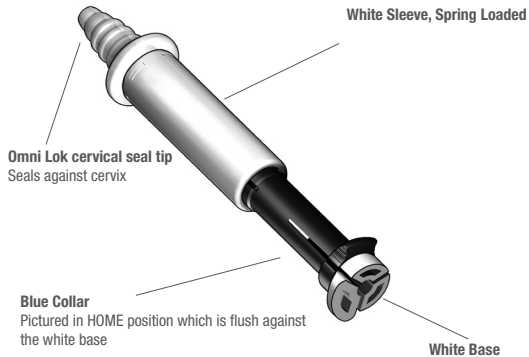

Figure 1

## Contraindications

The Omni Lok cervical seal should not be used in a patient with contraindications to hysteroscopy.

## Warnings

The operating instructions in this guide will make the system easier to use. As with any surgical instrument, there are important health and safety considerations. These are as follows:

- Before using the Omni Lok cervical seal for the first time, please review all available product information.
- Before using the Omni Lok cervical seal you should be experienced in hysteroscopic surgery.
- Please refer to the instructions for use for your hysteroscope for additional important safety information regarding hysteroscopy.

## Precautions

Federal law restricts this device to sale by or on the order of a physician. **Rx ONLY**

- The Omni Lok cervical seal should be stored at room temperature, away from moisture and direct heat.
- Do not use after expiration date.
- Do not use the device if the sterile package is open or appears compromised. Do not use the device if damage is observed.
- The Omni Lok cervical seal is intended for single use only. Do not re-sterilize. Do not lubricate the Omni Lok cervical seal. Discard the Omni Lok cervical seal after use.
- Use of a reprocessed, single-use Omni Lok cervical seal may permanently damage, impede performance, or cause failure of the Omni Lok cervical seal. Use of such products may render any warranties null and void.
- If the position of the cervical seal is changed from Extended to Home or Home to Extended, the scope should be stabilized. Ensure there is always clear field of view prior to adjusting the cervical seal position.

- The Omni Lok cervical seal is only compatible with the Hologic operative hysteroscopes in the Table below:

**Operative Hysteroscope****Part Number**

Omni Hysteroscope with Omni 5.5 Operative Sheath

60-200, 60-202

Omni Hysteroscope with Omni 6.0 Operative Sheath

60-200, 60-203

MyoSure Rod Lens Hysteroscope

40-250

MyoSure XL Rod Lens Hysteroscope

50-250XL, Note: Cervical Seal tip requires cutting, reference Figure 2

**Set- up:**

The Omni Lok cervical seal is provided EtO sterilized. Verify that the device is sterile prior to use by verifying expiration date and package integrity. Do not use if the product is damaged or if the package is opened or damaged or if the package is expired. The tip does not require modification when used with the Omni Hysteroscope with 5.5 Sheath, Omni Hysteroscope with 6.0 Sheath and MyoSure Rod Lens Hysteroscope.

**For 50-250XL MyoSure XL Rod Lens Hysteroscope only:**

The tip needs to be trimmed in order to accommodate the larger scope diameter of the MyoSure XL Rod Lens Hysteroscope. Use scissors to cut the proximal end of the seal tip at the location on the first rib as indicated in Figure 2. If the device is not cut in this location, it cannot be used with the 50-250XL MyoSure XL Hysteroscope. Inspect the tip following trimming to ensure there is no extra hanging material, no rough edges, etc. prior to use.

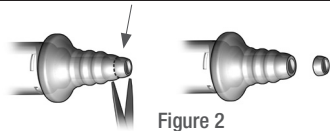

Figure 2

Follow standard procedures for setting up operative hysteroscopy.

## Operation

1. For all compatible Hysteroscopes:

Simply slide the proximal end of the cervical seal onto the distal end of the hysteroscope. Hold the device by aligning the white spring loaded sleeve and blue collar in one hand as shown in Figure 3. To allow for ease of entry, angle the hysteroscope slightly as it's introduced to the white base.

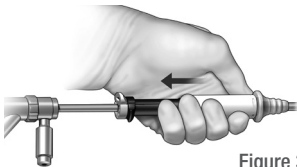

Figure 3

NOTE: The white base of the cervical seal device will expand to accommodate the hysteroscope diameter as shown in Figure 4. The cervical seal grips the hysteroscope, but does not “lock” on the scope. The device will not slide any further on the hysteroscope once it is flush with the hysteroscope as shown in Figure 5 on the following page.

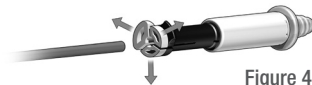

Figure 4

2. Advance the cervical seal to the desired location on the scope based on user preference. At a minimum the scope should protrude slightly from the distal end of the cervical seal prior to advancing the hysteroscope into the external os.



Figure 5

NOTE: The orientation of the cervical seal on the hysteroscope does not matter.

The blue tab and white tab must maintain the orientation as shown in Figure 6 below. This should not be changed from the configuration that is in the pouch as shown in Figure 6 and 7.

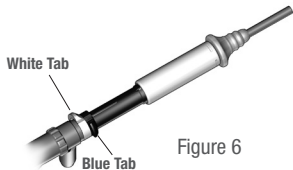

Figure 6



Figure 7

NOTE: DO NOT Twist or Rotate the tabs with respect to each other as shown in Figure 8.

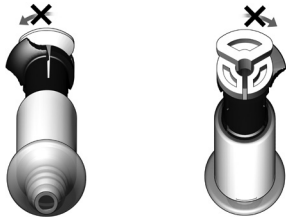

Figure 8

3. Once the Omni Lok cervical seal is seated on the hysteroscope, under visualization from the monitor as needed, introduce the Omni Lok cervical seal and hysteroscope transvaginally. Refer to the hysteroscope IFU for further instructions operation or use of the hysteroscope.

4. Insert the scope and cervical seal tip into the cervix ensuring that the cervical seal tip stays flush against the external os of the cervix as shown in Figure 9. This creates a seal and minimizes leakage of distention media.
5. Perform the hysteroscopic procedure following standard operating procedures.

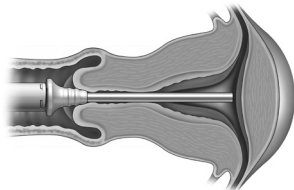

Figure 9



6. To extend the overall length of the cervical seal, an optional device feature can be used.

Figure 10  
"HOME" position, as packaged

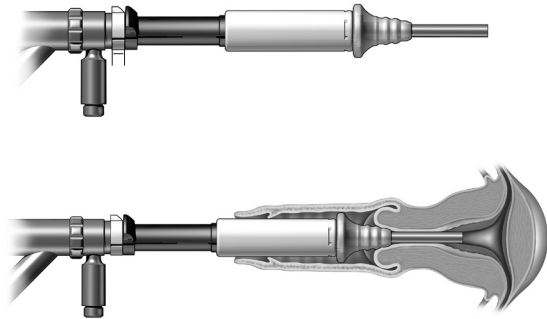
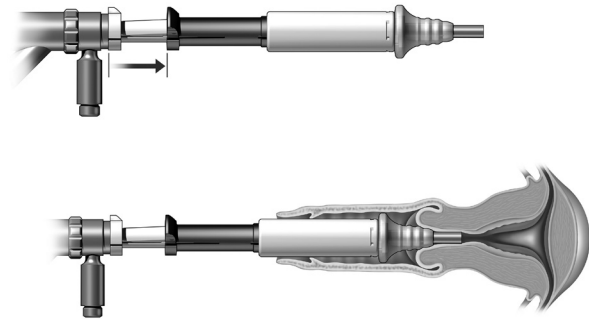

Figure 11  
"EXTENDED"



To change the cervical seal from the “**HOME**” configuration (as packaged in the pouch, Figure 10) to the “**EXTENDED**” position (Figure 11),

a. Under visualization, hold the hysteroscope with one hand. Ensure the white base is flush against the hysteroscope.

Place a finger or thumb on the **white tab** of the base with the same hand that is holding the scope to secure the **white tab**.

b. With the other hand, push the **blue tab** on the blue collar forward (Figure 12) until it locks into the “**EXTENDED**” position shown in Figure 11.

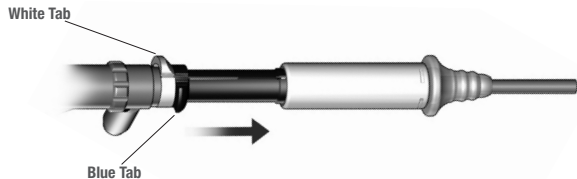

Figure 12

7. To change the cervical seal from the “**EXTENDED**” position to the “**HOME**” position:

a. Under visualization, hold the hysteroscope with one hand. Ensure that the white base is flush against the hysteroscope.

Place a finger or thumb on the **white tab** of the base with the same hand that is holding the hysteroscope.

b. As shown in Figure 13, with the other hand, (1)grasp the **blue tab** and lift it up and over the step on the white base. (2)Slide the **blue tab** to the “**HOME**” position, until it is flush with the white base

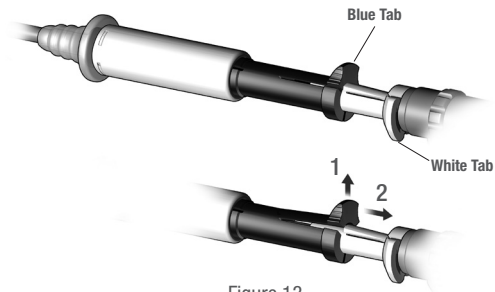

Figure 13

## Ending the Procedure

At end of procedure, remove the hysteroscope and Omni Lok cervical seal from the patient as one unit by holding the blue collar and white sleeve during removal.

## Disposal

Dispose of the Omni Lok cervical seal according to facility policies and procedures for biohazardous materials.

## Storage

The Omni Lok cervical seal should be stored at room temperature, away from moisture and direct heat.

## Sterility

The Omni Lok cervical seal is EtO sterilized. DO NOT RE-STERILIZE. DO NOT REUSE. Do not use if package is opened or damaged. Discard all opened, unused devices.

## Warranty

Except as otherwise expressly stated in the Agreement: i) Equipment manufactured by Hologic is warranted to the original Customer to perform substantially in accordance with published product specifications for one (1) year starting from the date of shipment, or if Installation is required, from the date of Installation (“Warranty Period”); ii) digital imaging mammography x-ray tubes are warranted for twenty-four (24) months, during which the x-ray tubes are fully warranted for the first twelve (12) months and are warranted on a straight-line prorated basis during months 13-24; iii) replacement parts and remanufactured items are warranted for the remainder of the Warranty Period or ninety (90) days from shipment, whichever is longer; iv) consumable Supplies are warranted to conform to published specifications for a period ending on the expiration date shown on their respective packages; v) licensed Software is warranted to operate in accordance with published specifications; vi) Services are warranted to be supplied in a workman-like manner; vii) non-Hologic Manufactured Equipment is warranted through its manufacturer and such manufacturer’s warranties shall extend to Hologic’s customers, to the extent permitted by the manufacturer of such non-Hologic Manufactured Equipment. Hologic does not warrant that use of Products will be uninterrupted or error-free, or that Products will operate with non-Hologic authorized third-party products.

These warranties do not apply to any item that is: (a) repaired, moved, or altered other than by Hologic authorized service personnel; (b) subjected to physical (including thermal or electrical) abuse, stress, or misuse; (c) stored, maintained, or operated in any manner inconsistent with applicable Hologic specifications or instructions, including Customer's refusal to allow Hologic recommended Software upgrades; or (d) designated as supplied subject to a non-Hologic warranty or on a pre-release or "as-is" basis.

## Technical Support Information

For Technical Support or reorder information in the United States, please contact:



Hologic, Inc.  
250 Campus Drive  
Marlborough, MA 01752 USA  
Phone: 1-800-442-9892  
[www.hologic.com](http://www.hologic.com)





International customers, contact your distributor or local Hologic Sales Representative:



European Representative:  
Hologic BVBA  
Da Vincilaan 5  
1930 Zaventem  
Belgium  
Tel: +32 2 711 46 80

## Symbols

Symbol	Description
	Manufacturer
	Authorized representative in the European Community
	Caution: Federal law restricts this device to sale by or on the order of a physician
	Consult instructions for use
	Patient contact parts not made with DEHP

	Do not re-sterilize
	Do not use if package is damaged
	Do not re-use
	Sterilized using ethylene oxide
	CE marking of conformity with notified body identification number