

Affirm[®]

Breast Biopsy Guidance System



User Guide

MAN-06411-002 Revision 003

HOLOGIC[®]

Affirm[®]

Breast Biopsy Guidance System

User Guide

For Software Versions 1.11 and 2.2

Part Number MAN-06411-002

Revision 003

July 2021

HOLOGIC[®]

Product Support

USA: +1.877.371.4372

Europe: +32 2 711 4690

Asia: +852 37487700

Australia: +1 800 264 073

All Other: +1 781 999 7750

Email: BreastHealth.Support@hologic.com

© 2020-2001 Hologic, Inc. Printed in the USA. This manual was originally written in English.

Hologic, 3Dimensions, Affirm, ATEC, Brevera, Dimensions, Eviva, Selenia, and associated logos are trademarks and/or registered trademarks of Hologic, Inc., and/or its subsidiaries in the United States and/or other countries. All other trademarks, registered trademarks, and product names are the property of their respective owners.

This product may be protected by one or more U.S. or foreign patents as identified at www.Hologic.com/patent-information.

Table of Contents

List of Figures	ix
List of Tables	xi
1: Introduction	1
1.1 Intended Use.....	1
1.2 User Profiles.....	1
1.2.1 Mammography Technologist.....	1
1.2.2 Radiologists, Surgeons.....	1
1.2.3 Medical Physicist.....	2
1.3 Training Requirements.....	2
1.4 Quality Control Requirements.....	2
1.5 Where to Find Technical Description Information.....	2
1.6 Warranty Statement.....	3
1.7 Technical Support.....	3
1.8 Product Complaints.....	3
1.9 Hologic Cybersecurity Statement.....	3
1.10 Symbols.....	4
1.11 Descriptions of Warnings, Cautions, and Notes.....	5
2: General Information	7
2.1 System Overview.....	7
2.2 How to Handle the Biopsy Guidance Module.....	8
2.3 Safety Information.....	9
2.4 Warnings and Precautions.....	9
2.5 Compliance.....	10
2.5.1 Compliance Requirements.....	10
2.6 Label Locations.....	11
3: Installation, Verification, and Removal	13
3.1 Biopsy Guidance Module Components.....	13
3.2 Biopsy Control Module Components.....	15
3.3 Installation of the Main Components.....	16
3.3.1 Attach the Biopsy Guidance Module.....	16
3.3.2 Attach the Biopsy Control Module.....	17
3.4 Installation and Removal of Accessories.....	18
3.4.1 Biopsy Compression Paddles.....	18
3.4.2 Needle Guide.....	18
3.4.3 Biopsy Device Adapter.....	20
3.4.4 Biopsy Device.....	20
3.4.5 Lateral Arm and Lateral Arm Accessories.....	21

Affirm Breast Biopsy Guidance System User Guide

Table of Contents

3.5	System Verifications	36
3.5.1	Confirm the Host Connection.....	36
3.6	Removal of the Main Components.....	37
3.6.1	Biopsy Control Module.....	37
3.6.2	Biopsy Guidance Module	37
3.7	Tabletop Stand for the Affirm System	38
3.8	Storage Case for the Lateral Arm.....	39
4: User Interface - Biopsy Control Module		41
4.1	Biopsy Control Module Screens.....	41
4.1.1	Home Screen.....	41
4.1.2	Target Guidance Screen	42
4.1.3	Jog Mode Screen.....	46
4.1.4	Select Target Screen.....	48
5: Biopsy		51
5.1	Biopsy Views	51
5.1.1	Add a Biopsy View.....	52
5.1.2	Edit a Biopsy View	54
5.2	C-Arm Stereo Modes	55
5.2.1	C-Arm Rotation in the C-Arm Stereo Modes.....	55
5.2.2	How to Select the C-Arm Stereo Mode for Image Acquisition	57
5.3	Biopsy Tab.....	58
5.3.1	Biopsy Options.....	59
5.4	Stereotactic 2D Lesion Targeting	62
5.4.1	Verify the Position of the Biopsy Device	63
5.5	Lesion Targeting with Tomosynthesis Guidance	64
5.5.1	Verify the Position of the Biopsy Device	65
5.5.2	Project Targets on Post-Fire Scout Image	65
5.6	Lesion Targeting Using Multi-Pass	66
5.7	Post Biopsy.....	70
5.8	Printing Stereo Pair Images	70
6: Quality Control		71
6.1	Required Quality Control Procedures	71
6.2	QAS Test.....	71
6.2.1	QAS Test for Standard Needle Approach.....	72
6.2.2	QAS Test for Lateral Needle Approach.....	75
6.3	Geometry Calibration.....	78
6.3.1	Geometry Calibration Procedure.....	78
7: Care and Cleaning		79
7.1	General Information	79
7.2	Preventive Maintenance Schedule.....	79
7.3	Service Preventive Maintenance Schedule	81

7.4	For General Cleaning	82
7.4.1	How to Clean the Biopsy Control Module Screen	82
7.4.2	To Prevent Possible Injury or Equipment Damage.....	83
Appendix A: System Specifications		85
A.1	Affirm System Measurements.....	85
A.2	Lateral Arm Measurements.....	86
A.3	Biopsy Guidance Module	87
A.4	Lateral Arm.....	87
A.5	Biopsy Control Module.....	87
Appendix B: System Messages and Alerts		89
B.1	Audible Alerts.....	89
B.2	Error Messages	89
B.3	Acquisition Workstation Messages	91
Appendix C: CNR Correction for Biopsy		93
C.1	CNR Correction for Stereotactic 2D Biopsy	93
C.1.1	AEC Table 0 (Standard Stereotactic 2D Biopsy Dose)	93
C.2	CNR Correction for Biopsy Under Tomosynthesis Option	93
C.2.1	AEC Table 0 (Tomosynthesis Option: Standard Tomo Dose)	93
Appendix D: Forms		95
D.1	QAS Test Checklist	95
D.2	QAS Test Checklist for the Lateral Arm	96
Appendix E: Ancillary Parts for Biopsy		97
E.1	Hologic Factory-Verified Biopsy Devices.....	97
E.2	Wire Localization Needle Guides.....	98
Glossary of Terms		99
Index		101

List of Figures

Figure 1: Affirm Biopsy System on the Selenia Dimensions Mammography System	7
Figure 2: How to Lift the Biopsy Guidance Module	8
Figure 3: How to Store the Biopsy Guidance Module	8
Figure 4: Biopsy Guidance Module Label Location	11
Figure 5: Lateral Arm Serial Number Label Location.....	11
Figure 6: Biopsy Guidance Module.....	13
Figure 7: Biopsy Control Module	15
Figure 8: Installation of the Biopsy Guidance Module	16
Figure 9: Attachment of the Biopsy Control Module.....	17
Figure 10: Installation of the Needle Guide Holder on the Standard Device Mount.....	19
Figure 11: Installation of the Needle Guide on the Standard Needle Guide Holder	19
Figure 12: Attaching a Biopsy Device Adapter to the Device Mount (Standard).....	20
Figure 13: Lateral Arm Components.....	21
Figure 14: Left Needle Approach of Lateral Arm (Blue).....	23
Figure 15: Right Needle Approach of Lateral Arm (Yellow).....	23
Figure 16: Installing the Lateral Arm Stand over the Image Receptor	24
Figure 17: Removing the Needle Guide Holder from the Standard Device Mount	25
Figure 18: Installing the Lateral Arm on the Device Mount	26
Figure 19: Selection Screen for the Lateral Arm Mounting Side	27
Figure 20: Attaching the Blue Needle Guide Holder to the Needle Guide Rods (Left Needle Approach).....	28
Figure 21: Attaching the Yellow Needle Guide Holder to the Needle Guide Rods (Right Needle Approach).....	28
Figure 22: Installing a Disposable Needle Guide on a Needle Guide Holder (Lateral Arm).....	29
Figure 23: Carriage Lever Locked and Unlocked Positions.....	30
Figure 24: Locked and Unlocked Positions of Device Mount Lever.....	30
Figure 25: Installing Device Mount onto Lateral Arm Carriage	31
Figure 26: Attaching the Biopsy Device Adapter to the Device Mount (Lateral Arm)	32
Figure 27: Lock Levers in Fully Locked Position.....	33
Figure 28: Scales and Positioning for the X-Stop and Carriage	34
Figure 29: Installing the X-Stop on the Lateral Arm	35
Figure 30: Home Screen on the Biopsy Control Module.....	36
Figure 31: Affirm System Tabletop Stand	38
Figure 32: Lateral Arm and Storage Case.....	39
Figure 33: Home Screen	41
Figure 34: Target Guidance Screen.....	42
Figure 35: Target Guidance Screen for Lateral Arm	43
Figure 36: Green Differential Cells	44
Figure 37: Yellow and Red Cells.....	44
Figure 38: Alert Sounds Are Audible.....	45
Figure 39: Alert Sounds Are Muted	45
Figure 40: Jog Mode Screen	46
Figure 41: Jog Mode Screen for Lateral Arm.....	47
Figure 42: Select Target Screen.....	48

Affirm Breast Biopsy Guidance System User Guide

Table of Contents

Figure 43: Select Target Screen for Lateral Arm	49
Figure 44: Biopsy Tab in the Add View Screen	52
Figure 45: Stereo (-) and Stereo (+) View Modifiers	53
Figure 46: Edit (Biopsy) View Screen.....	54
Figure 47: Stereo Mode.....	56
Figure 48: C-arm Mode	56
Figure 49: System Status Icon.....	57
Figure 50: System Status Menu	57
Figure 51: System Defaults Screen.....	57
Figure 52: The Biopsy Tab	58
Figure 53: Function Buttons and Data on the Biopsy Tab (Standard Needle Approach)	59
Figure 54: Function Buttons and Data on the Biopsy Tab (Lateral Needle Approach).....	59
Figure 55: Multi-Pass Options.....	66
Figure 56: Four Offset Target Points Established Around Center Target Point.....	67
Figure 57: 3 mm Spacing of Offset Points.....	67
Figure 58: 5 mm Spacing of Offset Points.....	67
Figure 59: Single Point Target Selected.....	68
Figure 60: Single Point Target Deselected	68
Figure 61: Multi-Pass Target Selected	68
Figure 62: Multi-Pass Target Deselected.....	68
Figure 63: Biopsy Order of Target Sets	69
Figure 64: Biopsy Order of a Three Offset Target.....	69
Figure 65: Biopsy Order of a Four Offset Target	69
Figure 66: Biopsy Order of a Five Offset Target	69
Figure 67: Stereo Pair Print Screen	70
Figure 68: QAS Button on the Admin Screen.....	72
Figure 69: QAS Test Info Dialog Box.....	73
Figure 70: Device Field in the Biopsy Tab	73
Figure 71: Lateral QAS Button on the Admin Screen	75
Figure 72: Lateral QAS Test Info Dialog Box	76
Figure 73: Device Field in the Biopsy Tab	76
Figure 74: Affirm Biopsy Guidance Module.....	85
Figure 75: Lateral Arm	86

List of Tables

Table 1: Components of the Biopsy Guidance Module	14
Table 2: Components of the Biopsy Control Module.....	15
Table 3: Components of the Lateral Arm	22
Table 4: How to Use the Sound Button	45
Table 5: The C-arm Stereo Mode Button	56
Table 6: How to Select the C-Arm Stereo Mode	57
Table 7: Required Procedures	71
Table 8: Radiologic Technologist Preventive Maintenance Schedule.....	79
Table 9: Radiologic Technologist Preventive Maintenance Schedule.....	80
Table 10: Service Engineer Preventive Maintenance Schedule	81
Table 11: Affirm System Audible Alerts.....	89
Table 12: Affirm System Error Messages.....	89
Table 13: Acquisition Workstation Messages	91
Table 14: Hologic Factory-Verified Biopsy Devices.....	97
Table 15: Wire Localization (Loc) Needle Guides	98

Chapter 1 Introduction

Read all this information carefully before operating the system. Follow all warnings and precautions as stated in this manual. Keep this manual available during procedures. Physicians should tell patients about all potential risks and adverse events described in this manual with respect to the operation of the system.



Note

Hologic configures some systems to meet specific requirements. Your system configuration may not have all the options and accessories included in this manual.

1.1 Intended Use

Rx Only Caution: United States federal law restricts this device to sale by or on the order of a physician.

The Affirm® breast biopsy guidance system is an optional accessory for the Selenia® Dimensions® and 3Dimensions™ digital mammography and digital tomosynthesis systems. Its function is to localize lesions accurately in the breast in three dimensions. It is intended to provide targeting guidance for interventional procedures such as biopsy, presurgical localization, or treatment devices.

1.2 User Profiles

1.2.1 Mammography Technologist

- Meets all requirements that apply to the location in which the Mammography Technologist operates.
- Completed training on the mammography system.
- Has training in mammography positions.
- Understands stereotactic breast biopsy procedures.
- Understands how to operate a computer and its peripherals.
- Can lift 20 pounds to shoulder height with two hands (necessary for upright stereotactic systems).
- Understands sterile procedures.

1.2.2 Radiologists, Surgeons

- Meets all requirements that apply to the location in which the Physician operates.
- Understands stereotactic breast biopsy procedures.
- Understands how to operate a computer and its peripherals.
- Understands sterile procedures.
- Gives local anesthesia.
- Understands basic surgical procedures for core biopsy.

1.2.3 Medical Physicist

- Meets all requirements that apply to the location in which the Medical Physicist operates.
- Understands mammography.
- Has experience with digital imaging.
- Understands how to operate a computer and its peripherals.

1.3 Training Requirements

In the United States, users must be Registered Radiologic Technologists meeting criteria to perform mammography. The mammography users must meet all applicable MQSA personnel requirements under FDA guidelines for conventional and digital mammography.

The user has options available for training, which include but are not limited to:

- Onsite applications training by a Hologic Clinical Services Specialist
- Onsite on the job training also known as peer training

Additionally, the user manual is a guide for directions on how to use the system.

All users must make sure that they receive training on correct operation of the system before use on patients.

Hologic does not accept the responsibility for injury or damage from incorrect system operation.

1.4 Quality Control Requirements

Perform all Quality Control tests within the correct time frame.

1.5 Where to Find Technical Description Information

Technical description information is available in the *Service Manual*.

1.6 Warranty Statement

Except as otherwise expressly stated in the Agreement: i) Equipment manufactured by Hologic is warranted to the original Customer to perform substantially in accordance with published product specifications for one (1) year starting from the date of shipment, or if Installation is required, from the date of Installation (“Warranty Period”); ii) digital imaging mammography x-ray tubes are warranted for twenty-four (24) months, during which the x-ray tubes are fully warranted for the first twelve (12) months and are warranted on a straight-line prorated basis during months 13-24; iii) replacement parts and remanufactured items are warranted for the remainder of the Warranty Period or ninety (90) days from shipment, whichever is longer; iv) consumable Supplies are warranted to conform to published specifications for a period ending on the expiration date shown on their respective packages; v) licensed Software is warranted to operate in accordance with published specifications; vi) Services are warranted to be supplied in a workman-like manner; vii) non-Hologic Manufactured Equipment is warranted through its manufacturer and such manufacturer’s warranties shall extend to Hologic’s customers, to the extent permitted by the manufacturer of such non-Hologic Manufactured Equipment. Hologic does not warrant that use of Products will be uninterrupted or error-free, or that Products will operate with non-Hologic authorized third-party products. These warranties do not apply to any item that is: (a) repaired, moved, or altered other than by Hologic authorized service personnel; (b) subjected to physical (including thermal or electrical) abuse, stress, or misuse; (c) stored, maintained, or operated in any manner inconsistent with applicable Hologic specifications or instructions, including Customer’s refusal to allow Hologic recommended Software upgrades; or (d) designated as supplied subject to a non-Hologic warranty or on a pre-release or “as-is” basis.

1.7 Technical Support

Refer to the copyright page of this manual for contact information for product support.

1.8 Product Complaints

Report any complaints or problems in the quality, reliability, safety, or performance of this product to Hologic. If the device has caused or added to patient injury, immediately report the incident to Hologic. (Refer to the copyright page for contact information.)











1.9 Hologic Cybersecurity Statement

Hologic continuously tests the current state of computer and network security to examine possible security problems. When necessary, Hologic provides the updates to the product.

For Cybersecurity Best Practices documents for Hologic products, refer to the Hologic Internet site at www.Hologic.com.

1.10 Symbols

This section describes the Symbols on this system.

	Potential Equalization terminal
	Protective Earth terminal
	"On" and "Off" (power) for the computer and display.
	Discard electrical and electronic equipment separately from standard waste. Send decommissioned material to Hologic or contact your service representative.
	Manufacturer
	Date of Manufacture
	Catalog number
	Serial number
	Caution
	Follow operating instructions

1.11 Descriptions of Warnings, Cautions, and Notes

Descriptions of Warnings, Cautions, and Notes used in this manual:



WARNING!

The procedures that you must follow accurately to prevent possible dangerous or fatal injury.



Warning:

The procedures that you must follow accurately to prevent injury.



Caution:

The procedures that you must follow accurately to prevent damage to equipment, loss of data, or damage to files in software applications.



Note

Notes show additional information.

Chapter 2 General Information

2.1 System Overview

The Affirm breast biopsy guidance system attaches to the C-arm of the Selenia Dimensions system or the 3Dimensions system. The Affirm biopsy system has two main components:

- Biopsy Guidance Module
- Biopsy Control Module

A compatible biopsy device attaches to the biopsy guidance module device mount. During a standard needle approach procedure, motors in the Affirm system move the biopsy device in X and Y directions. Z-axis movement is manual. The optional Affirm Lateral Arm Upright Biopsy Accessory installs on the biopsy guidance module to enable lateral needle approach procedures. When using the lateral arm accessory, X-, Y-, and Z-axis movement is the same as for standard needle approach. The C-arm is positioned at 0° and the biopsy device is positioned the same way as in a standard needle approach. Then the needle is manually advanced into the breast along its own X-axis, referred to as “Lat X.”

The Tube Arm on the Selenia Dimensions and 3Dimensions systems moves separately from the Compression Arm to permit the acquisition of 2D and tomosynthesis images for targeting. The types of images you can acquire are contingent on your imaging system licensing. Refer to the imaging system *User Guide* for complete information about that system. The types of biopsies you can perform are contingent on your Affirm system licensing. To see all your installed licenses, go to **Licensing** in **System Tools**.

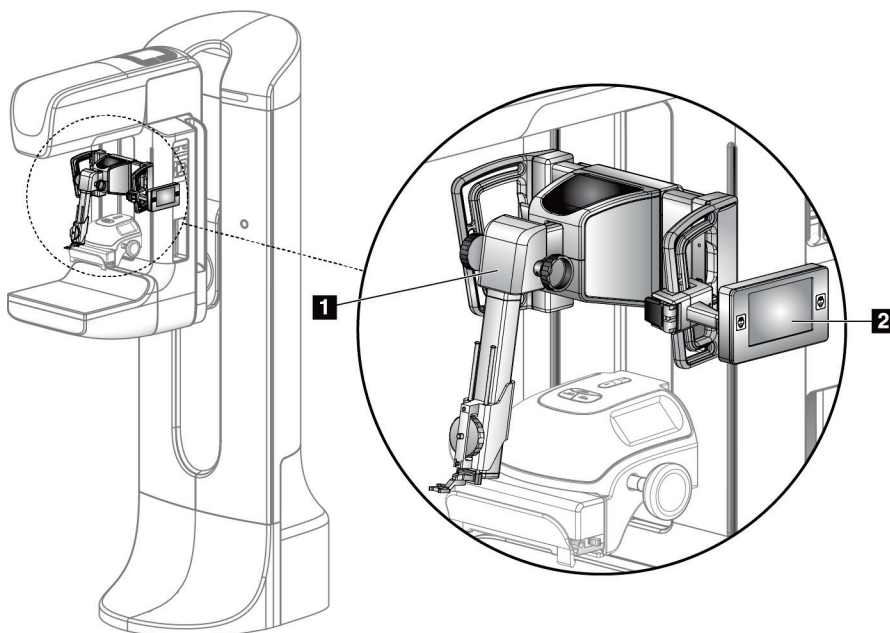

Figure Legend

1. Biopsy Guidance Module
2. Biopsy Control Module

Figure 1: Affirm Biopsy System on the Selenia Dimensions Mammography System

2.2 How to Handle the Biopsy Guidance Module



Caution:

To prevent damage or alignment problems with the Needle Guidance Stage, be careful when you move the Biopsy Guidance Module.



Caution:

The Affirm Biopsy Guidance Module weighs 15 pounds. When you move it, be sure to have a secure grip on the handles.

Only lift the Biopsy Guidance Module with the handles.

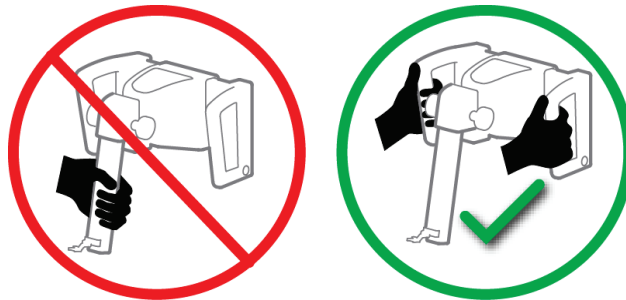

Figure 2: How to Lift the Biopsy Guidance Module

When the Biopsy Guidance Module is not in use, put the device on its back.

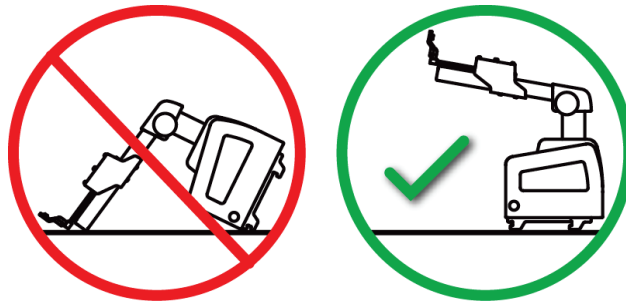

Figure 3: How to Store the Biopsy Guidance Module

2.3 Safety Information

Read and understand this manual before you use the system. Keep the manual available during the patient procedures.

Always follow all the instructions in this manual. Hologic does not accept the responsibility for injury or damage from incorrect system operation. Hologic can schedule training at your facility.

The system has protective devices, but the Technologist must understand how to safely use the system. The Technologist must remember the health hazards of x rays.

Do not connect this equipment to any system or component not described in this manual. A combination of components must have the data to validate the safety of the patient, personnel, and the environment. Any additional certification becomes the responsibility of the user.

2.4 Warnings and Precautions



WARNING!

After power failure, remove the patient from the system before you apply power.



Warning:

You make x rays when you use the procedures in this manual.



Warning:

C-arm movement is motorized.



Warning:

The Tube Arm movement is motorized.



Warning:

Only qualified users can use this system.



Warning:

Only physicians and providers trained in percutaneous biopsy procedures can use this system.



Warning:

Do not use this equipment if any faults or problems are detected.



Warning:

The user must schedule preventive maintenance by an approved Service Engineer.



Warning:

The user or a Service Engineer must correct problems before the system is used.



Warning:

Do not leave the patient unattended during the procedure.



Warning:

Keep the hands of the patient away from all buttons and switches at all times.



Caution:

To prevent damage or misalignment, be careful when you move the Affirm system.



Caution:

The Affirm Biopsy Guidance Module weighs 15 pounds. When you move it, be sure to have a secure grip on the handles.



Note

The system does not have any parts that are serviced by the user.

2.5 Compliance

This section describes the system compliance requirements and the responsibilities of the manufacturer.

2.5.1 Compliance Requirements

The manufacturer is responsible for the effects of safety, reliability, and performance of this equipment, with the following provisions:

- The equipment is used in accordance with the *User Guide*.
- Assembly operations, extensions, re-adjustments, modifications, or repairs are performed by authorized persons only.

2.6 Label Locations

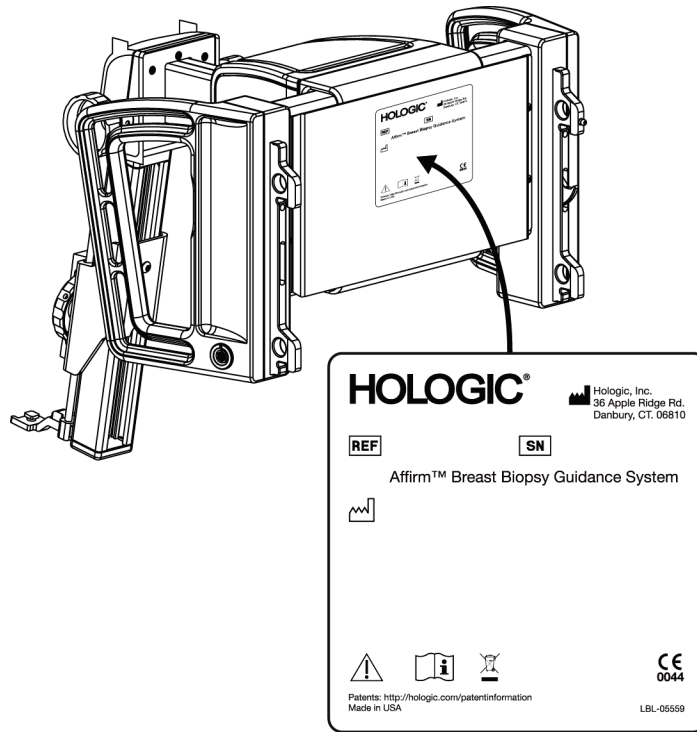

Figure 4: Biopsy Guidance Module Label Location

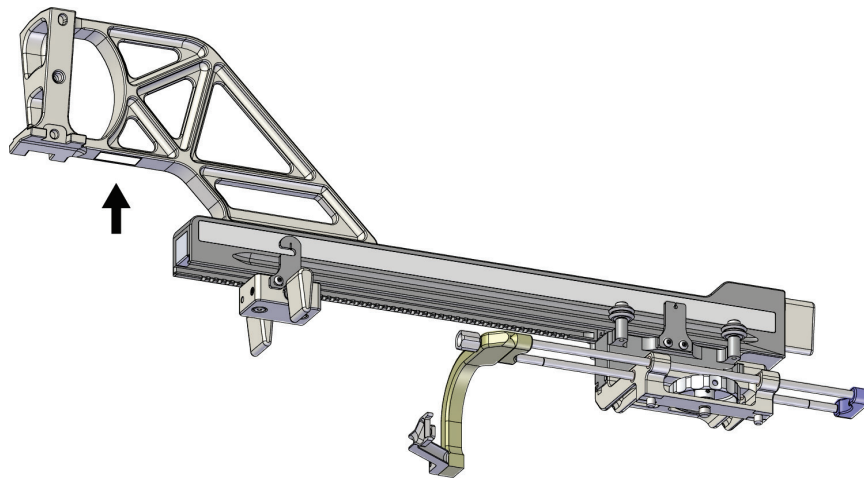

Figure 5: Lateral Arm Serial Number Label Location

Chapter 3 Installation, Verification, and Removal

3.1 Biopsy Guidance Module Components

The Biopsy Guidance Module installs on the front of the C-arm of the Selenia Dimensions and 3Dimensions systems. A lock lever (see the following figure, item 8) secures the module in position. A cable (item 7) connects to the side of the C-arm for operation of the biopsy guidance system.

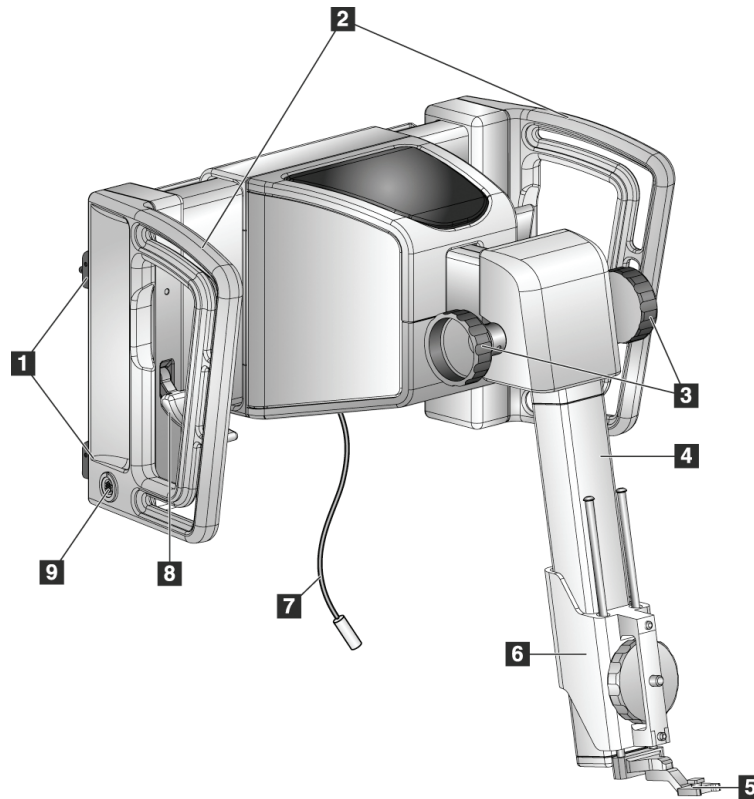

Figure 6: Biopsy Guidance Module

Affirm Breast Biopsy Guidance System User Guide

Chapter 3: Installation, Verification, and Removal

Table 1: Components of the Biopsy Guidance Module

#	Name	Description
1	Attachment Hooks	Two on each side hold the Biopsy Guidance Module on the imaging system Gantry.
2	Handles	One on each side. Hold both handles to lift the Biopsy Guidance Module.
3	Biopsy Device Advance/Retract Knobs	Rotate either knob to move the biopsy device along the slide rail.
4	Slide Rail	Holds the biopsy device mount and provides the track for manual biopsy device movements.
5	Needle Guide Holder	Holds the disposable needle guide through which the biopsy needle is inserted. (This front needle guide is removed when the Lateral Arm is installed.)
6	Device Mount	Holds the biopsy device adapter to which the biopsy needle is attached. Moves along the slide rail when a biopsy device advance/retract knob is rotated.
7	Cable	Connects to the imaging system to supply power to the Biopsy Guidance Module.
8	Lock Lever	One on each side. Engage the two levers to lock the Biopsy Guidance Module in position and onto the C-arm.
9	Receptacle	Accepts the cable from the Biopsy Control Module.

3.2 Biopsy Control Module Components

The Biopsy Control Module attaches to either the left or right handle on the Biopsy Guidance Module with a bracket (item 5). The display screen (item 2) is a touch screen for the user to perform the desired tasks. Motor Enable buttons (item 3) on either side of this module (and at the rear) activate motorized movement of the biopsy device.

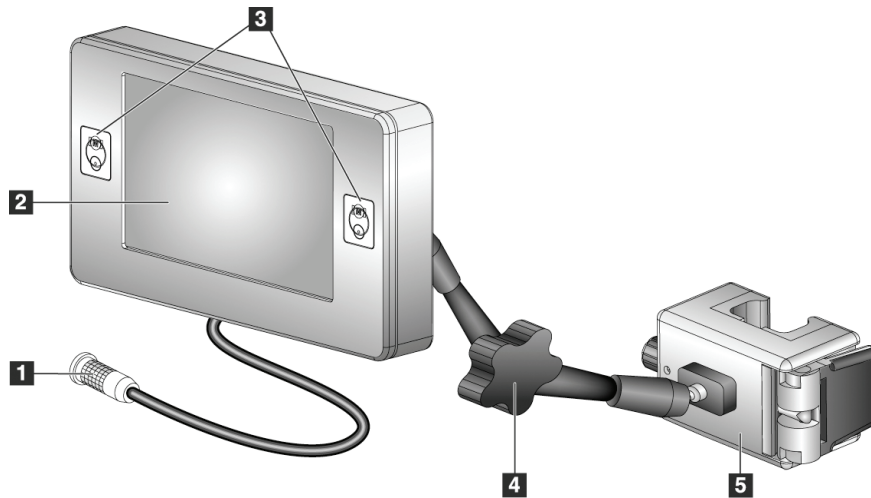

Figure 7: Biopsy Control Module

Table 2: Components of the Biopsy Control Module

#	Name	Description
1	Cable	Connects to the Biopsy Guidance Module.
2	Display Screen	Shows targets, system status, the name of the biopsy device, and safety margins. Touch screen buttons permit option selection.
3	Motor Enable Buttons	Front and back button pairs on either side of the display. Press the front and back buttons of either side at the same time to activate motor movement.
4	Articulating Arm Lock and Release	Rotate to release the lock and adjust the module. Rotate in the opposite direction to lock the arm and hold the module in the new position.
5	Attachment Bracket	Attaches to either handle of the Biopsy Guidance Module.

3.3 Installation of the Main Components

3.3.1 Attach the Biopsy Guidance Module

You can install the Biopsy Guidance Module with the imaging system power on or off.



Caution:

To prevent damage or alignment problems with the Needle Guidance Stage, be careful when you move the Biopsy Guidance Module.



Caution:

The Affirm Biopsy Guidance Module weighs 15 pounds. When you move it, be sure to have a secure grip on the handles.

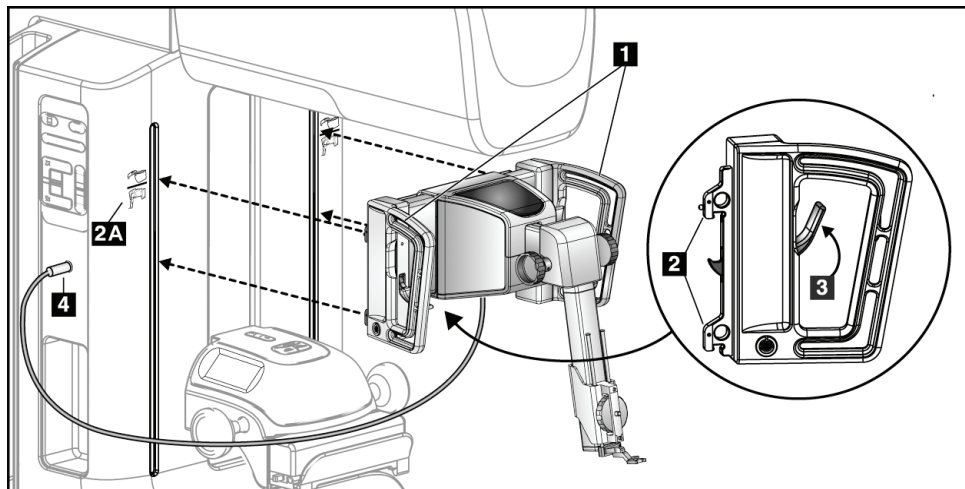

Figure 8: Installation of the Biopsy Guidance Module

1. Move the Compression Device down.
2. Hold the Biopsy Guidance Module by both handles.
3. Slide the top hooks (item 2) of the Biopsy Guidance Module into the slots marked with the Affirm system icon (item 2A) on the front of the imaging system C-arm. Make sure the top and bottom hooks attach to the C-arm.
4. Push the Lock Levers (item 3) on the Biopsy Guidance Module into the Up position to lock the Module against the C-arm.
5. Align the red dot on the Biopsy Guidance Module cable (item 4) with the red dot on the receptacle on the side of the C-arm. Connect the cable to the receptacle.

3.3.2 Attach the Biopsy Control Module

The Biopsy Control Module attaches to either the left or right handle of the Biopsy Guidance Module.

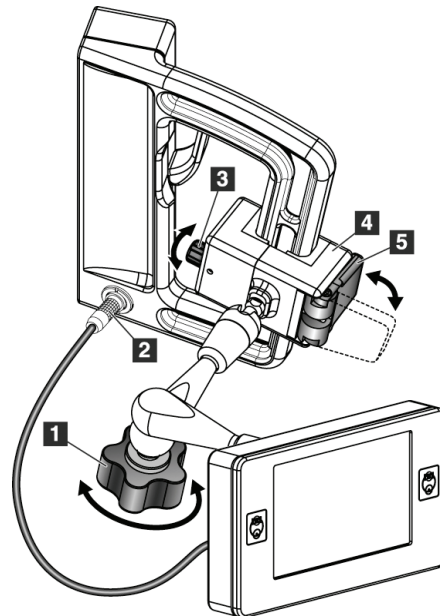

Figure Legend

1. Lock Knob for the Articulating Arm
2. Biopsy Control Module Cable
3. Clamp Adjust Knob
4. Attachment Bracket
5. Attachment Bracket Lock

Figure 9: Attachment of the Biopsy Control Module

1. Release the Articulating Arm Lock Knob (see the previous figure, item 1).
2. Position the Attachment Bracket (item 4) until the side with the Lock (item 5) is on the front side of the handle.
3. Attach the Lock side of the Attachment Bracket around the lower part of the handle.
4. Slide the opposite side of the Attachment Bracket around the handle. The Bracket attaches on to the patient handle.
5. If necessary, adjust the Clamp Adjust Knob (item 3).
6. Push the Attachment Bracket Lock to the locked position (item 5).
7. Make sure that this adjustment holds the bracket in position. If the bracket moves, or you cannot get the bracket lock fully into the locked position, adjust with the Clamp Adjust Knob (item 3).
8. Connect the Biopsy Control Module Cable (item 2) to the receptacle on the Biopsy Guidance Module.

Adjust the Bracket Height

1. Release the Attachment Bracket Lock (see the previous figure, item 5).
2. Slide the bracket to the required height.
3. Push the Attachment Bracket Lock into the locked position.

Adjust the Biopsy Control Module Position

1. Release the Lock Knob for the Articulating Arm (see the previous figure, item 1).
2. Tilt or change the current angle of the Biopsy Control Module.
3. Rotate the Lock Knob to lock the Biopsy Control Module in the new position.

3.4 Installation and Removal of Accessories

3.4.1 Biopsy Compression Paddles

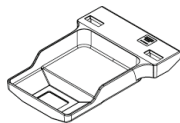

*5x5 cm Standard
Biopsy Paddle*

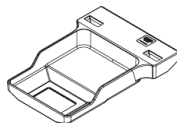

*6x7 cm Standard
Biopsy Paddle*

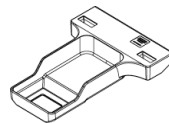

*5x5 cm Axillary
Biopsy Paddle*

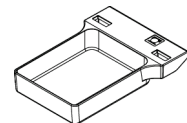

*15 cm Lateral Arm
Biopsy Paddle**

*The system automatically recognizes when a Lateral Arm is installed on the Biopsy Guidance Module.

The biopsy compression paddles attach to the compression device on the imaging system. Refer to the imaging system *User Guide* for instructions on installation and removal of the paddles.

3.4.2 Needle Guide



Warning:

Always use sterile techniques when you use Needle Guides during the patient procedures.



Warning:

It is important to install the device correctly. Be sure to insert the needle through the top and bottom Needle Guides.



Note

Your needle guides can look different from the needle guides shown.

Installation of the Needle Guide on the Standard Needle Guide Holder

1. Insert the needle guide rods of the needle guide holder into the standard device mount (slide in from the bottom).

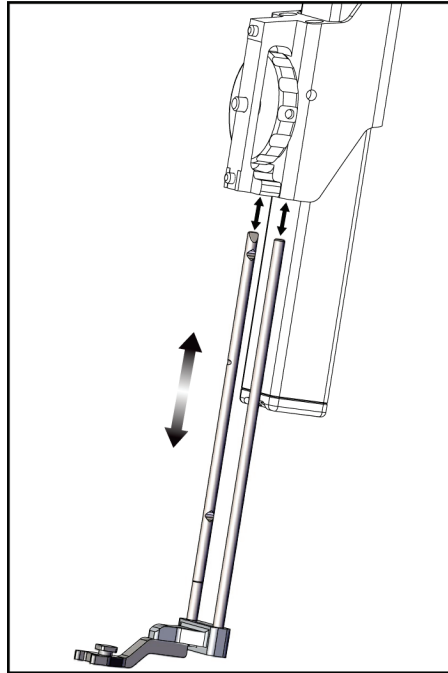

Figure 10: Installation of the Needle Guide Holder on the Standard Device Mount

2. Align the disposable needle guide (item 1) so that the raised-square side of the needle guide fits between the two lobes of the needle guide holder (item 2).

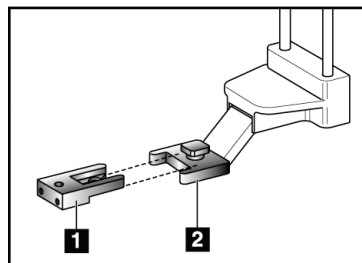

Figure 11: Installation of the Needle Guide on the Standard Needle Guide Holder

Figure Legend

1. Disposable Needle Guide
2. Needle Guide Holder (Standard)

3. Slide the open area of the U-shape in the needle guide around the pin in the needle guide holder.
4. Push the needle guide in until it locks into position.

Removal of the Disposable Needle Guide

1. Remove the biopsy device from the device mount.
2. Pull the disposable needle guide away from the pin on the needle guide holder.
3. Discard the disposable needle guide in accordance with local regulations.

3.4.3 Biopsy Device Adapter

Installation of the Biopsy Device Adapter on the Standard Device Mount

1. Align the outer holes in the biopsy device adapter (item 1 in the following figure) with the guide pins on the device mount.
2. Align the middle hole in the biopsy device adapter with the mount screw (item 2).
3. Turn the mount knob (item 3) to secure the biopsy device adapter.

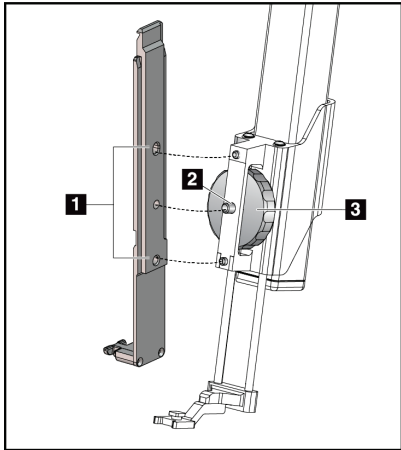

Figure Legend

1. Biopsy Device Adapter Holes
2. Device Mount Screw
3. Device Mount Knob

Figure 12: Attaching a Biopsy Device Adapter to the Device Mount (Standard)

Removal of the Biopsy Device Adapter

1. Turn the mount knob to release the biopsy device adapter.
2. Pull the biopsy device adapter away from the mount.

3.4.4 Biopsy Device

Follow the directions supplied by the manufacturer to install or remove the biopsy device and adapter. Carefully insert the biopsy needle through the disposable needle guide when installing the biopsy device.

3.4.5 Lateral Arm and Lateral Arm Accessories



Warning:

Be careful when working with the Lateral Arm. Bumping or jarring the Lateral Arm can affect system accuracy, cause patient injury, or cause equipment damage.

Lateral Arm Overview

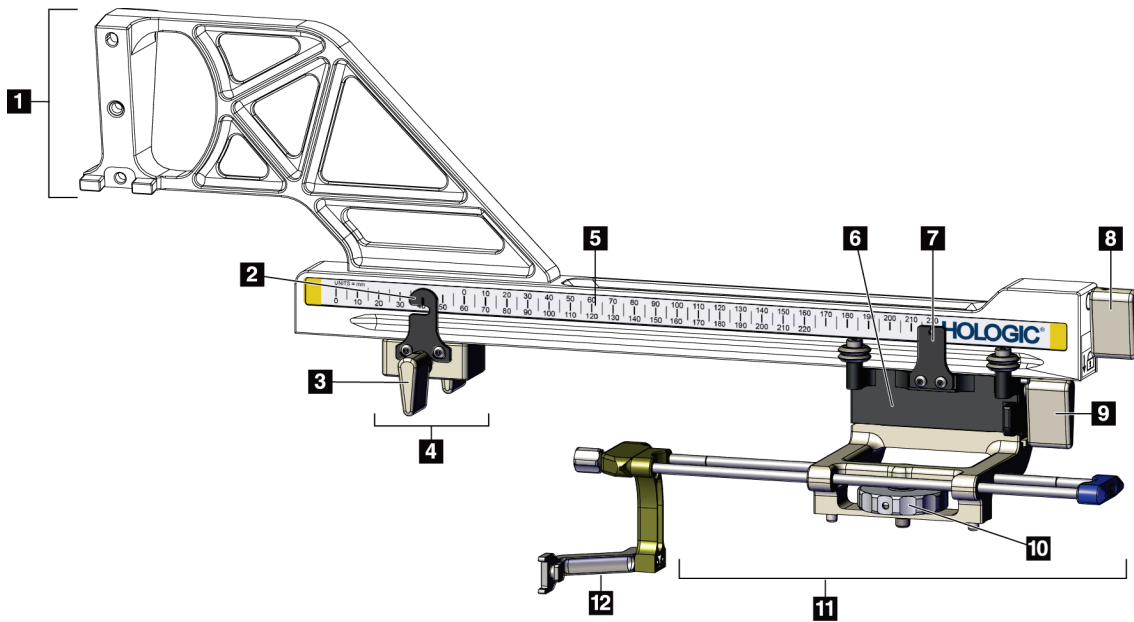

Figure 13: Lateral Arm Components

Affirm Breast Biopsy Guidance System User Guide

Chapter 3: Installation, Verification, and Removal

Table 3: Components of the Lateral Arm

#	Name	Description
1	Lateral Arm Mount	Mounting structure for the Lateral Arm. Attaches to the Standard Device Mount and holds the Lateral Arm on the Biopsy Guidance Module.
2	X-Stop Position Indicator	Shows the X-Stop position on the bottom scale on the Lateral Arm.
3	X-Stop Lever	Locking lever that locks and unlocks the X-Stop into position on the Lateral Arm.
4	X-Stop	Stops Carriage movement when locked into position. Set the X-axis Position Indicator at the Lat X coordinate on the lower scale to keep the biopsy device from traveling past the Lat X target. Push up while sliding the X-Stop along the Lateral Arm for smooth movement.
5	Scale	On each side of the Lateral Arm. Yellow scale is for right lateral needle approach. Blue scale is for left lateral needle approach. Use the top scale to position the carriage. Use the bottom scale to position the X-Stop.
6	Carriage	Attaches to the Lateral Arm and holds the device mount to which the biopsy needle is attached. Moves along the Lateral Arm during biopsy procedures.
7	Carriage Position Indicator	Shows the Carriage position on the upper scale on the Lateral Arm.
8	Carriage Lever	Engage the lever to lock the Carriage into position on the Lateral Arm rail. Locked = vertical down position. Unlocked = vertical up position. Set the lever to the full unlocked position for smooth movement along the Lateral Arm.
9	Device Mount Lever	Locking lever that locks and unlocks the device mount onto the carriage.
10	Device Mount Knob	Rotate the knob to attach and detach the biopsy device adapter.
11	Device Mount	Holds the biopsy device adapter to which the biopsy needle is attached. The needle guide holder attaches to the end of the needle guide rods on the device mount.
12	Needle Guide Holder	Holds the disposable needle guide through which the biopsy needle is inserted.

The Lateral Arm can be mounted to the left or the right side of the Biopsy Guidance Module to permit a lateral needle approach from either direction. Determine the desired approach before mounting the Lateral Arm and install the Biopsy Control Module on the opposite side from the desired approach.

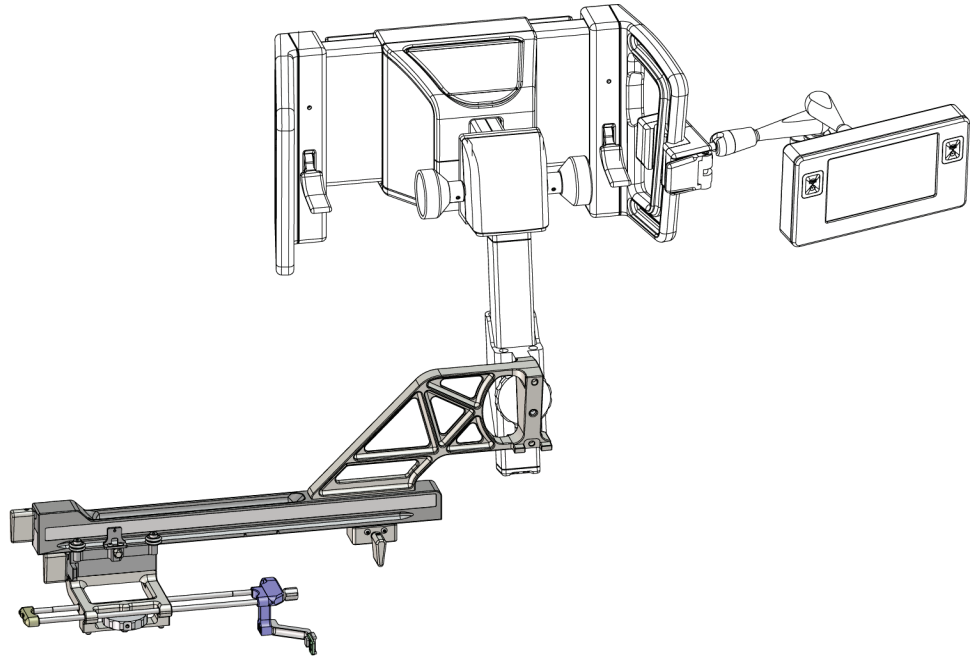

Figure 14: Left Needle Approach of Lateral Arm (Blue)

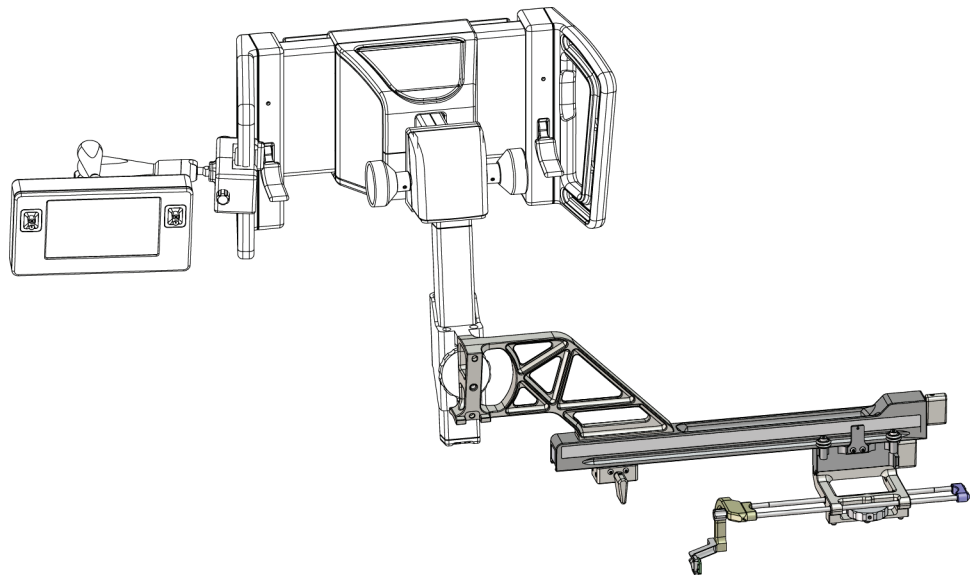

Figure 15: Right Needle Approach of Lateral Arm (Yellow)

Lateral Arm



Warning:

Clean the Lateral Arm before and after every use (refer to [For General Cleaning](#) on page 82).

Installation of the Lateral Arm

1. Make sure that the C-arm is set to 0 degrees.
 2. Place the Lateral Arm Stand tightly over the image receptor.
-



Note

Use the Lateral Arm Stand *only* for Lateral Arm procedures.

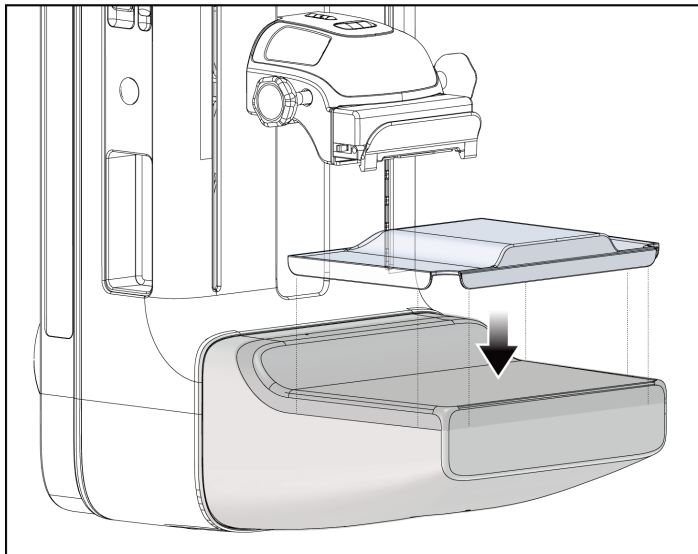

Figure 16: Installing the Lateral Arm Stand over the Image Receptor

3. Install the Lateral Arm Biopsy Paddle. After the paddle is installed, the system automatically recognizes that a Lateral Arm is being used on the Biopsy Guidance Module. If the C-arm is not set to 0 degrees, the Biopsy Control Module prompts you to rotate the C-arm to 0 degrees.

4. On the Affirm system, remove the needle guide holder used on the standard device mount.

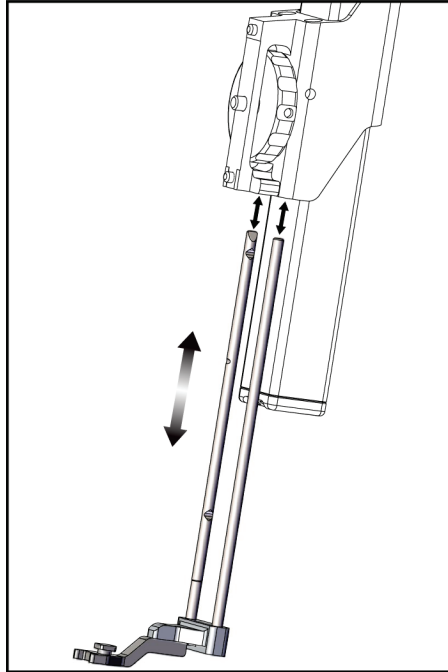

Figure 17: Removing the Needle Guide Holder from the Standard Device Mount

5. Determine the direction of approach of the biopsy device (left or right side of the Biopsy Guidance Module). Make sure that the Biopsy Control Module is attached to the correct side of the Biopsy Guidance Module for the desired needle approach.

Affirm Breast Biopsy Guidance System User Guide

Chapter 3: Installation, Verification, and Removal

6. Attach the Lateral Arm to the Biopsy Guidance Module (see the following figure).
 - a. Align the top and bottom guide holes on the Lateral Arm (item 1 in the following figure) to the top and bottom pins on the device mount on the Biopsy Guidance Module.
 - b. Align the center hole of the Lateral Arm (item 2) with the mount screw on the device mount.
 - c. Turn the mount knob (item 3) to secure the Lateral Arm to the Biopsy Guidance Module.
 - d. Make sure that the two mounting surfaces are aligned correctly.

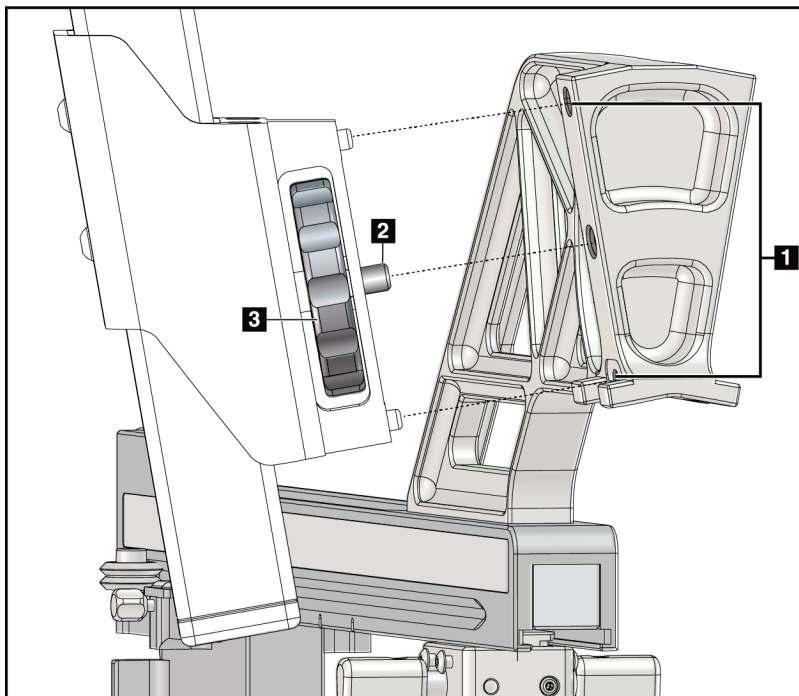

Figure Legend

1. Lateral Arm Mount Guide Holes
2. Device Mount Screw
3. Device Mount Knob

Figure 18: Installing the Lateral Arm on the Device Mount

7. On the Biopsy Control Module, select the correct **Lateral Arm Mounting Side** button for the side the Lateral Arm is mounted on.



Figure 19: Selection Screen for the Lateral Arm Mounting Side

8. On the Biopsy Control Module, select **OK** to confirm that the Lateral Arm Stand is installed.

Removal of the Lateral Arm

1. On the standard device mount, turn the device mount knob to loosen the device mount screw.
2. Pull the Lateral Arm away from the Biopsy Guidance Module.
3. Remove the Lateral Arm Paddle.
4. Remove the Lateral Arm Stand.

Needle Guide for the Lateral Arm



Warning:

Always use sterile techniques when you use Needle Guides during the patient procedures.



Warning:

It is important to install the device correctly. Be sure to insert the needle through the top and bottom Needle Guides.



Note

The needle guides can look different from the needle guides shown.

Installation of the Needle Guide on the Lateral Arm Needle Guide Holder

1. Make sure that the Lateral Arm is attached to the correct side of the Biopsy Guidance Module for the desired direction of approach. If necessary, see the figures [Left \(and Right\) Approach of Lateral Arm](#) on page 23.
2. Make sure that the device mount is installed on the correct side of the Lateral Arm for the desired direction of approach. If necessary, refer to [Device Mount for the Lateral Arm](#) on page 30.
3. Make sure that the correct needle guide holder is installed on the needle guide rods based on the needle approach (see the following set of figures). If necessary, remove the existing needle guide holder (item 1) and install the correct one (item 2). Keep in mind the following:
 - The blue end of the needle guide rods receives the blue needle guide holder for the left approach.
 - The yellow end of the needle guide rods receives the yellow needle guide holder for the right approach.

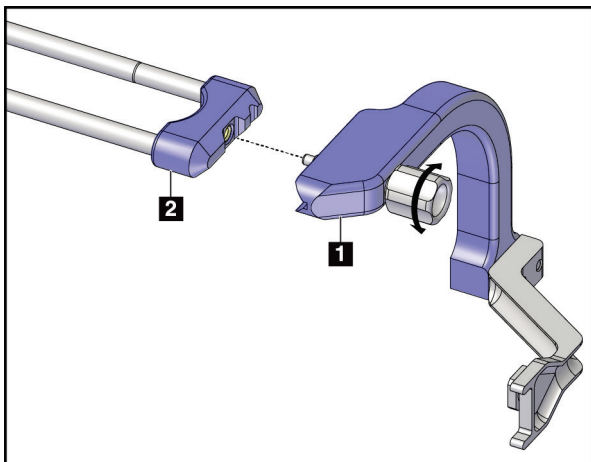

Figure 20: Attaching the Blue Needle Guide Holder to the Needle Guide Rods (Left Needle Approach)

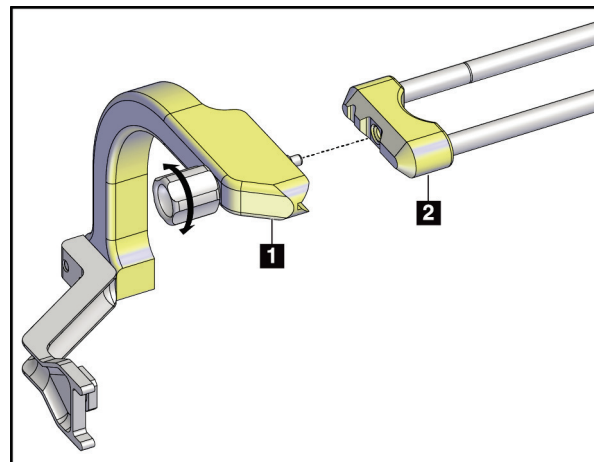

Figure 21: Attaching the Yellow Needle Guide Holder to the Needle Guide Rods (Right Needle Approach)

4. Slide the disposable needle guide (item 1) over the pin on the end of the needle guide holder (item 2).

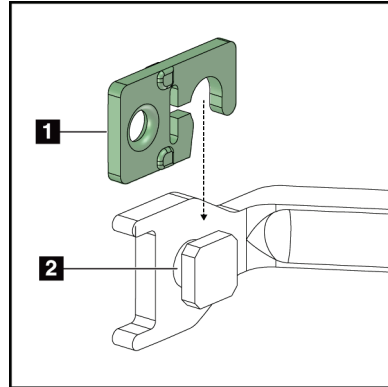

Figure Legend

1. Disposable Needle Guide
2. Needle Guide Holder

Figure 22: Installing a Disposable Needle Guide on a Needle Guide Holder (Lateral Arm)

Removal of the disposable Needle Guide

1. Remove the biopsy device and adapter from the device mount.
2. Pull the disposable needle guide away from the pin on the needle guide holder.
3. Discard the disposable needle guide in accordance with local regulations.

Device Mount for the Lateral Arm

Installation of the Device Mount

1. Flip the Carriage lever completely up to the unlocked position.

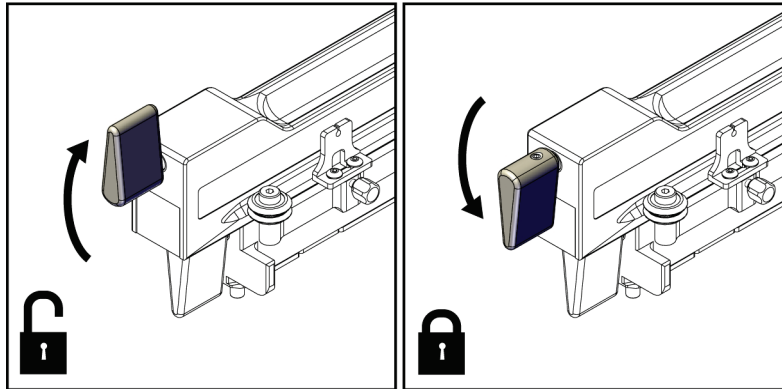

Figure 23: Carriage Lever Locked and Unlocked Positions



Note

The Carriage lever must be fully in the up position for smooth movement along the Lateral Arm.

2. Using the Carriage Position Indicator and the upper scale, set the Carriage position to 220 mm.



Note

Setting the Carriage Position Indicator at 220 mm provides a safe distance from the breast to attach the biopsy device.

3. Flip the Carriage lever completely down to the locked position.
4. Flip the device mount lever up to the unlocked position.

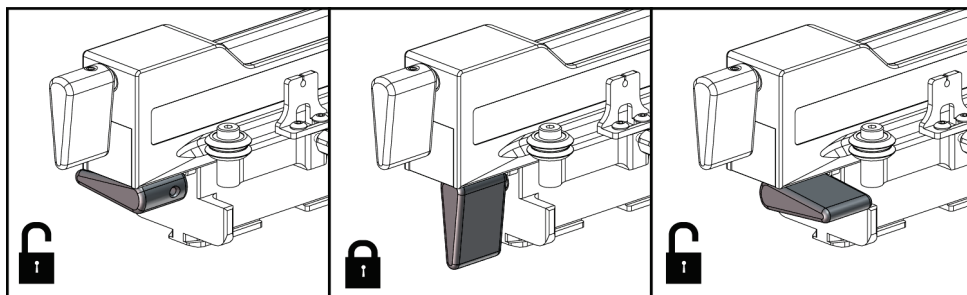

Figure 24: Locked and Unlocked Positions of Device Mount Lever

5. Slide the device mount onto the Lateral Arm Carriage until it stops.

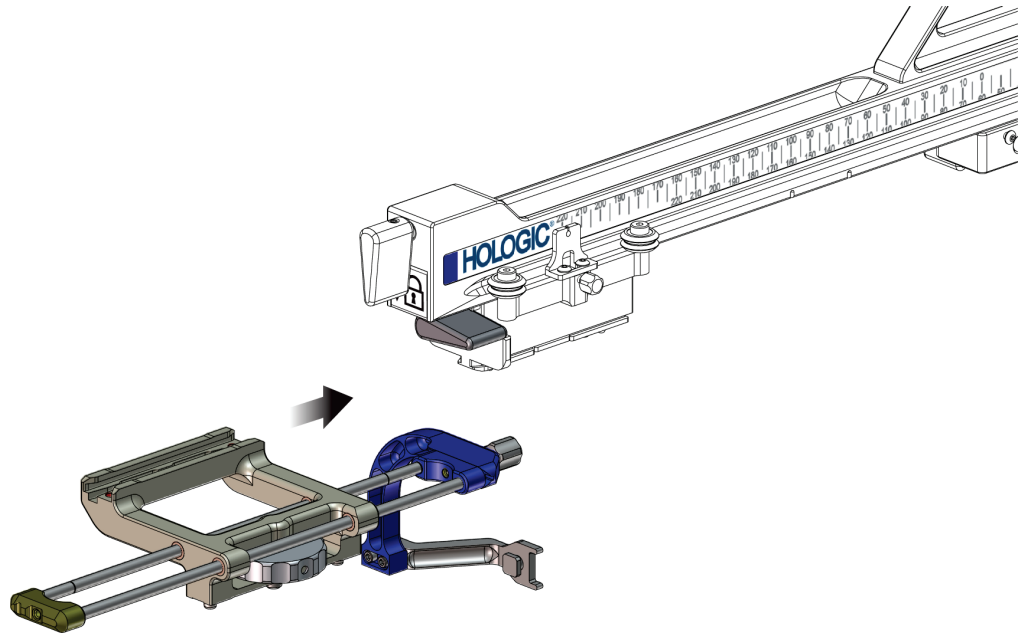

Figure 25: Installing Device Mount onto Lateral Arm Carriage



Note

The device mount must be installed with the needle guide in front of the Lateral Arm.

6. Flip the device mount lever down to lock the device mount in position.

Removal of the Device Mount

1. Flip the device mount lever up to unlock the device mount.
2. Slide the device mount off the Lateral Arm.

Biopsy Device Adapter

Installation of the Biopsy Device Adapter

1. Align the outer holes in the biopsy device adapter (item 1 in the following figure) with the guide pins on the device mount.
2. Align the center hole in the biopsy device adapter with the mount screw (item 2).
3. Turn the device mount knob (item 3) to secure the biopsy device adapter.

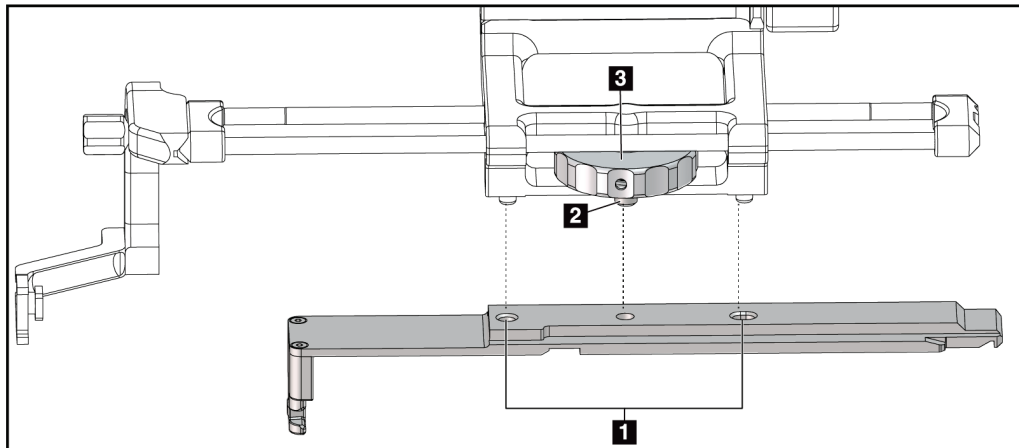

Figure 26: Attaching the Biopsy Device Adapter to the Device Mount (Lateral Arm)

Figure Legend

1. Biopsy Device Adapter Holes
2. Device Mount Screw
3. Device Mount Knob

Removal of the Biopsy Device Adapter

1. Turn the mount knob to release the biopsy device adapter.
2. Pull the biopsy device adapter away from the device mount.

Biopsy Device

Follow the directions supplied by the manufacturer to install or remove the biopsy device and adapter. Carefully insert the biopsy needle through the disposable needle guide when installing the biopsy device.

Biopsy Device Precautions with the Lateral Arm



Warning:

Make sure that the carriage lever, device mount lever, and X-Stop lever are fully locked before firing the biopsy device or acquiring tissue samples.

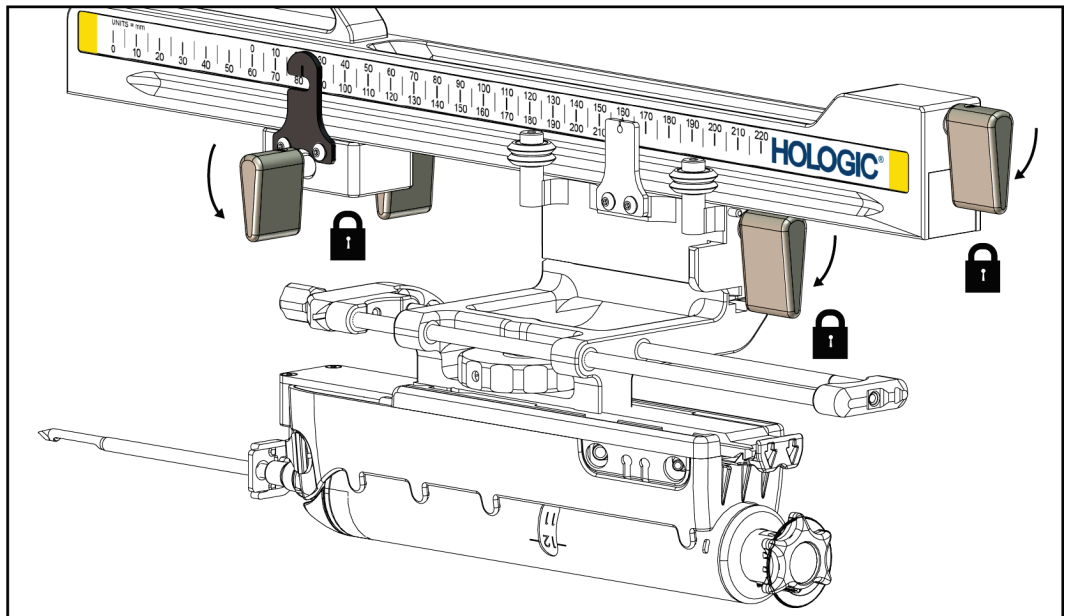

Figure 27: Lock Levers in Fully Locked Position

X-Stop

The X-Stop is an accessory that stops movement of the Carriage and the device mount along the Lat X axis. The X-Stop Position Indicator is used to position the X-Stop along the bottom scale of the Lateral Arm. During a procedure, the X-Stop is positioned at the Lat X coordinate as shown on the Biopsy Control Module. When the X-Stop is locked in place and the Carriage is positioned against the X-Stop, the X-Stop position and the Carriage position are at the same value on their respective scales. Use of the X-Stop is optional.

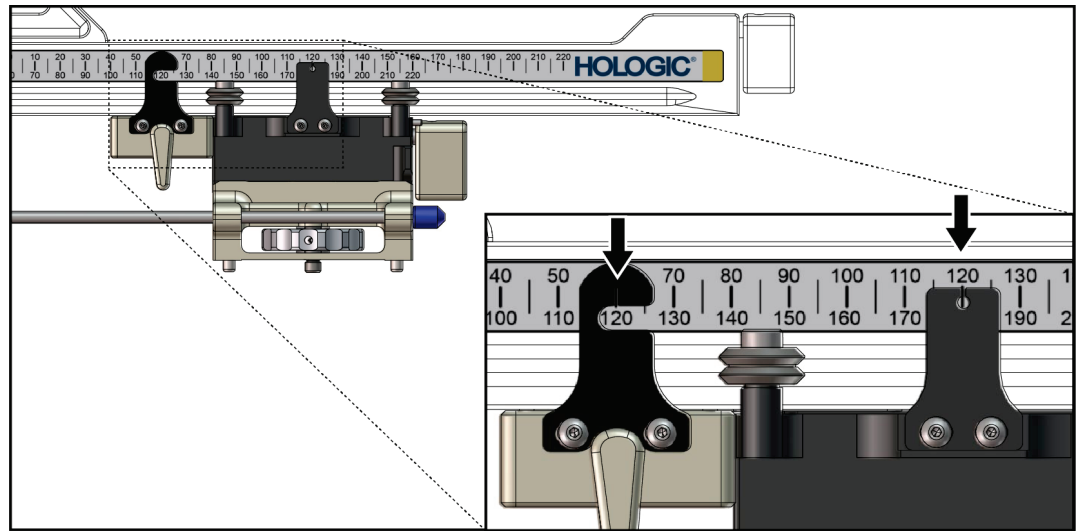

Figure 28: Scales and Positioning for the X-Stop and Carriage

Installation of the X-Stop

1. Make sure that the X-Stop lever is fully in the unlocked (up) position.
2. Slide the X-Stop onto the Lateral Arm on the same side as the Lateral Arm mount. The X-Stop only slides on when the open side of the X-Stop Position Indicator is turned toward the Lateral Arm Mount. See the following figure for positioning.

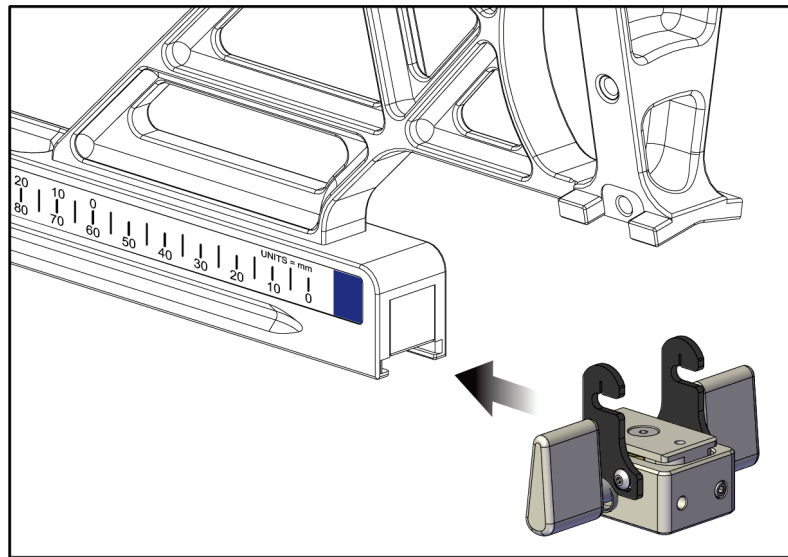

Figure 29: Installing the X-Stop on the Lateral Arm

3. Set the X-Stop Position Indicator to the desired position on the scale.



Note

For smooth movement, push up when sliding the X-Stop into position.

4. Flip the X-Stop lever down into the locked position.



Warning:

The X-Stop must be in the locked position before the biopsy device is moved into position.

Removal of the X-Stop

1. Flip the X-Stop lever fully up into the unlocked position.
2. Slide the X-Stop off the Lateral Arm.
3. Flip the X-Stop lever into the unlocked (down) position for storage.



Note

The X-Stop is stored in the locked position in the Lateral Arm case.

3.5 System Verifications

3.5.1 Confirm the Host Connection

When the imaging system is On and the Affirm system cable connections are correct, the *Home* screen shows on the Biopsy Control Module.

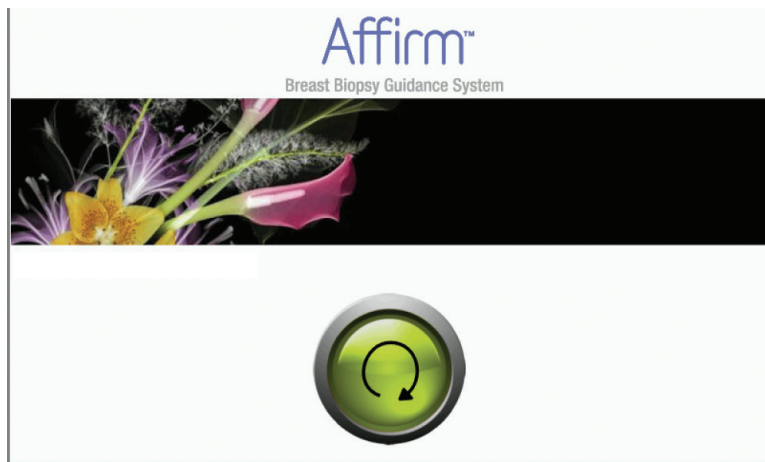

Figure 30: Home Screen on the Biopsy Control Module

3.6 Removal of the Main Components

3.6.1 Biopsy Control Module

To remove the Biopsy Control Module from the Biopsy Guidance Module:

1. Disconnect the cable of the Biopsy Control Module from the Biopsy Guidance Module.
2. Release the bracket lock.
3. Remove the Biopsy Control Module from the Biopsy Guidance Module.
4. Store the Biopsy Control Module in a protected location.

3.6.2 Biopsy Guidance Module



Caution:

To prevent damage or alignment problems with the Needle Guidance Stage, be careful when you move the Biopsy Guidance Module.



Caution:

The Affirm Biopsy Guidance Module weighs 15 pounds. When you move it, be sure to have a secure grip on the handles.

To remove the Biopsy Guidance Module from the imaging system C-arm:

1. Disconnect the Biopsy Guidance Module Cable from the C-arm.
2. Hold a handle of the Biopsy Guidance Module with one hand while you release the Locking Levers with the other hand.
3. Put a hand on each handle and lift the Biopsy Guidance Module from the slots in the C-arm.
4. Store the Biopsy Guidance Module and Biopsy Control Module in a safe location. Make sure that you put the unit on its back (hooks down).

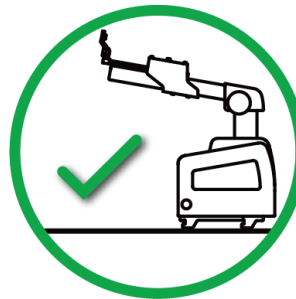

3.7 Tabletop Stand for the Affirm System



Caution:

The Affirm system Tabletop Stand is not for mobile applications.

To place the Affirm biopsy system on the optional stand, see the following figure.

1. Move the device mount and needle guide to the highest upper position as shown in **A**.
 2. Disconnect the biopsy guidance module cable from the imaging system C-arm.
 3. Remove the Affirm Biopsy Guidance Module along with the Biopsy Control Module, if present, from the imaging system.
-



Caution:

To prevent damage or alignment problems with the Needle Guidance Stage, be careful when you move the Biopsy Guidance Module.



Caution:

The Affirm Biopsy Guidance Module weighs 15 pounds. When you move it, be sure to have a secure grip on the handles.

4. Place the Affirm system on the Tabletop Stand as shown in **B**.

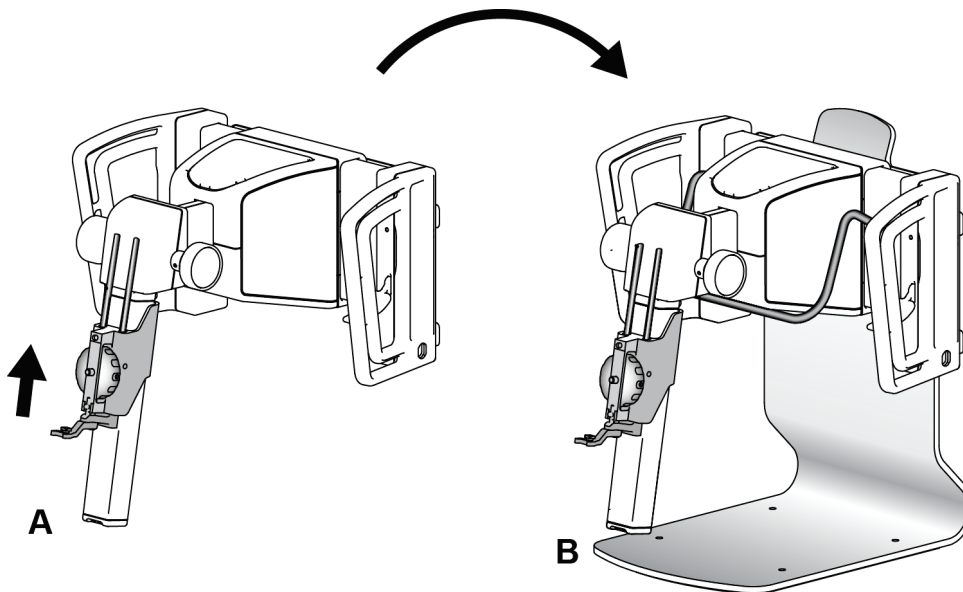

Figure 31: Affirm System Tabletop Stand

3.8 Storage Case for the Lateral Arm

The Lateral Arm is supplied with a storage case to safely store all the Lateral Arm components. The Lateral Arm QAS Phantom is also stored in the storage case. To protect the equipment and to maintain accuracy, always store the Lateral Arm and its components in its case.



Figure 32: Lateral Arm and Storage Case

Chapter 4 User Interface - Biopsy Control Module

4.1 Biopsy Control Module Screens

4.1.1 Home Screen

The *Home* screen shows the name or initials of the user who logs in and any error messages. The **Go** button takes the user to the *Target Guidance* screen.

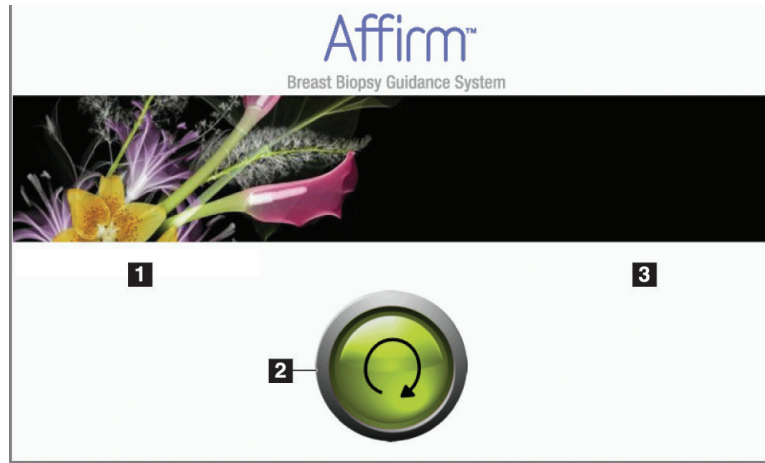

Figure 33: Home Screen

Figure Legend

1. User ID Area
2. **Go to Target Guidance** Button
3. Error Message Area

4.1.2 Target Guidance Screen

The following figure shows the main screen of the Biopsy Control Module. This screen shows the current position of the biopsy device, the selected target coordinates and the Cartesian difference between the two positions.

The buttons in the *Target Guidance* screen allow the user to go to the previous screen (item 3), go to the screen for target selection (item 2), go to the screen for motorized movement of the biopsy device in the X and Y axes (item 1), select the C-Arm Mode or Stereo Mode for the C-arm rotation (item 5), and cancel an audible signal (item 7).

The display area (item 4) of the *Target Guidance* screen shows the difference between the current position of the biopsy device and the target coordinates, the status of the system (item 10), the biopsy device installed on the system (item 8), and the safety margins (item 9).

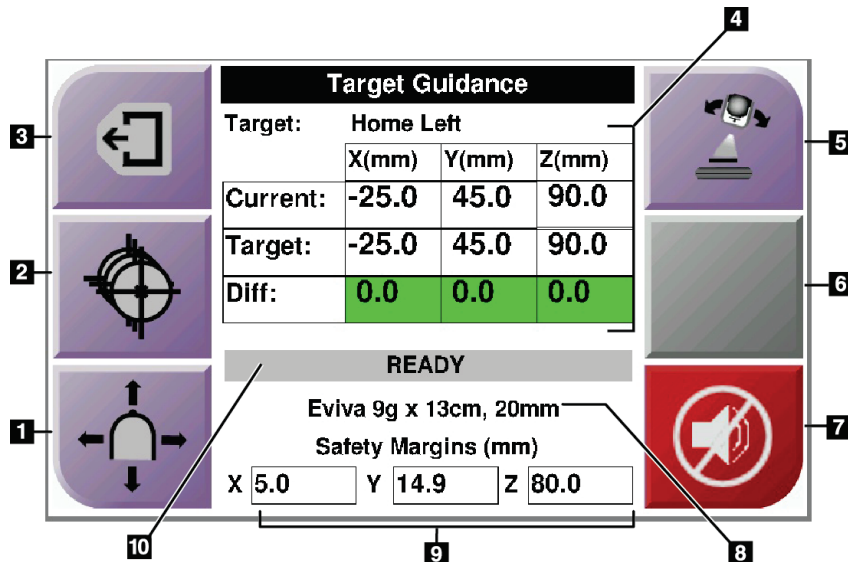

Figure 34: Target Guidance Screen

Figure Legend

1. Go to the *Jog Mode* screen
2. Go to the *Select Target* screen
3. Go to the previous screen
4. Target Information
5. Switch between C-Arm Mode or Stereo Mode (when the system is set for Manual C-Arm Stereo Mode).
6. This button is gray and disabled.
7. Mute or Enable Sound (An icon displays on this button and an alarm sounds when there is a system fault. Refer to [The Sound Button](#) on page 45.)
8. Selected Biopsy Device
9. Safety Margins
10. System Status



Note

The X, Y, and Z cells in the screen can change color as target coordinates change. Refer to [Colored Cells in the Screens](#) on page 44.

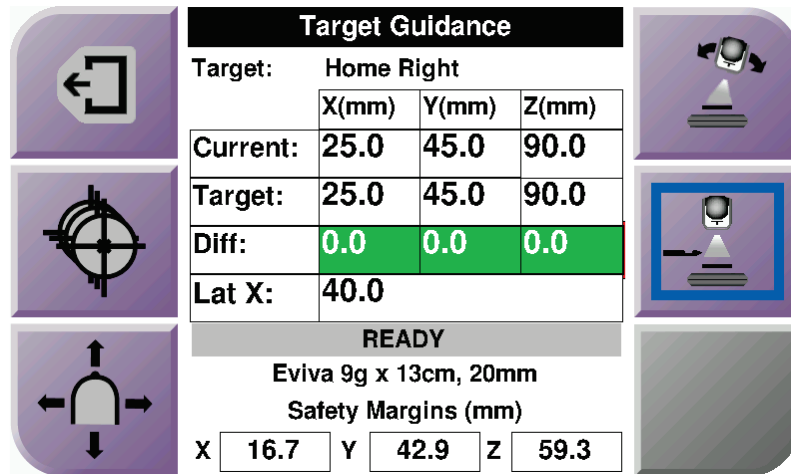

Figure 35: Target Guidance Screen for Lateral Arm

When the Lateral Arm is installed, the *Target Guidance* screen includes a field for the Lat X value.

The disabled gray button on the right side of the screen is now the **Lateral Arm Mounting Side** button (item 6 in the previous figure). The **Lateral Arm Mounting Side** button on the right side of the screen shows the side of approach for the biopsy. Press the **Lateral Arm Mounting Side** button to return to the *Confirmation* screen for the Lateral Arm Mounting Side.

Colored Cells in the Screens

Green Cells

When all Diff cells are green, the biopsy device is in the correct position for the selected target. When the biopsy device is fired, the target is at the center of the aperture of the device.

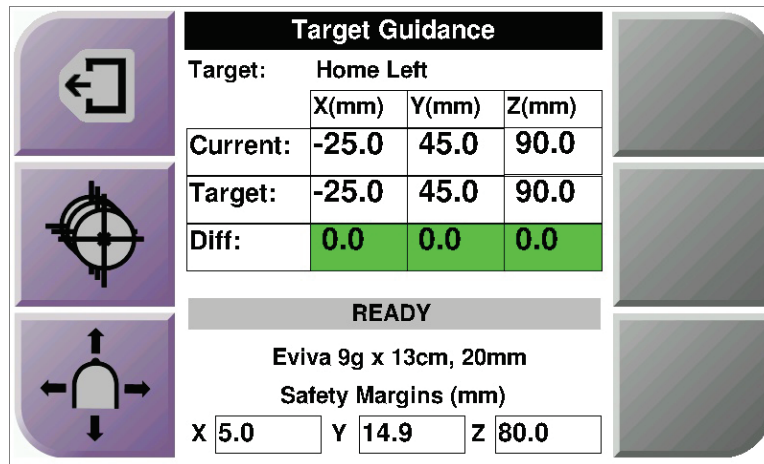

Figure 36: Green Differential Cells

Yellow and Red Cells

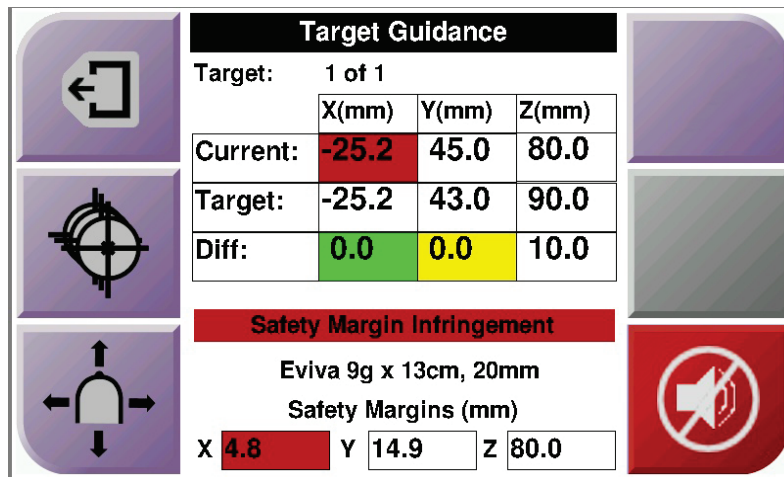



Figure 37: Yellow and Red Cells

- **Yellow** indicates that the biopsy device is in the correct position for that axis, but you must move the device to the final Z-position. When the biopsy device is in the final Z-position, the yellow cell changes to green.
- **Red** indicates a problem with a safety margin. The **Sound** button appears and the system makes repeated beeps. Make adjustment in the axis indicated by red. When the cell is not red, the device is within the safety limits.

The Sound Button

The **Sound** button is enabled when there is a system fault. When the **Sound** button displays, you can control system sounds related to alarms and motor movements of the biopsy device.

*Table 4: How to Use the **Sound** Button*

Sound	
 <p><i>Figure 38: Alert Sounds Are Audible</i></p>	<ul style="list-style-type: none"> • When a safety margin is violated, this mute icon shows and the system repeats a beep sound. • To stop the beep sounds, press the Sound button. All system beep sounds are muted, and the icon on the button changes. • When you correct the safety margin violation, the icon on the button disappears. • If you press the button and do not correct the system fault within two minutes, the system beep sounds are enabled automatically.
 <p><i>Figure 39: Alert Sounds Are Muted</i></p>	<ul style="list-style-type: none"> • When this icon appears on the Sound button, you have the option to enable the system beep sounds. • To enable the system beep sounds, press this button. • If you do not press this button, system beep sounds are enabled automatically within two minutes after this icon displays.

4.1.3 Jog Mode Screen

This screen allows the user to manually overwrite the targeting coordinates of the Biopsy Guidance Module. The arrow buttons in the *Jog Mode* screen change the Jog value of the X and Y coordinates. Other buttons in this screen allow the user to go to the *Target Guidance* Screen (item 5), and cancel (item 7) an audible signal that sounds when there is a problem with a safety margin.

The display area (item 4) of the *Jog Mode* screen shows the difference between the current position of the biopsy device and the target coordinates, the status of the system (item 10), the biopsy device installed on the system (item 8), and the safety margins (item 9).



Warning:

Red cells indicate a problem with a safety margin. Patient injury or equipment damage may occur if you continue. Make adjustments to be within safety limits.

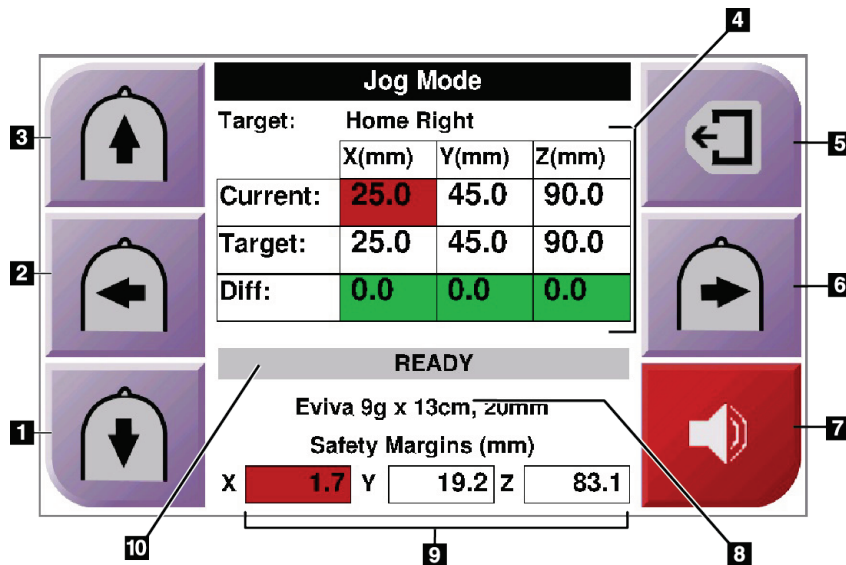

Figure 40: Jog Mode Screen

Figure Legend

1. Change Y-axis Jog value in negative direction
2. Change X-axis Jog value in negative direction
3. Change Y-axis Jog value in positive direction
4. Target Information
5. Go to the previous screen
6. Change X-axis Jog value in positive direction
7. Mute or Enable Sound (An icon displays on this button and an alarm sounds when there is a problem. Refer to [The Sound Button](#) on page 45 for more information about the Sound button.)
8. Selected Biopsy Device
9. Safety Margins
10. System Status

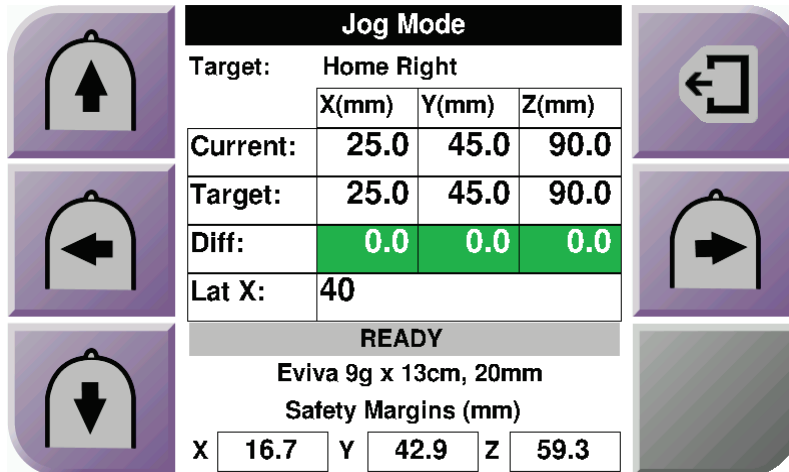

Figure 41: Jog Mode Screen for Lateral Arm

When the Lateral Arm is installed, the *Jog Mode* screen includes a field for the Lat X value.

4.1.4 Select Target Screen

This screen allows the user to select a different target for biopsy guidance or to move to one of the Home positions. The buttons in the *Select Target* screen allow the user to go to the previous screen (item 1), go to the *Target* screen (item 2), or go to the Left or Right Home Position (item 3 or item 6).

The display area (item 4) of the *Select Target* screen shows one of more sets of target coordinates. The name of the biopsy device that was selected also displays (item 5).

To move the biopsy device to one of the targets shown in this screen:

1. Press one of the target coordinates icons or the **Home** buttons.
The system changes to the *Target Guidance* screen.
2. Press and hold a right or left **Motor Enable** button pair on the Biopsy Control Module. The needle moves to the X and Y positions.

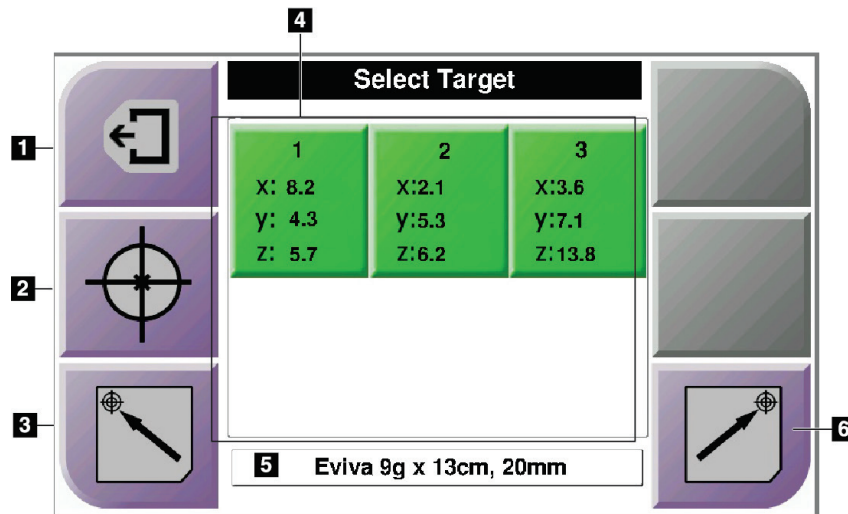

Figure 42: Select Target Screen

Figure Legend

1. Go to the previous screen
2. Go to the *Target Guidance* screen
3. Go to the Home Left Position
4. Target Coordinates
5. Biopsy Device
6. Go to the Home Right Position



Note

You must simultaneously press both switches of a right or left **Motor Enable** pair to start the motor movement.

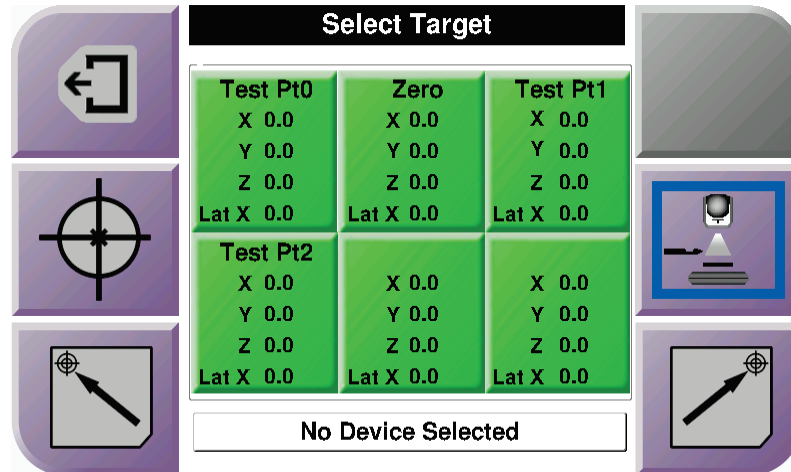

Figure 43: Select Target Screen for Lateral Arm

When the Lateral Arm is installed, the target coordinate icons on the *Select Target* screen include a line for the Lat X value.

The **Lateral Arm Mounting Side** button on the right side of the screen shows the side of the needle approach for the biopsy. Press the **Lateral Arm Mounting Side** button to return to the *Confirmation* screen for the Lateral Arm Mounting Side.

Chapter 5 Biopsy

5.1 Biopsy Views

When performing a 2D biopsy procedure, the biopsy guidance system requires stereo views. Stereo views are images taken at $+15^\circ$ and -15° angles. Collectively, these two images are called a stereo pair. The word "stereo" in the biopsy procedures refers to the $+15^\circ$ and -15° projections. The stereo pair images are used to determine the three-dimensional (X-Y-Z) Cartesian coordinates of the region of interest.

When performing a 3D™ biopsy procedure, the biopsy guidance system requires a tomosynthesis image set. The tomosynthesis slice is used to determine the three-dimensional (X-Y-Z) Cartesian coordinates of the region of interest.

5.1.1 Add a Biopsy View

To Add a Biopsy View:

1. In the *Procedure* screen, select the **Add View** button to display the *Add View* screen.

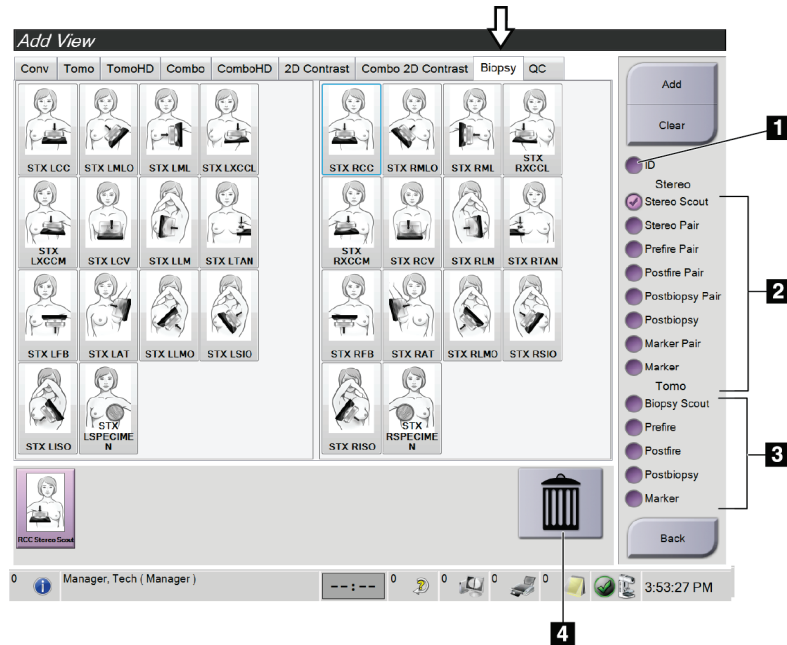

Figure 44: Biopsy Tab in the Add View Screen

Figure Legend

1. Implant Displaced
2. Stereo View Modifiers
3. Tomosynthesis View Modifiers
4. Trash Can Icon

2. Select the **Biopsy** tab.
3. Select the view, then select a View Modifier from the right panel of the screen.



Note

The Biopsy Stereo and Tomosynthesis View Modifiers show only when the system has licenses for tomosynthesis and biopsy.

4. Select the **Add** button. A thumbnail image for each view that you select appears in the bottom of the screen.

To Remove a Biopsy View:

- To remove a single view from the added list: in the bottom panel of the screen, select the view thumbnail then select the **Trash Can** icon.
- To remove all views from the added list: select the **Clear** button.

Add a Stereo Biopsy Half-Pair View

You can add a view to acquire a single -15° or $+15^{\circ}$ Stereotactic 2D biopsy image. This view allows you to create a target using the Stereotactic Scout and the single Stereotactic 2D view.

1. In the *Procedure* screen, select the **Add View** button to display the *Add View* screen.
2. Select the **Biopsy** tab.
3. Select the Stereotactic 2D view, then select the Stereo (-) or the Stereo (+) view modifier from the right panel of the screen.

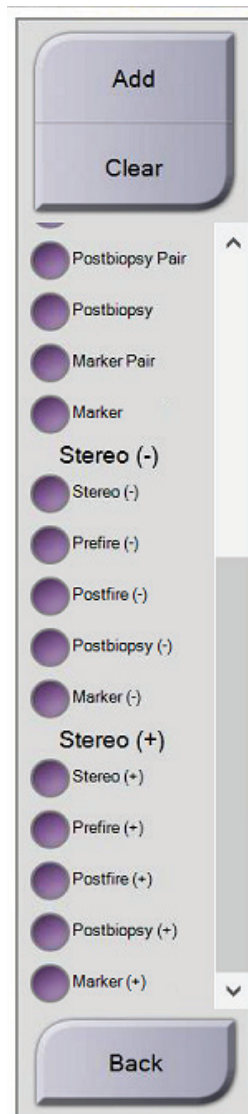

Figure 45: Stereo (-) and Stereo (+) View Modifiers

4. Select the **Add** button. A thumbnail image for the view that you select appears on the bottom of the screen.

5.1.2 Edit a Biopsy View

Use the *Edit View* screen to assign a different view to an image.

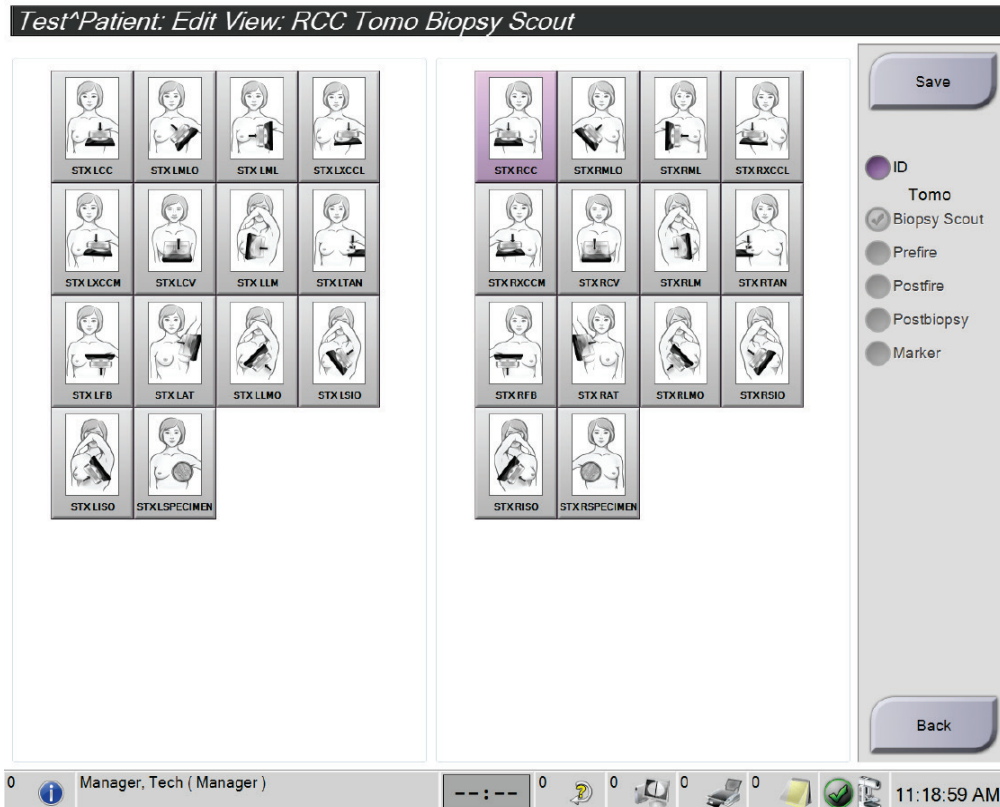

Figure 46: Edit (Biopsy) View Screen

To Edit a View:

1. In the *Procedure* screen, select an exposed thumbnail image view.
2. Select the **Edit View** button to access the *Edit View* screen.
3. Select the view, then select the View Modifiers from the right side of the screen.
4. Select the **Save** button.
5. When the *Update Successful* dialog box appears, select the **OK** button.

5.2 C-Arm Stereo Modes

Acquire the stereo images in either the Auto C-arm Stereo Mode or the Manual C-arm Stereo Mode. Make the C-arm Stereo Mode selection at the Acquisition Workstation (refer to [How to Select the C-Arm Stereo Mode for Image Acquisition](#) on page 57).

5.2.1 C-Arm Rotation in the C-Arm Stereo Modes

The mechanics of C-arm rotation for stereotactic image acquisition is different in Auto and Manual C-arm Stereo Modes.

**Note**

C-arm vertical movement and rotation are disabled when compression force is applied. A service engineer can configure the lockout force from 22 Newtons (5 pounds) to 45 Newtons (10 pounds).

In Auto C-Arm Stereo Mode

In the Auto C-arm Stereo Mode, the *Target Guidance* screen does not show the **C-arm Stereo Mode** button. In the Auto C-arm Stereo mode, the system automatically lets the C-arm move separately from the Tube Arm to acquire the stereo images. When the **X-ray** button is pressed to start stereo image acquisition, the Tube Arm automatically moves to the first 15° angle, acquires the image, rotates to the opposite 15° angle and acquires that image.

**Note**

The option to position the Tube Arm for the first stereo image is in the System Status menu (refer to [How to Select the C-Arm Stereo Mode for Image Acquisition](#) on page 57). The Tube Arm automatically rotates to the selected 15° angle. This option operates in both C-arm Stereo modes.

In Manual C-Arm Stereo Mode



In Manual C-arm Stereo Mode, the **C-arm Stereo Mode** button shows on the *Target Guidance* screen. The default is Stereo Mode. Refer to the table that follows for a description of the button function.



Note

The **C-arm Stereo Mode** button shows when the system is set for Manual C-arm Stereo Mode. In Auto C-arm Stereo Mode, this button does not show.

Table 5: The C-arm Stereo Mode Button

Icon	Description of Function
 <p>Figure 47: Stereo Mode</p>	<ul style="list-style-type: none"> • The Tube Arm rotates while the C-arm remains in position. • Select Stereo Mode to acquire stereo images (when the system is set for Manual C-arm Stereo Mode).
 <p>Figure 48: C-arm Mode</p>	<ul style="list-style-type: none"> • The C-arm and Tube Arm rotate together. • Select C-arm Mode to rotate the C-arm and Tube Arm together to a new patient positioning angle.

1. After you set the patient positioning angle (with the C-arm Mode engaged), press the **C-arm Stereo Mode** button on the *Target Guidance* screen to put the C-arm into Stereo Mode.
2. Rotate the Tube Arm to the first 15° angle.
3. Press the **X-ray** button and acquire the first 15° image.
4. Rotate the Tube Arm to the opposite 15° angle.
5. Press the **X-ray** button and acquire the opposite 15° image.



Note

Keep the **X-ray** button pressed until the exposure stops. An audible beep indicates that image acquisition has finished.

5.2.2 How to Select the C-Arm Stereo Mode for Image Acquisition

Table 6: How to Select the C-Arm Stereo Mode

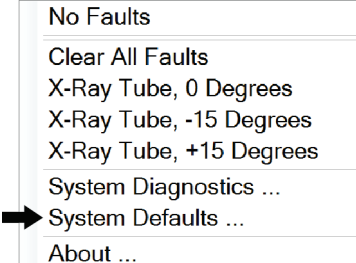
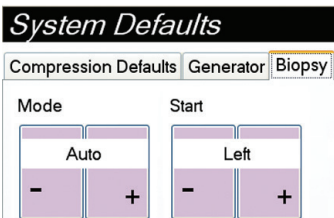
<p>1. Select the System Status icon.</p>	 <p>Figure 49: System Status Icon</p>
<p>2. Select System Defaults from the <i>System Status</i> menu.</p>	 <p>Figure 50: System Status Menu</p>
<p>3. Select the Biopsy tab in the <i>System Defaults</i> screen.</p> <p>4. Select Auto or Manual from the Mode section.</p>	 <p>Figure 51: System Defaults Screen</p>

5.3 Biopsy Tab

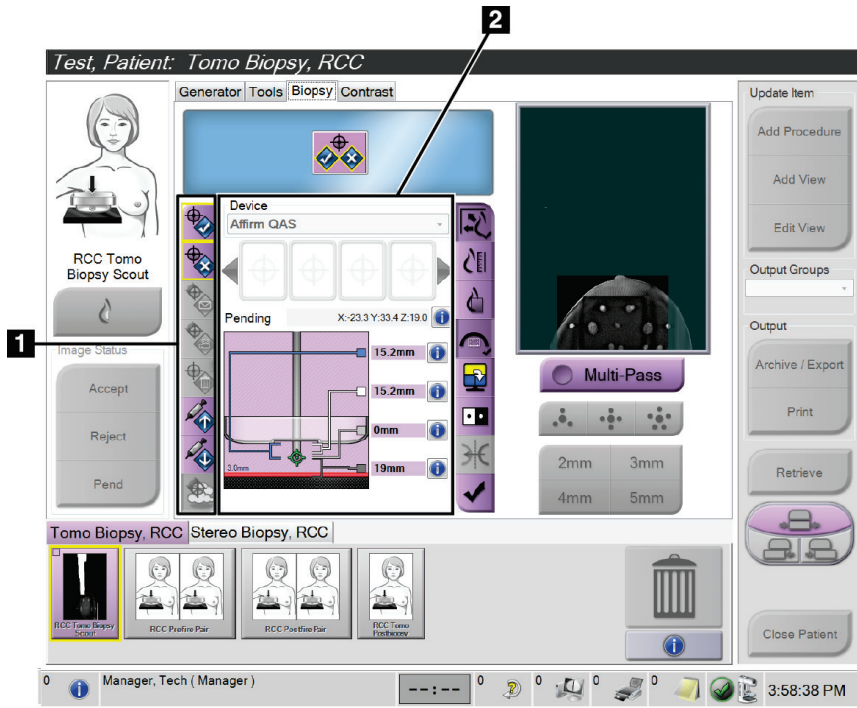

Figure Legend

- 1. Target Function Buttons
- 2. Biopsy Options Area

Figure 52: The Biopsy Tab

When you select the **Biopsy** tab in the *Procedure* screen, the Biopsy Options appear. The Biopsy Options area of the screen shows information about the targets and the biopsy device installed on the system. The buttons on the left side of this area let you send selected targets to the Biopsy Control Module. Refer to [Biopsy Options](#) on page 57 for information about the button functions and data fields on the **Biopsy** tab.

5.3.1 Biopsy Options

The buttons in the Biopsy Options area communicate target information to the Biopsy Control Module. The area on the right side of the buttons shows the selected target and biopsy device.

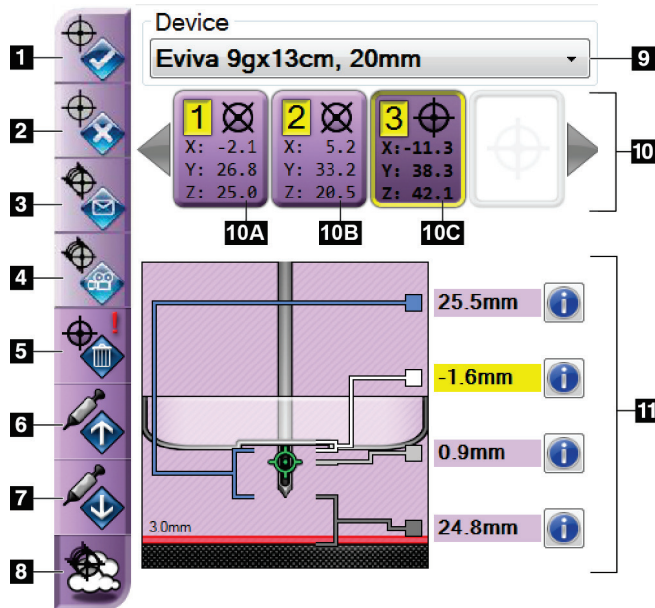

Figure Legend

1. Create Target Button
2. Reject Target Button
3. Resend Target Button
4. Project Target Button
5. Delete Target Button
6. Move Z-Target Up Button
7. Move Z-Target Down Button
8. Show/Hide Targets Button
9. Selected Biopsy Device
10. Target Set
11. Status Indicators

Figure 53: Function Buttons and Data on the Biopsy Tab
(Standard Needle Approach)

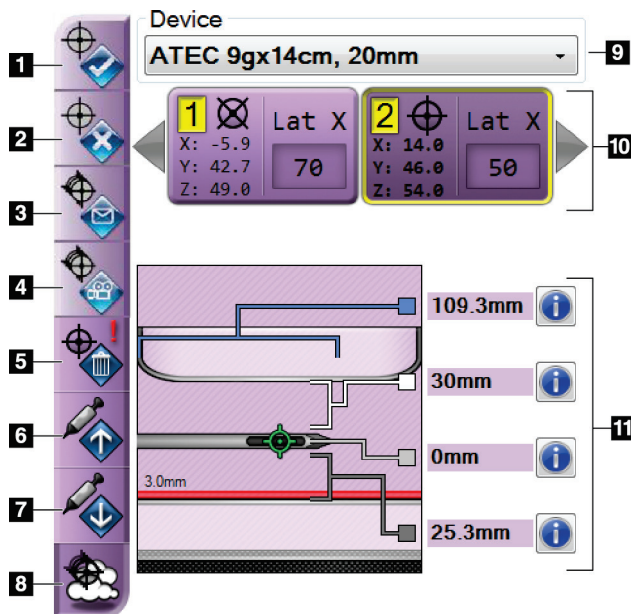

Figure Legend

1. Create Target Button
2. Reject Target Button
3. Resend Target Button
4. Project Target Button
5. Delete Target Button
6. Move Z-Target Up Button
7. Move Z-Target Down Button
8. Show/Hide Targets Button
9. Selected Biopsy Device
10. Target Set
11. Status Indicators

Figure 54: Function Buttons and Data on the Biopsy Tab
(Lateral Needle Approach)

Figure Legend

1. **Create Target** assigns target point(s) and creates a target icon in the target set (item 10). After you assign your target, click the button a second time to accept the target and transfer the target coordinates to the Biopsy Control Module.
2. **Reject Target** removes the selected target from the list of target icons if that target was not yet accepted.
3. **Resend Target** resends the selected target coordinates to the Biopsy Control Module.
4. **Project Target** shows the selected target on an additional stereo pair on the Preview screen.
5. **Delete Target** deletes the selected target from the list of target icons if that target was accepted.
6. **Move Z-Target Up** moves the final position of the needle away from the Breast Platform and the graphic of the lesion downward. The values for the safety margins change accordingly.
7. **Move Z-Target Down** moves the final position of the needle toward the Breast Platform and the graphic of the lesion upward. The values for the safety margins change accordingly.
8. **Show/Hide Targets** shows/hides all target icons in the list of targets.
9. **Device** shows the name of the attached biopsy device that was selected from the related drop-down list.



Warning:

Patient injury can occur if the device you select in the Biopsy tab is not the device that is installed on the system.



Note

If your biopsy device does not show in the drop-down menu, contact Technical Support. A Service Engineer must enter the device specifications.

10. **Target Set** displays all the biopsy targets that have been assigned and/or accepted in this session. You can generate multiple targets as long as the total of all target points are six or less. Use the left and right arrow keys to scroll through the target set if necessary.
- Target #1 - The "1" indicates the target number that has been assigned and is accepted (based on the creation order). A yellow border around the target indicates that it is the active target at the Biopsy Control Module. A single point in the crosshairs indicates that it is a single point target. An asterisk (*) indicates that the target coordinates were later changed at the Biopsy Control Module.
 - Target #2 - The "2" indicates that the target number has been assigned and is accepted (based on the creation order). Multiple points in the crosshairs indicate that it is a multiple point target generated by the Multi-Pass feature (refer to [Lesion Targeting Using Multi-Pass](#) on page 66).
 - Target blank - No number indicates that the coordinates were assigned but not accepted (a user has not yet clicked the **Create Target** button a second time). A single point in the crosshairs indicates that it is a single point target. A depressed target icon indicates that it is the active target *on the user interface*.



Note

The coordinates displaying on a Multi-Pass target icon represent the center point. Right click and hold on the target icon to view the coordinates of all of the points.

11. **Status Indicators** show the distance information:

- The distance between the Biopsy Paddle and the top of the aperture.
- The distance of the target from the center of the aperture.
- The distance from the needle tip (post fire) to the breast platform.
- The distance from the Biopsy Paddle to the needle tip.

The distance indicator fields change colors with movement of the needle.

- Purple indicates that it is safe to proceed.
- Red indicates that the current coordinates exceed the safety margin.
- Yellow warns of being near the safety limit.



Note

To make a target active *for the Affirm system*, select a target icon from the target set and click the **Resend** button.

5.4 Stereotactic 2D Lesion Targeting



Note

You can use the Zoom tool (in the Tools tab or View Actual Pixels button) to magnify the area of interest in an image.



Note

If the exam data in the image blocks detection of the lesion, click the Information icon in the Tools tab to hide the data.



Note

Make sure that the biopsy device is out of the imaging area.



Note

The overall targeting accuracy is equal to the combined targeting accuracy of the Biopsy Guidance Module and the biopsy device. When using the biopsy device, the maximum deviation from the target coordinate will not be more than 2 mm from either side.

1. Select the **Accept** button to save the stereo images.
-



Note

Your Service representative can configure the system to Auto-Accept new images.

2. Click in the area of interest of the lesion in one of the stereo images.
 3. Click the other stereo image, then click in the area of interest of the lesion.
 4. Select the **Create Target** button to save the target. The active target set automatically transmits to the Biopsy Control Module with the creation of each new target.
 5. Repeat this procedure to create multiple targets (a maximum of six).
-



Note

The target that shows on the *Target Guidance* screen of the Biopsy Control Module is the last target created. The target or target set that shows on the *Select Target* screen is the last target or target set sent to the Biopsy Control Module.



Note

To target a lesion, you can also use the Scout and one of the stereo images.

5.4.1 Verify the Position of the Biopsy Device

If desired, use the following steps to verify the position of the biopsy device.

1. Acquire the pre-fire images as necessary to identify the correct needle position.
 - Verify the needle position.
 - Make adjustments as necessary.
2. If applicable, fire the biopsy device.
3. If desired, acquire the post-fire images.
 - Verify the needle position.
 - If necessary, make adjustments.
4. If desired, acquire specimens with the attached biopsy device.
5. If desired, acquire post procedure images.

5.5 Lesion Targeting with Tomosynthesis Guidance

Lesion targeting for tomosynthesis guided procedures requires system licenses for tomosynthesis and biopsy.



Note

Make sure that the biopsy device is out of the imaging area.



Note

The overall targeting accuracy is equal to the combined targeting accuracy of the Biopsy Guidance Module and the biopsy device. When using the biopsy device, the maximum deviation from the target coordinate will not be more than 2 mm from either side.

1. Acquire the tomosynthesis target (scout) image.
 - If your system is set to Auto Accept, the tomosynthesis target (scout) cine runs briefly and then the system automatically accepts the image.
 - If Auto Accept is not set, the cine stops after two passes through the slice deck (or if the **Accept** button is pressed before the second cine run finishes).
2. Use the scroll wheel to scroll through the slices of the tomosynthesis target (scout) to find the best view of the lesion.
3. Click on the lesion.
 - A dash appears in the Slice Indicator beside the selected slice.
 - The X, Y, and Z values for the target are established automatically at the area of the click.
4. Select the **Create Target** button to save the target. The active target set automatically transmits to the Biopsy Control Module.
5. Repeat steps 2 through 4 to create multiple targets (a maximum of six).



Note

The target that shows on the *Target Guidance* screen of the Biopsy Control Module is the last target created. The target or target set that shows on the *Select Target* screen is the last target or target set sent to the Biopsy Control Module.

5.5.1 Verify the Position of the Biopsy Device

If desired, use the following steps to verify the position of the biopsy device.

1. Acquire the pre-fire images as necessary to identify the correct needle position.
 - Verify the needle position.
 - Make adjustments as necessary.
2. If applicable, fire the biopsy device.
3. If desired, acquire the post-fire images.
 - Verify the needle position.
 - If necessary, make adjustments.
4. If desired, acquire specimens with the attached biopsy device.
5. If desired, acquire post procedure images.

5.5.2 Project Targets on Post-Fire Scout Image

To project targets from the pre-fire tomosynthesis target (scout) onto the post-fire tomosynthesis target (scout), follow these steps:

1. Select the pre-fire tomosynthesis target (scout) thumbnail. The image shows in the bottom half of a 2-Up screen on the Image Display monitor.
2. Select the post-fire tomosynthesis target (scout) thumbnail. The image shows in the bottom half of the 2-Up screen.
3. Select the **Project Target** button in the Biopsy Options area to show the pre-fire targets on the post-fire tomosynthesis target (scout).

5.6 Lesion Targeting Using Multi-Pass



Note

The Multi-Pass feature is not available when using the Lateral Arm.



Note

The overall targeting accuracy is equal to the combined targeting accuracy of the Biopsy Guidance Module and the biopsy device. When using the biopsy device, the maximum deviation from the target coordinate will not be more than 2 mm from either side.

The Multi-Pass feature allows you to automatically generate up to five offset target points all equidistant (up to 5 mm away) from the original target.

Multi-Pass can work with either stereo or tomosynthesis biopsy images.

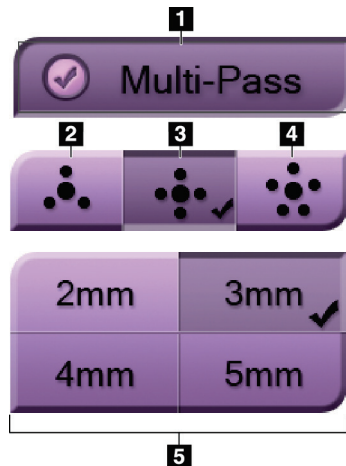

Figure Legend

- 1 - Multi-Pass Selection
- 2 - Three Offset Points
- 3 - Four Offset Points (default)
- 4 - Five Offset Points
- 5 - Offset Point Distances (3 mm is default)

Figure 55: Multi-Pass Options



Note

Make sure that the biopsy device is out of the imaging area.

1. Acquire a stereo pair or tomosynthesis image.
2. Locate the region of interest for the lesion. Click on the lesion, either on both stereo images or on the best slice if a tomosynthesis image.
 - A circle with crosshairs displays around the target point.
 - The X, Y, and Z values for the target are established at the lesion.
 - Tomosynthesis images] A line appears in the Slice Indicator beside the selected slice.
3. Select the **Create Target** button. A target coordinates icon displays on the list of targets.
4. Select the **Multi-Pass** button.

5. Select the number of offset target points (three, four, or five) you require around the center target point.

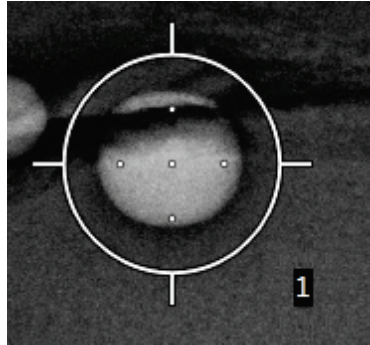

Figure 56: Four Offset Target Points Established Around Center Target Point



Note

Keep in mind that the center target point is included in the total target points. Choosing a "four" offset, for example, generates a total of five target points.

6. Select how far the offset target points are automatically generated from the center target point - 2 mm, 3 mm (the default), 4 mm, or 5 mm.

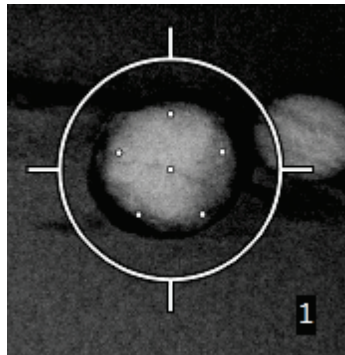

Figure 57: 3 mm Spacing of Offset Points

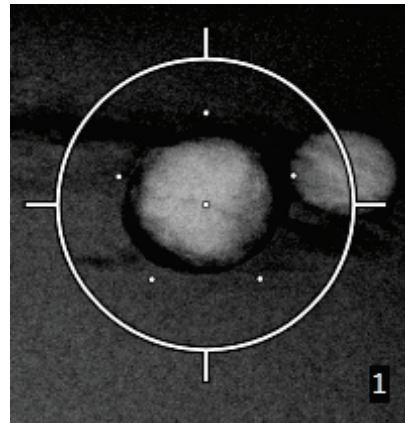

Figure 58: 5 mm Spacing of Offset Points

The crosshairs pattern for the target changes when the target is selected or deselected. See the following figures.

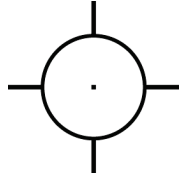

Figure 59: Single Point Target Selected

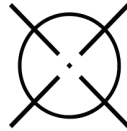

Figure 60: Single Point Target Deselected

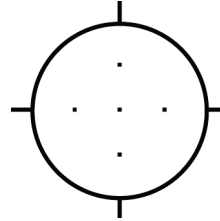

Figure 61: Multi-Pass Target Selected

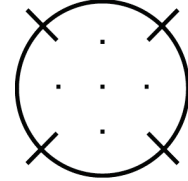

Figure 62: Multi-Pass Target Deselected

7. Select the **Create Target** button to accept the Multi-Pass target. The target becomes the active target icon on the target set and the coordinates are sent to the Biopsy Control Module.



Note

The coordinates displaying on a Multi-Pass target icon represent the center point. Left-click and hold on the target icon to view the coordinates of all of the points.



Note

A maximum of six target points can be generated at any one time. As the number of target points increase in the target set being created, the available Multi-Pass options change to reflect the balance of target points that are available for assignment. For example, in a scenario where a single target point has already been created, then only the "three" and "four" offset target options in Multi-Pass become available. This is because the "three" and "four" offset options are the only ones capable of generating six or less target points when totaled with the single target point.

8. The biopsy order of the target points is as follows:

- The number displayed at the bottom right of the crosshairs circle indicates the order between target sets. The first target is labeled "1", the second is "2", and so on. See the following figure.

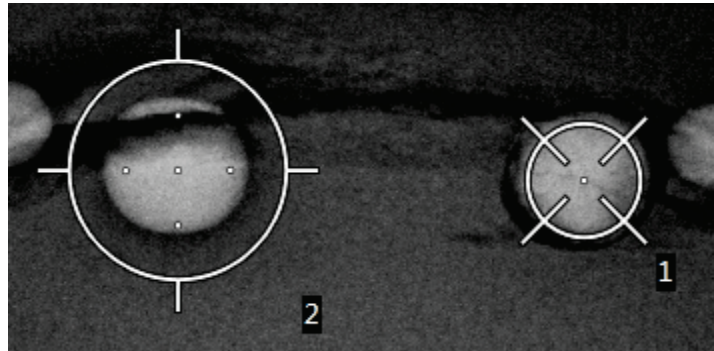

Figure 63: Biopsy Order of Target Sets

- The order within a Multi-Pass target starts at the center target point. After the center target point, the order moves to the 12 o'clock position and continues counter-clockwise through the offset points. See the following figures.

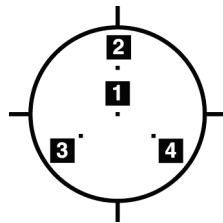

Figure 64: Biopsy Order of a Three Offset Target

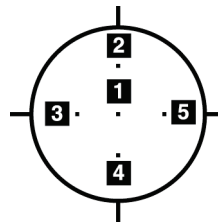

Figure 65: Biopsy Order of a Four Offset Target

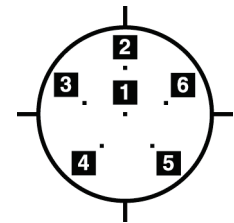

Figure 66: Biopsy Order of a Five Offset Target

9. Verify the position of the Biopsy Device (refer to [Verify the Position of the Biopsy Device](#) on page 63). If necessary, observe the targets on post-Tomosynthesis scout images (refer to [Project Targets on Post-Fire Scout Image](#) on page 65).

5.7 Post Biopsy

1. Put in a biopsy site marker, if desired.
2. Move the biopsy device away from the breast.
3. Acquire images as necessary.
4. Release compression.

5.8 Printing Stereo Pair Images

When you select a stereo pair from the thumbnail area of the *Print* screen, the image mode buttons change. Refer to the imaging system *User Guide* for instructions on use of the *Print* screen.

- Select the -15 button to show that stereo image in the display area.
- Select the +15 button to show that stereo image in the display area.
- Select the middle button to make a 2-up horizontal film with the +15 degree image on top and the -15 degree image on the bottom.

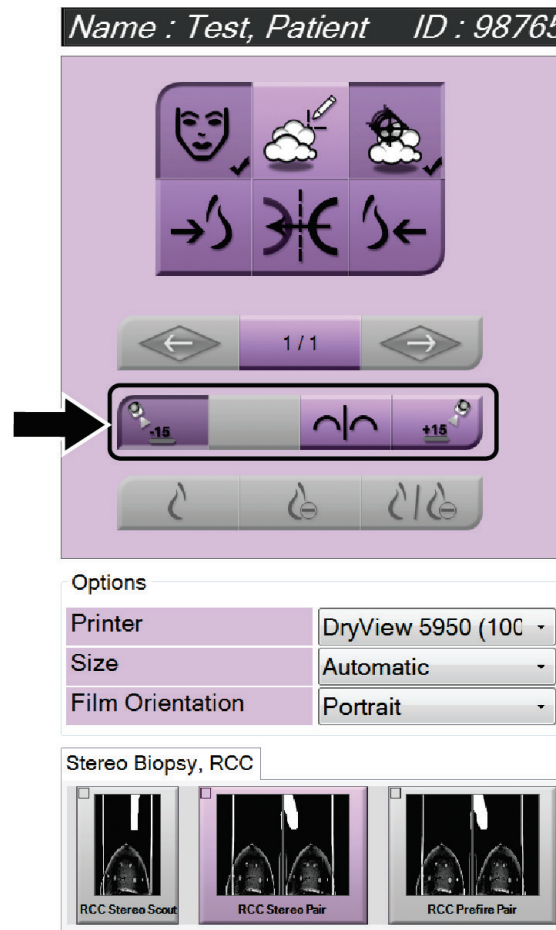

Figure 67: Stereo Pair Print Screen

Chapter 6 Quality Control

MQSA has no requirements for interventional procedures (such as breast biopsy). If your facility is ACR accredited for breast biopsy, refer to the 1999 ACR Stereotactic Breast Biopsy Quality Control Manual on how to do quality control. If your facility is seeking ACR accreditation, refer to the 1999 ACR Stereotactic Breast Biopsy Quality Control Manual to start a quality control program.

Outside of the United States, follow local requirements (such as EUREF guidelines) to create a quality control program for breast biopsy systems).



Note

Refer to [CNR Correction for Biopsy](#) on page 93 for CNR correction factors.

6.1 Required Quality Control Procedures

The following procedures are necessary for correct system operation.

Table 7: Required Procedures

Test	Frequency
QAS Test for Standard Needle Approach	Daily - before clinical use
QAS Test for Lateral Needle Approach	Daily - before clinical use
Geometry Calibration	Semi-annually

6.2 QAS Test

Each day that you plan to use the system, do this test one time to confirm the system accuracy. Record your results in the [QAS Test Checklist](#) on page 95.



Note

You can use Auto C-arm Stereo Mode or Manual C-arm Stereo Mode for the QAS Test. For more information about these modes, refer to [C-Arm Stereo Modes](#) on page 55.

6.2.1 QAS Test for Standard Needle Approach



Caution:

If you use a QAS Needle Phantom, do not extend the needle unless it is attached to the Biopsy Guidance Module and the module is installed on the C-arm.

1. Make sure the Affirm system is installed correctly and all paddles are removed.
2. On the Acquisition Workstation, from the *Select Patient* screen, select the **Admin** button.
3. On the *Admin* screen, select the **QAS** button.



Figure 68: QAS Button on the Admin Screen

The QAS screen opens. A dialog box prompts you to install the QAS phantom and shows the position of the coordinates for the test.



Note

The dialog box says to install the QAS "needle" but is referring to the QAS phantom.

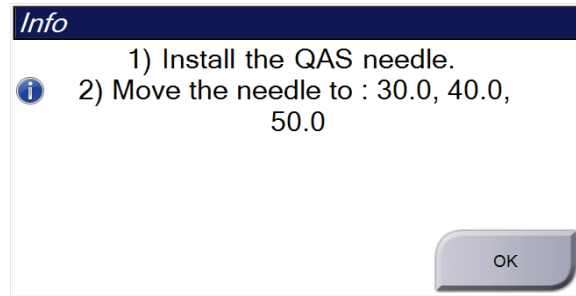

Figure 69: QAS Test Info Dialog Box

4. Install the QAS Phantom. (If the QAS Phantom uses a needle, fully extend the needle.)
5. In the Info dialog box, select **OK**.
6. On the QAS screen, select the **Biopsy** tab. Make sure that **Affirm QAS** appears in the Device field.

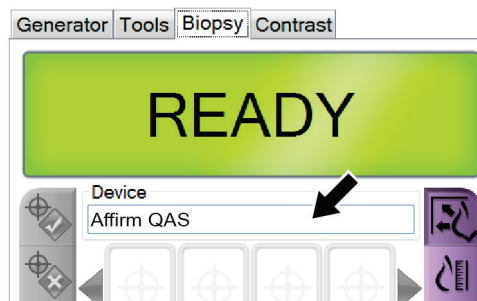

Figure 70: Device Field in the Biopsy Tab

7. Press and hold a right or left **Motor Enable** button pair on the Biopsy Control Module. The QAS Phantom moves automatically to pre-programmed X and Y positions.
8. Turn the Biopsy Device Advance/Retract knob until "0.0" displays on the Diff line in all three columns of the Biopsy Control Module.

9. Select Manual exposure mode, 25 kV, 30 mAs, Rhodium filter in the QAS screen. (If the QAS Phantom uses a needle, select the Manual exposure mode, 25 kV, 10 mAs, Rhodium filter in the QAS screen.)
10. Acquire and accept an image for a view in the procedure. Note that the Auto-Accept feature is not enabled during the QAS procedure and that targeting on the QAS Phantom occurs automatically.



Note

If automatic targeting is not successful, manually select the targets in the images.

11. Select the **Create Target** button to send the target to the Biopsy Control Module. Verify that the target coordinates are within ± 1 mm of X, Y, and Z numbers as shown on the Diff values line of the Biopsy Control Module.



Warning:

If the targeting coordinates are not within ± 1 mm, contact Technical Support. Do not try to adjust the system. Do not perform any biopsy procedure with the Affirm system until Technical Support indicates the system is ready for use.



Warning:

The user or a Service Engineer must correct problems before the system is used.

12. Repeat steps 10 and 11 for all unexposed views.
Tomosynthesis option only: For the Tomo Biopsy QAS view, select Manual exposure mode, 30 kV, 30 mAs, and Aluminum filter. Then repeat steps 10 and 11.
13. At the Acquisition Workstation, select the **End QC** button.
14. At the Biopsy Control Module, press a **Home Position** button (Left or Right) to move the QAS Phantom to the side.
15. Remove the QAS Phantom.

6.2.2 QAS Test for Lateral Needle Approach

1. Make sure the Affirm system is installed correctly and all paddles are removed.
2. On the Acquisition Workstation, navigate to the *Admin* screen.
3. Select the **Lateral QAS** button.



Figure 71: Lateral QAS Button on the Admin Screen

The QAS screen opens. A dialog box prompts you to install the QAS phantom and shows the position of the coordinates for the test.



Note

The dialog box says to install the QAS "needle" but is referring to the QAS phantom.

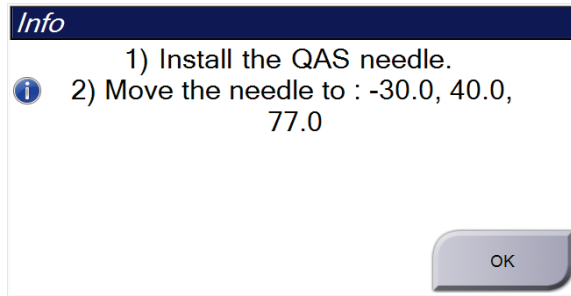

Figure 72: Lateral QAS Test Info Dialog Box

4. Install the Lateral Arm assembly and the Lateral Arm QAS Phantom on the left side of the Affirm system.
5. In the Info dialog box, select **OK**.
6. On the QAS screen, select the **Biopsy** tab. Make sure that **Affirm Lateral QAS** appears in the Device field.



Figure 73: Device Field in the Biopsy Tab

7. Press and hold a right or left **Motor Enable** button pair on the Biopsy Control Module. The QAS Phantom moves automatically to pre-programmed X and Y positions.
8. Turn the Biopsy Device Advance/Retract knob until "0.0" displays on the Diff line in all three columns of the Biopsy Control Module.

9. Move the Lateral Arm carriage assembly to the "Lat X" value shown on the Biopsy Control Module (normally this value is "100"). Use the top scale on the Lateral Arm for the values.
10. Select Manual exposure mode, 25 kV, 30 mAs, Rhodium filter in the QAS screen.
11. Acquire and accept an image for a view in the procedure. Note that the Auto-Accept feature is not enabled during the QAS procedure and that targeting on the QAS Phantom occurs automatically.

**Note**

If automatic targeting is not successful, manually select the targets in the images.

12. Select the **Create Target** button to send the target to the Biopsy Control Module. Verify that the target coordinates are within ± 1 mm of X, Y, and Z numbers as shown on the Diff values line of the Biopsy Control Module.

**Warning:**

If the targeting coordinates are not within ± 1 mm, contact Technical Support. Do not try to adjust the system. Do not perform any biopsy procedure with the Affirm system until Technical Support indicates the system is ready for use.

**Warning:**

The user or a Service Engineer must correct problems before the system is used.

13. Repeat steps 11 and 12 for all unexposed views for that approach side.
14. Move the Lateral Arm assembly to the right side of the Affirm system. Repeat steps 5 through 13.
15. At the Acquisition Workstation, select the **End QC** button.
16. At the Biopsy Control Module, press a **Home Position** button (Left or Right) to move the QAS Phantom to the side.
17. Remove the Lateral Arm assembly.

6.3 Geometry Calibration

Geometry calibration is required semiannually. Perform this calibration using the Geometry phantom supplied with the system.

6.3.1 Geometry Calibration Procedure

1. Inspect the calibration phantom for damage.
2. Select **Admin > Quality Control > Technologist tab > Geometry Calibration** procedure on the Acquisition Workstation.
3. Select **Start**.
4. Follow the instructions on the screen and take the predefined exposure. Do not change the preselected techniques.
5. **Accept** the image. When you see the message that the geometry calibration was completed successfully, click **OK**.
6. Select **End Calibration**.

Chapter 7 Care and Cleaning

7.1 General Information

Before each examination, clean and use a disinfectant on any part of the system and any accessory that touches a patient.

7.2 Preventive Maintenance Schedule

Affirm Biopsy Guidance System

Table 8: Radiologic Technologist Preventive Maintenance Schedule

Maintenance Task Description	Each use	Daily	Semiannually
Clean the Biopsy Paddle with a disinfectant after use.*	✓		
Clean the Breast Platform with a disinfectant after use.*	✓		
Inspect the Biopsy Paddle for damage before use.	✓		
Inspect the calibration Phantom for damage.	✓		
Inspect all cables for wear and damage before use.	✓		
Make sure that the Affirm system locks in position.	✓		
Make sure that the Needle Guides are installed correctly before use.	✓		
Make sure that all displays are illuminated.	✓		
Perform QAS Procedures once each day before use of the system.		✓	
Geometry Calibration (refer to Geometry Calibration on page 78)			✓

*Call Technical Support for the current list of recommended cleaning solutions.

Affirm Breast Biopsy Guidance System User Guide

Chapter 7: Care and Cleaning

Lateral Arm

Table 9: Radiologic Technologist Preventive Maintenance Schedule

Maintenance Task Description	Each use	Daily	Semiannually
Clean all Lateral Arm components with a disinfectant after use.*	✓		
Make sure that all locks and controls function and move smoothly.	✓		
Make sure the Lateral Arm and the position indicators are not bent.	✓		
Make sure that the Lateral Arm locks in position onto the Affirm system.	✓		
Inspect the Needle Guides for form, fit, and function.	✓		
All Components: Inspect for loose or missing hardware.	✓		
Perform QAS Procedures once each day before use of the system.		✓	
Make sure that all labels are readable and properly affixed.			✓

*Call Product Support for the current list of recommended cleaning solutions.
 Perform QAS Procedures after installing a different Lateral Arm.

7.3 Service Preventive Maintenance Schedule

Table 10: Service Engineer Preventive Maintenance Schedule

Maintenance Task Description	Each Visit	6 Months	Annually
Review user concerns or issues.	✓		
Inspect all system components for wear and damage.	✓		✓
Check missing, damaged, or loose hardware. Be sure covers fit tightly.		✓	
Inspect paddles for damage and defects. Replace as necessary.	✓	✓	
Inspect cables and connections for wear and damage.	✓	✓	
Inspect all ground wires for damage and correct connection.			✓
Inspect and clean the unit.		✓	
Verify the calibration of the ±15 degree stereo position.		✓	
Verify the x-ray field for Biopsy Mode.		✓	
Verify all of the Affirm system functions.		✓	
Check compression lockout operation.		✓	
Verify the Affirm system alignment to the C-arm.		✓	
Verify the Needle Guide alignment.			
Verify the Affirm system locks in position on the C-arm.		✓	
Verify the ID sensors correctly identify the Affirm system when installed.		✓	
Install software/ firmware upgrades if required and if under warranty/contract.		✓	
Perform QAS Procedures to confirm target accuracy.		✓	
Complete all required documentation, Preventive Maintenance, and Service Requests. Make an appointment for repair service if required.		✓	

7.4 For General Cleaning

Use a lint-free cloth or pad and apply a diluted dishwashing liquid.



Caution:

Use the least possible amount of cleaning fluids. The fluids must not flow or run.

If more than soap and water is required, Hologic recommends any one of the following:

- 10% chlorine bleach solution and water with one part commercially available chlorine bleach solution (normally 5.25% chlorine and 94.75% water) and nine parts water. Mix this solution daily for best results.
- Commercially available isopropyl alcohol solution (70% isopropyl alcohol by volume, not diluted)
- 3% maximum concentration of hydrogen peroxide solution

After you apply any of the above solutions, use a pad and apply a diluted dishwashing liquid to clean any parts that touch the patient.



Warning:

If a paddle touches possible infectious materials, contact your Infection Control Representative to remove contamination from the paddle.



Caution:

To prevent damage to the electronic components, do not use disinfectant sprays on the system.

7.4.1 How to Clean the Biopsy Control Module Screen

There are many commercially available products to clean LCD screens. Make sure the product that you select is free of strong chemicals, abrasives, bleach, and detergents that contain fluorides, ammonia, and alcohol. Follow the directions of the manufacturer of the product.

7.4.2 To Prevent Possible Injury or Equipment Damage

Do not use a corrosive solvent, abrasive detergent, or polish. Select a cleaning/disinfecting agent that does not damage the plastics, aluminum, or carbon fiber.

Do not use strong detergents, abrasive cleaners, high alcohol concentration, or methanol at any concentration.

Do not expose equipment parts to steam or high temperature sterilization.

Do not let liquids enter the internal parts of the equipment. Do not apply cleaning sprays or liquids to the equipment. Always use a clean cloth and apply the spray or liquid to the cloth. If liquid enters the system, disconnect the electrical supply and examine the system before returning it to use.



Caution:

Wrong cleaning methods can damage the equipment, decrease imaging performance, or increase the risk of electric shock.

Always follow instructions from the manufacturer of the product you use for cleaning. The instructions include the directions and precautions for the application and contact time, storage, wash requirements, protective clothing, shelf life, and disposal. Follow the instructions and use the product in the most safe and effective method.

Appendix A System Specifications

A.1 Affirm System Measurements

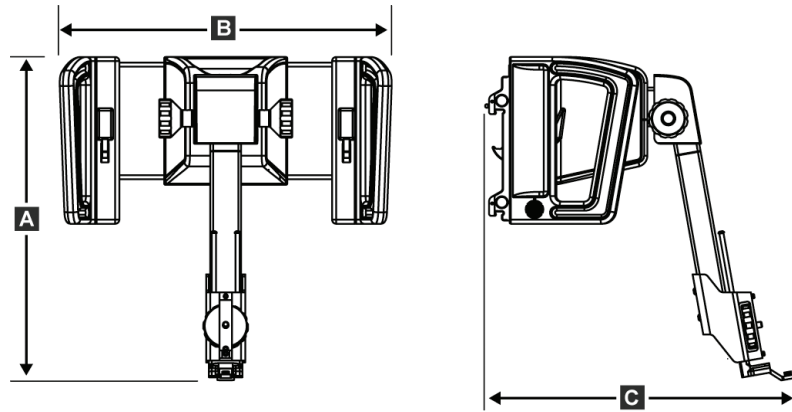

Figure 74: Affirm Biopsy Guidance Module

A. Height	37.1 cm (14.6 inches)
B. Width	37.8 cm (14.9 inches)
C. Depth	35.6 cm (14 inches)
Weight	6.8 kg (15 pounds)

A.2 Lateral Arm Measurements

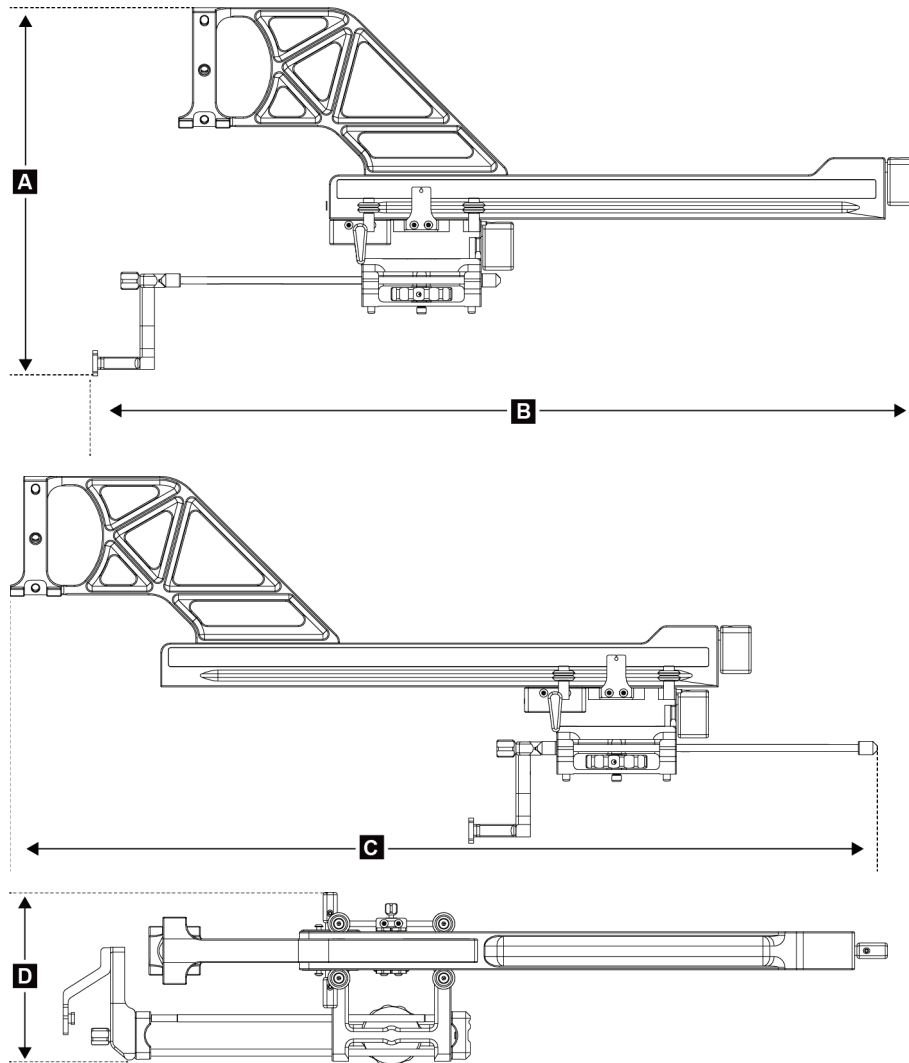

Figure 75: Lateral Arm

A. Height	24.4 cm (9.6 inches)
B. Width (Biopsy Device Mount and Needle Guide extended toward Lateral Arm Mount)	53.0 cm (20.9 inches)
C. Width (Biopsy Device Mount and Needle Guide retracted toward Lateral Arm Mount)	57.4 cm (22.6 inches)
D. Depth	11.5 cm (4.5 inches)
Weight	1.24 kg (2.73 pounds)

A.3 Biopsy Guidance Module

<i>Accuracy of Biopsy Guidance Module</i>	<i>maximum deviation: 1 mm in either direction of target coordinate</i>
<i>Combined Accuracy of Biopsy Guidance Module and Biopsy Device</i>	<i>maximum deviation: 2 mm in either direction of target coordinate</i>
<i>Range of Movement</i>	<i>X-axis: ± 35 mm</i> <i>Y-axis: + 72.8 mm</i> <i>Z-axis: + 161 mm</i>
<i>Speed of Motorized Movements</i>	<i>Continuous: No faster than 5 mm per second</i> <i>Incremental: 0.5 mm steps</i>
<i>Power System</i>	<i>Input from Selenia Dimensions system or 3Dimensions system:</i> <i>+ 15 Vdc ± 10% and + 5 Vdc ± 10%</i> <i>Output: + 12 Vdc</i>

A.4 Lateral Arm

<i>Accuracy of Biopsy Guidance Module and Lateral Arm</i>	<i>maximum deviation: 1 mm in either direction of target coordinate</i>
<i>Combined Accuracy of Biopsy Guidance Module, Lateral Arm, and Biopsy Device</i>	<i>maximum deviation: 2 mm in either direction of target coordinate</i>
<i>Range of Movement</i>	<i>Lateral X-axis: 22 cm</i>

A.5 Biopsy Control Module

<i>Display Window</i>	<i>Touch screen controls</i>
<i>Weight</i>	<i>3 pounds</i>
<i>Power System</i>	<i>Input from Biopsy Guidance Module: + 5 Vdc ± 10%</i>

Appendix B System Messages and Alerts

B.1 Audible Alerts

Table 11: Affirm System Audible Alerts

Activity	Frequency	Duration	Repeats?
At Power Up:	3	250 ms	No
Any Needle position within the safety margin limit:	1	50 ms	Yes
Start of each Move, including Jog:	1	250 ms	No

B.2 Error Messages

Table 12: Affirm System Error Messages

Error Message	How to Correct
No Device Select	Select a biopsy device.
No Paddle	Install a biopsy paddle.
User is not logged in	Log in at the Acquisition Workstation.
Unit is unlatched	Put both lock levers into the locked position (see the figure Installation of the Biopsy Guidance Module on page 16).
Unknown Error	<ol style="list-style-type: none"> In the taskbar of the imaging system software, select the system status icon. In the menu, select Clear All Faults. If the message continues to display, contact Technical Support.
Unrecoverable Error	Contact Technical Support. Software must be reloaded.
Safety Margin Infringement	Move the biopsy device outside of the safety margin. Press the Sound button to mute the warning sound.
Calibration Required	Contact Technical Support.
Motion Fault	<ol style="list-style-type: none"> In the taskbar of the imaging system software, select the system status icon. In the menu, select Clear All Faults. Another message that is related to the cause of this error can appear. If the <i>Motion Fault</i> message continues to display, contact Technical Support.

Affirm Breast Biopsy Guidance System User Guide

Appendix B: System Messages and Alerts





Table 12: Affirm System Error Messages

Error Message	How to Correct
Comm Error	<ol style="list-style-type: none">1. In the taskbar of the imaging system software, select the system status icon.2. In the menu, select Clear All Faults. <p>This error can occur when the manual Z-control is turned quickly.</p>
Hardware Error	<ol style="list-style-type: none">1. In the taskbar of the imaging system software, select the system status icon.2. In the menu, select Clear All Faults.3. If the message continues to display, contact Technical Support.
Selftest Error	<ol style="list-style-type: none">1. Disconnect the Affirm Biopsy Guidance Module cable from the imaging system.2. Reconnect the Affirm Biopsy Guidance Module cable to the imaging system.3. If the message continues to display, contact Technical Support.
Stuck Switch Fault	<ol style="list-style-type: none">1. Disconnect the Biopsy Control Module cable from the Biopsy Guidance Module.2. Reconnect the Biopsy Control Module cable to the Biopsy Guidance Module.

B.3 Acquisition Workstation Messages

When the following system messages show, do the step shown in the User Action column to clear the message.

Table 13: Acquisition Workstation Messages

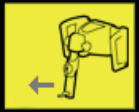
Icon	Message	User Action
	Affirm cable is not connected	Connect the Affirm system cable to the side of the Gantry.
	Affirm is not locked	Lock each side of the Affirm system.
	BCM cable is not connected	Connect the Biopsy Control Module cable to the side of the Affirm system.
	View requires Affirm to be installed OR View cannot be completed with Affirm installed	Install the Affirm system to acquire this view. OR Remove the Affirm system to acquire this view.
	The needle needs to be moved to the correct location.	Move the needle to the correct location for Biopsy QAS.

Appendix C CNR Correction for Biopsy

C.1 CNR Correction for Stereotactic 2D Biopsy



Note

System default setting is AEC Table 0 for imaging under stereotactic 2D biopsy mode.

C.1.1 AEC Table 0 (Standard Stereotactic 2D Biopsy Dose)

Compression Thickness	Prior to Software Rev 1.7.x	After Software Rev 1.7.x	
	All Detectors	Detector Serial #: XX6xxxxx	Detector Serial #: XX8xxxxx
2.0 cm	0.91	0.91	0.91
4.0 cm	1.00	1.00	1.00
6.0 cm	1.27	1.27	1.32
8.0 cm	1.76	1.76	1.88

C.2 CNR Correction for Biopsy Under Tomosynthesis Option



Note

System default setting is AEC Table 0 (Tomosynthesis Option) for imaging under biopsy mode using digital breast tomosynthesis.

C.2.1 AEC Table 0 (Tomosynthesis Option: Standard Tomo Dose)

Compression Thickness	Prior to Software Rev 1.7.x	After Software Rev 1.7.x	
	All Detectors	Detector Serial #: XX6xxxxx	Detector Serial #: XX8xxxxx
2.0 cm	0.70	0.70	0.70
4.0 cm	0.91	0.91	0.91
6.0 cm	1.46	1.46	1.55
8.0 cm	2.37	2.37	2.78

Appendix E Ancillary Parts for Biopsy

E.1 Hologic Factory-Verified Biopsy Devices

Table 14: Hologic Factory-Verified Biopsy Devices

Manufacturer	Description	Model
Hologic	Affirm QAS Needle	ASY-03949
Hologic	Affirm with Lateral Arm QAS Needle	ASY-09506
Hologic	ATEC® 9 g x 12 cm, 12 mm (Petite)	ATEC 0912-12
Hologic	ATEC 9 g x 12 cm, 20 mm	ATEC 0912-20
Hologic	ATEC 12 g x 12 cm, 20 mm	ATEC 1212-20
Hologic	ATEC 9 g x 9 cm, 12 mm (Petite)	ATEC 0909-12
Hologic	ATEC 9 g x 9 cm, 20 mm	ATEC 0909-20
Hologic	ATEC 12 g x 9 cm, 20 mm	ATEC 1209-20
Hologic	ATEC 9 g x 14 cm, 20 mm	ATEC 0914-20
Hologic	Brevera® 9 g x 13 cm, 20 mm (Standard) or 12 mm (Petite)	BREV09
Hologic	Brevera® 9 g x 13 cm, 20 mm (Standard) or 12 mm (Petite)	BREVDISP09
Hologic	Eviva® 9 g x 13 cm, 12 mm (Blunt Petite)	Eviva 0913-12
Hologic	Eviva 9 g x 13 cm, 12 mm (Trocar Petite)	Eviva 0913-12T
Hologic	Eviva 9 g x 13 cm, 20 mm	Eviva 0913-20
Hologic	Eviva 12 g x 13 cm, 20 mm	Eviva 1213-20
Hologic	Eviva 9 g x 10 cm, 12 mm (Blunt Petite)	Eviva 0910-12
Hologic	Eviva 9 g x 10 cm, 12 mm (Trocar Petite)	Eviva 0910-12T
Hologic	Eviva 9 g x 10 cm, 20 mm	Eviva 0910-20
Hologic	Eviva 12 g x 10 cm, 20 mm	Eviva 1210-20
Hologic	LOCALizer 12 g x 10 cm	LOCALizer 09-0003
Hologic	LOCALizer S 12 g x 10 cm	LOCALizer 09-0003S
Hologic	PERL 16 g x 11.5 cm, 1 cm Ring	PERL R10
Hologic	PERL 16 g x 11.5 cm, 1.5 cm Ring	PERL R15
Hologic	PERL 16 g x 11.5 cm, 2 cm Ring	PERL R20

E.2 Wire Localization Needle Guides

The following table provides the part numbers of the wire localization (loc) needle guides. These items can be ordered by either calling 1-877-371-4372 and following the prompts for parts or sending an email to Parts@hologic.com. Outside of the USA, contact your local Hologic dealer.

<i>Table 15: Wire Localization (Loc) Needle Guides</i>			
Part Number	Description	Color, Quantity in each package	Use
3-425-4002	Sterile Pack, Open Needle Guide 16-19 Gauge	Purple, 2	For 16-19 GA needles when sites are leaving both needle and wire in breast
3-425-4003	Sterile Pack, Open Needle Guide 20-22 Gauge	Purple, 2	For 20-22 GA. needles when sites are leaving both needle and wire in breast
3-425-4004	Sterile Pack, Closed Needle Guide 16-19 Gauge	Yellow, 2	For 16-19 GA. needle when sites are leaving only the wire in breast
3-425-4005	Sterile Pack, Closed Needle Guide 20-22 Gauge	Yellow, 2	For 20-22 GA. needle when sites are leaving only the wire in breast
3-255-0004	Sterile Pack, Closed Needle Guide 14 Gauge	Green, 1	For 14 GA. needle; or QAS on MultiCare Platinum and Stereo Loc II systems

Glossary of Terms

Affirm System

The breast biopsy guidance system for the Selenia Dimensions and 3Dimensions imaging systems

Biopsy Control Module

The user control device for the breast biopsy guidance system

Biopsy Guidance Module

Holds and operates the biopsy device. Responds to commands from the Biopsy Control Module to move the device into position and do the biopsy.

C-Arm Mode

Lets the C-arm and Tube Arm move together to the Needle Approach angle for the Localization procedure.

Exposure Technique

Combination of x ray parameters (kVp, mAs, filter) for an acquired image

Gantry

A part of the Selenia Dimensions and 3Dimensions systems that has the Detector, Generator and X-ray Source, Positioning/Compression, Power Distribution, and Accessories Subsystems

Multi-Pass

Allows you to automatically generate up to five offset target points all equidistant (up to 5 mm away) from the original target point

Needle Approach Angle

The angle of incidence of the needle to the breast

QAS

Quality Assurance Standard

Safety Margins

The minimum space allowed between the biopsy device needle tip that is installed and components of the system (for example, image receptor or paddle)

Stereo Mode

Lets the Tube Arm rotate for acquisition of stereotactic images while the C-arm stays in position.

Stereotactic Procedure

A type of examination that allows stereotactic views at the Acquisition Workstation.

Stereotactic View

A specialized image view that causes the application to capture stereotactic images

Stroke Margin

The safety margin (in mm) which remains between the fired needle position and the breast platform. This margin is calculated by the system according to the "Z" coordinate, the Stroke, and the compression amount.

Tomosynthesis

An imaging procedure that combines a number of breast images taken at different angles. The tomosynthesis images can be reconstructed to show focal planes (slices) within the breast.

View

The combination of one x-ray image and a specified set of conditions for image acquisition

Index

A

- adjustment
 - biopsy control module position • 18
 - bracket height • 18
 - control module position • 18
- Affirm system storage • 38
- attachment
 - biopsy control module • 17
- auto biopsy mode • 55
- auto C-Arm stereo mode • 55

B

- biopsy control module • 15
- biopsy device precautions with lateral arm • 20
- biopsy geometry calibration • 78
- biopsy modes
 - auto • 55
 - manual • 55
- biopsy views • 51
- bracket height, adjustment • 18

C

- calibration
 - biopsy geometry • 78
- C-Arm stereo modes
 - C-arm rotation • 55
- CNR correction for biopsy • 93
- component controls
 - biopsy control module • 15
- component removal
 - biopsy control module • 37
 - biopsy guidance module • 37
- control module position, adjustment • 18
- control module screens • 41
 - home screen • 41

G

- general information • 7

H

- Hologic technical support • 79

- home screen • 41
- host connection verification • 36

I

- information
 - general • 7
- installation
 - biopsy control module • 17
 - biopsy device adapter, lateral arm • 32
 - biopsy guidance module • 16
 - device mount, lateral arm • 30
 - lateral arm • 24
 - needle guides, lateral arm • 28
 - X-Stop • 34

L

- lateral approach • 21
- lateral arm • 21
 - biopsy device adapter, lateral arm • 32
 - biopsy device precautions with lateral arm • 20
 - device mount, lateral arm • 30
 - installation, lateral arm • 24
 - lateral arm stand • 24
 - needle guides, lateral arm • 28
 - overview, lateral arm • 21
 - X-Stop • 34
- lateral arm storage • 39
- lesion targeting
 - stereotactic lesion targeting • 62
 - tomosynthesis lesion targeting • 64

O

- overview, lateral arm • 21

Q

- QAS test • 71

R

- removal
 - biopsy control module • 37
 - biopsy device adapter, lateral arm • 32
 - biopsy guidance module • 37
 - device mount, lateral arm • 30

- lateral arm • 24
- needle guides, lateral arm • 28
- X-Stop • 34
- requirements
 - training • 2

S

- skills needed • 1
- specifications • 85
- stereo biopsy mode
 - C-arm rotation • 55
- stereo views • 51
- stereotactic lesion targeting • 62
- storage, lateral arm • 39
- system
 - host connection verification • 36
 - specifications • 85
 - verification • 36

T

- Table-top Stand
 - Affirm system storage • 38
- target lesion
 - stereotactic lesion targeting • 62
 - tomosynthesis lesion targeting • 64
- technical support • 3
- tomosynthesis lesion targeting • 64
- training requirements • 2

X

- X-Stop • 34

HOLOGIC®



Hologic, Inc.
36 Apple Ridge Road
Danbury, CT 06810 USA
1-800-447-1856

Brazilian Contact

Imex Medical Group do Brasil
Rua das Embaúbas, 601
Fazenda Santo Antônio
São José/SC
88104-561 Brasil
+55 48 3251 8800
www.imexmedicalgroup.com.br

EC	REP
----	-----

Hologic BV
Da Vincilaan 5
1930 Zaventem
Belgium
Tel: +32 2 711 46 80
Fax: +32 2 725 20 87

CE
2797

Refer to the corporate website for more facilities worldwide.
www.hologic.com