

Hologic Affirm[®] Prone Biopsy System

Introducing the first and only dedicated prone stereotactic biopsy system with 2D/3D[™] imaging.

Hologic brings 3D[™] imaging to prone procedures and enables high-resolution 2D imaging – for those who haven't yet moved to 3D[™] breast screening. Explore the technical details of the Hologic Affirm prone biopsy system on the following pages.



Superior image quality.*

Using the same proven detector technology as our Selenia[®] Dimensions[®] mammography system, Hologic's Affirm[®] prone system helps you pinpoint subtle lesions and faint calcifications found during mammography exams.



Streamlined workflow.

With automated tube-head motion, programmed biopsy needle parameters, and one-click targeting for 3D[™] breast biopsies, you can generate high quality images in seconds – for fast procedures and an exceptional patient experience.



Easy 360° breast access.

A fully integrated C-arm enables 360° breast access to challenging lesions. Go seamlessly from standard to our exclusive lateral needle approach to accelerate procedures.

*Compared to MultiCare Platinum

Technical Specifications

Overall System Specifications

General Operating Conditions	
Temperature range	10°C to 30°C (50°F - 86°F)
Max rate of temperature change	10°C per hour
Relative humidity range	10% to 80%, non-condensing

Electrical Specifications

System Protection	
Uninterruptable power supply	700 VA, 420 W output power
Electrical Requirements	
Input line voltage	200/208/220/230/240 VAC ±10%
Average line current over 24 hours	< 5 A
Peak line current	4 A (65 A maximum for < 5 seconds)
Frequency	50/60 Hz ±5%

General Specifications

Acquisition Workstation	
CPU type	Multi-core Intel
Memory	4 GB
Hard drive size	1 TB
Operating system	Windows 10
Ethernet	100/1000 BASE-T Ethernet
Height range (Floor to work surface)	71.1 cm (28 in) to 111.8 cm (44 in)
Adjustable vertical travel	40.6 cm (16 in)
Adjustment type	Electronic
Removable storage	CD/DVD +/- R/W
USB ports	6X USB 2.0
Local image buffer	2D Images: 200,000 images 3D™ Images: 5,000 images
Workflow display monitor	17" 1280 x 1024 resolution
Image display monitor	2 MP or 3 MP DICOM display

X-ray Gantry Specifications

Gantry Mechanics	
Gantry weight	445 kg (980 lbs.)
Generator weight	136 kg (300 lbs.)
Acquisition workstation weight	114 kg (252 lbs.)
Patient Support Platform	
Type	Bidirectional patient positioning
Motorized height range	86.4 - 145 cm (34 - 57 in)
Patient weight limit (lift and support)	181.4 kg (400 lbs.)
Lighting	LED: Under table and biopsy field work light
C-arm	
Design	Fully integrated and independently rotating tube-arm, biopsy arm, detector mechanism
Lateral needle approach	Fully integrated into biopsy arm
Rotation	180° continuous
Source-Image Distance (SID)	80 cm (31.5 in)
Breast Compression	
Pre-compression	Motorized
Compression	Manual, handwheel driven
Release	Motorized
Controls	Handwheel or footswitch
Manual compression force	67.4 lb. (300 N) maximum
Motorized compression force	14 lb. (62.3 N) minimum 45 lb. (200 N) maximum
Paddles	5 cm x 5 cm (biopsy window) standard, 6 cm x 7 cm standard, 5 cm x 5 cm axillary, 15 cm (total width) lateral

Digital Image Receptor

Technology	
Type	TFT-based direct capture
X-ray absorption material	Amorphous selenium
Image receptor size (H x W)	33 cm (13 in) x 21.5 cm (8.46 in)
Field of view size	14.3 cm (5.63 in) x 11.7 cm (4.6 in)
Pixel size	70 µm
Limiting spatial resolution	2D: 7.1 lp/mm 3D™ procedure: 7.1 lp/mm
Dynamic range	Linear response over greater than 400:1 dynamic range
Captured image bit depth	14 bit
Geometric magnification	1.18
Storage Environment	
Storage temperature range	10°C to 35°C
Relative humidity range	10% to 80%, non-condensing

X-ray Subsystem

Stand-Alone Generator	
Type	Constant potential three-phase high frequency inverter
Rating	7.0 kW (large focus) maximum, at 34kV)
Electrical power capacity	9.0 kW maximum
kV Range	20-49 kVp in 1 kVp increments
mAs Range	3-500 mAs, 45 steps: 3.2, 3.6, 4, 4.5, 5, 5.6, 6.3, 7.1, 8, 9, 10, 11, 12.5, 14, 16, 18, 20, 22, 25, 28, 32, 36, 40, 45, 50, 56, 63, 71, 80, 90, 100, 110, 125, 140, 160, 180, 200, 220, 250, 280, 320, 360, 400, 450, 500 mAs
mA Range	10-200 mA
X-ray Tube	
Anode type	Tungsten
Focal spot size	0.3 mm nominal
Filtration	Aluminum, 0.70 mm nominal Silver, 0.050 mm +/- 10%
Port	Beryllium

Biopsy Guidance

Specifications	
Needle guidance	Cartesian coordinate
Accuracy	+/- 1 mm
Stereotactic angle	+/- 15°
Tomosynthesis angle	+/- 7.5°
Guidance movements	2 axis motorized, manual advance needle into the breast
Range of movement	Horizontal: -3.5 cm to +3.5 cm Vertical: 0 to 5.0 cm Needle: 0 to 10.0 cm
Biopsy control module	Color 1024 x 600 pixel resolution touch screen

Acquisition Workstation

Connectivity	
DICOM services	Print, query, storage, storage commitment, worklist
Integration profile: Scheduled workflow	Actor: Acquisition modality
	<ul style="list-style-type: none"> Option: Assisted acquisition protocol setting Option: PPS exception management Option: Broad worklist query Option: Patient-based worklist query
Integration profile: Patient information reconciliation	Actor: Acquisition modality
	<ul style="list-style-type: none"> Option: None
Integration profile: Access to radiology information	Actor: Image display
	<ul style="list-style-type: none"> Option: None
Integration profile: Portable data for imaging	Actor: Portable media creator
	<ul style="list-style-type: none"> Option: None

Note: Tomosynthesis guided biopsy optional upgrade for 2D configuration.



Technical Dimensions

Figure 1: Gantry and Generator Dimensions

Gantry/Patient Platform Dimensions	
A. Height	107 cm (42 inches)
B. Width	229 cm (90 inches)
C. Depth with C-arm	178 cm (70 inches)
D. Overall Depth	198 cm (78 inches)
Total Weight	445 kg (980 pounds)

Generator Dimensions	
E. Height	63 cm (25 inches)
F. Width	87 cm (34 inches)
G. Depth	55 cm (22 inches)
Total Weight	136 kg (300 pounds)

Figure 1: Gantry and Generator Dimensions

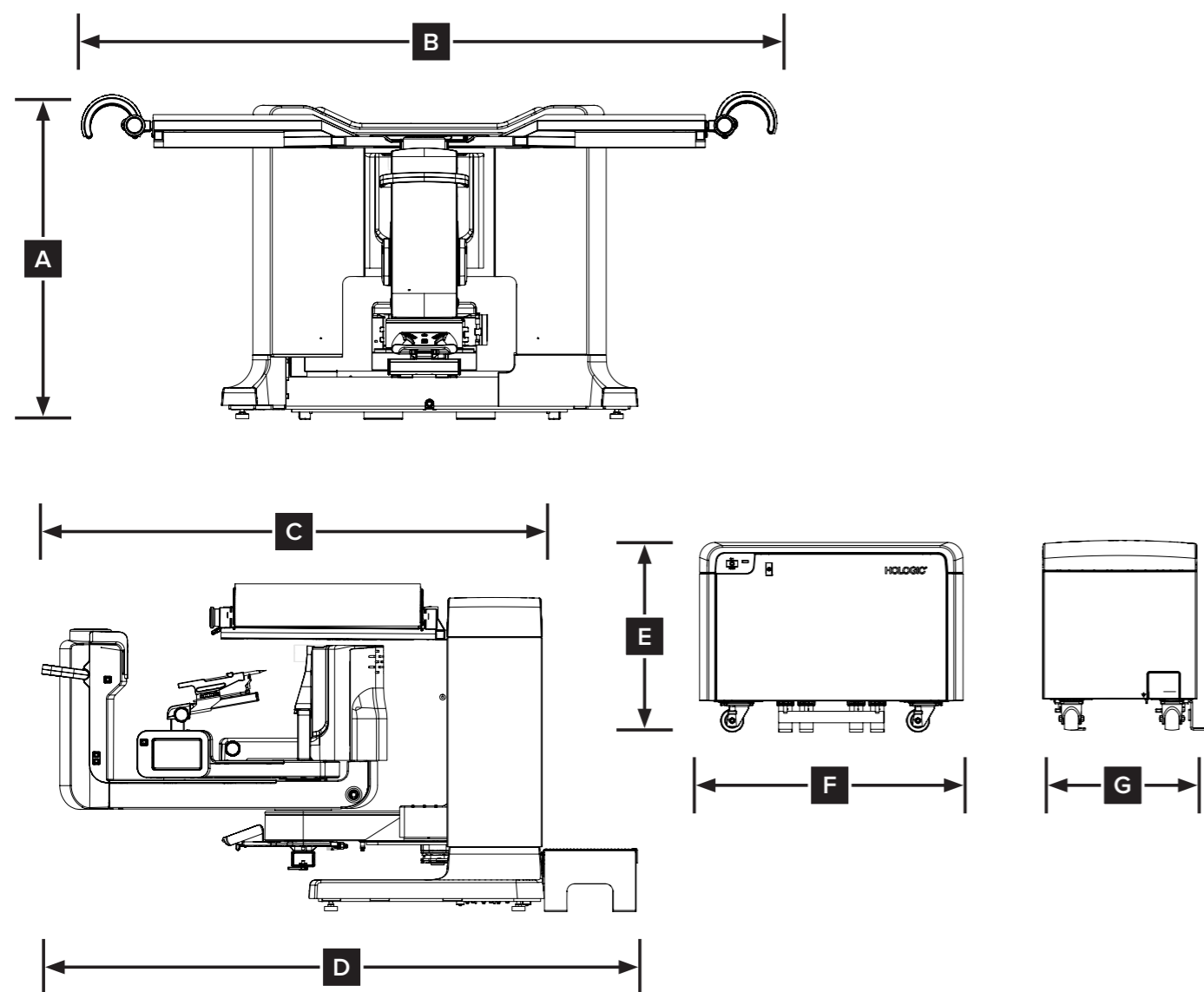
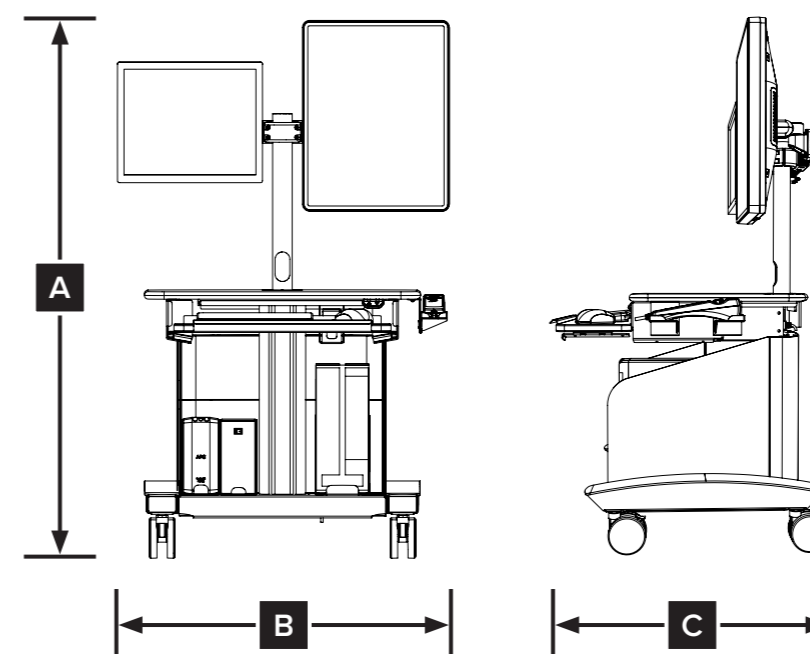

Figure 2: Acquisition Workstation Dimensions

Acquisition Workstation Dimensions	
A. Height	138.4 cm (54.5 inches)
Overall Height Range	138.4 cm (54.5 inches) to 179.1 cm (70.5 inches)
Height Range (floor to work surface)	71.1 cm (28 inches) to 111.8 cm (44 inches)
B. Width	85.4 cm (34 inches)
C. Depth	75.1 cm (30 inches)
Total Weight	114 kg (252 pounds)

Figure 2: Acquisition Workstation Dimensions



Storage Specifications

The Affirm prone biopsy system includes a storage solution to hold the Maximum Comfort package accessories and paddles. Choose between a Storage Cart or Storage Rack depending on the space available in your biopsy suite and your storage needs. Only one storage solution is included with the system purchase.

Storage Cart Specifications

The rolling cart features slots on the outside and hangers on the inside to organize paddles, positioning aids, arm-rest, interchangeable apertures and memory foam cushions.

Dimensions of Storage Cart

Width	Length	Height
18 in (45.7 cm)	51.5 in (130.8 cm)	36.75 in (93.4 cm)



Storage Rack Specifications

The versatile storage rack option includes 5 different racks to store paddles, positioning aids, arm-rest, interchangeable apertures, and memory foam cushions. This space-saving solution mounts on the wall and can be arranged to fit your biopsy suite.

Dimensions of Empty Racks

	Width	Length	Height
Rack for Paddles	28 in (71.1 cm)	4.5 in (11.4 cm)	7 in (17.8 cm)
Rack for Positioning Aids	22 in (55.9 cm)	8 in (20.3 cm)	14 in (36.6 cm)
Rack for Apertures	22 in (55.9 cm)	8 in (20.3 cm)	14 in (36.6 cm)
Rack for Center Pads	22 in (55.9 cm)	6.75 in (17.1 cm)	14 in (36.6 cm)
Rack for Arm-Through Accessories	22 in (55.9 cm)	5.5 in (14.0 cm)	7 in (17.8 cm)



Dimensions of Racks and Accessories

	Width	Length	Height
Rack for Paddles, with 4 Paddles*	28 in (71.1 cm)	4.5 in (11.4 cm)	9.5 in (24.1 cm)
Rack for Positioning Aids, with 5 Pillows*	28 in (71.1 cm)	8 in (20.3 cm)	26.5 in (67.3 cm)
Rack for Apertures, with 3 Apertures*	22 in (55.9 cm)	8 in (20.3 cm)	18.5 in (47.0 cm)
Rack for Center Pads, with 4 Pads	36 in (91.5 cm)	8 in (20.3 cm)	44 in (111.8 cm)
Rack for Arm-Through Accessories, with Arm Rest	22 in (55.9 cm)	5.5 in (14.0 cm)	18.5 in (47.0 cm)

*Leave additional clearance space to remove accessories when installing racks over each other



Purpose. Passion. Promise.

At Hologic, we deliver trailblazing technologies to keep you on the forefront of breast care. Our passion drives us in the relentless pursuit of innovative tools that set new paradigms for the early detection, accurate diagnosis, intervention and treatment of breast cancer — technologies to help you protect and preserve the lives of your patients. With you, we are on a mission to help women live longer, healthier lives.

For more information on the Hologic family of breast health solutions, please visit [hologic.com](https://www.hologic.com).

Contact your Hologic representative to learn more about this next-generation solution.

Breast & Skeletal Solutions | www.hologic.com | euinfo@hologic.com