

MAN-11714-001 Combined PDF consists of:



- Ninety Eight pages 8.5-inch x 11-inch graphics attached.

Artwork master disk contains the following file(s):

File Name	Description
MAN-11714-001_001_01.pdf	Source File
MAN-11714-001_001_02.docx	Signature File

Artwork prints in 4 Color.

Die line shown on artwork is for position only and does not print.

REV AUTHORED BY R. DENTON	DATE 09/17/24	 	
REV DRAFTED BY R. DENTON	DATE 09/17/24		
PROPRIETARY: This document contains proprietary data of Hologic, Inc. No disclosure, reproduction or use of any part thereof may be made except by written permission from Hologic.	TITLE OPERATOR'S MANUAL (IFU), FLUENT PRO, EN GEN 2.0	DOCUMENT NUMBER MAN-11714-001	REV 001
REV. RELEASE DATE: 9/27/2024		SIZE A	SHEET 1 OF 1

HOLOGIC®

# Fluent<sup>®</sup>Pro

Fluid Management System

## Operator's Manual





HOLOGIC®

**Fluent® Pro**

Fluid Management System

Operator's Manual

English



This page is intentionally left blank

# Fluent Pro Fluid Management System

## OPERATOR'S MANUAL

### Contents

<b>1</b>	<b>INTRODUCTION TO SYSTEM, WARNINGS AND PRECAUTIONS</b>	<b>1</b>
<b>1.1</b>	<b>IMPORTANT OPERATOR/USER NOTES</b>	<b>1</b>
1.1.1	TRADEMARK NOTICE	1
1.1.2	MANUFACTURER	1
1.1.3	INDICATIONS FOR USE	1
1.1.4	INTENDED USERS	1
1.1.5	INTENDED USE ENVIRONMENT	1
1.1.6	PATIENT TARGET GROUP	1
1.1.7	CONTRAINDICATIONS	1
1.1.8	IMPORTANT USER NOTES	1
1.1.9	ESSENTIAL PERFORMANCE	2
<b>1.2</b>	<b>WARNINGS AND PRECAUTIONS</b>	<b>2</b>
1.2.1	DEFINITIONS	2
1.2.2	LIST OF WARNINGS AND PRECAUTIONS	2
<b>1.3</b>	<b>SYSTEM INTRODUCTION</b>	<b>3</b>
1.3.1	INTRODUCTION TO THE FLUENT PRO FLUID MANAGEMENT SYSTEM	3
1.3.2	SHIPPING CONTENTS	4
1.3.3	SYSTEM COMPONENTS	4
1.3.4	FLUENT PRO PROCEDURE KIT COMPONENTS	11
<b>2</b>	<b>PROCEDURE SETUP</b>	<b>15</b>
<b>2.1</b>	<b>MOVING THE SYSTEM</b>	<b>15</b>
<b>2.2</b>	<b>POSITIONING THE SYSTEM</b>	<b>15</b>
<b>2.3</b>	<b>CONNECTING THE POWER CORD</b>	<b>16</b>
<b>2.4</b>	<b>LOCKING THE WHEELS</b>	<b>16</b>
<b>2.5</b>	<b>TURNING ON THE FLUENT PRO FLUID MANAGEMENT SYSTEM</b>	<b>17</b>
<b>2.6</b>	<b>CONFIGURE SYSTEM SETTINGS (REQUIRED FOR INITIAL SETUP)</b>	<b>17</b>
<b>2.7</b>	<b>SETUP SYSTEM</b>	<b>18</b>
2.7.1	SETUP SCREEN	18
2.7.2	HANG FLUID BAG	19
2.7.3	UNPACK THE FLUENT PRO PROCEDURE KIT	19
2.7.4	HANG WASTE BAG	21
2.7.5	INSTALL IN-FLOPAK	22
2.7.6	INSTALL OUT-FLOPAK	23
2.7.7	PRIMING THE SYSTEM	26
2.7.8	PRIMING PAUSE	29
2.7.9	HOW TO REPRIME	31
2.7.10	CONNECTING THE MYOSURE TISSUE DEVICE (TRD)	31

<b>3</b>	<b>DURING PROCEDURE</b>	<b>35</b>
3.1	ADJUSTING THE DEFICIT LIMIT .....	35
3.2	ZEROING THE DEFICIT .....	36
3.3	ADJUSTING THE INTRAUTERINE PRESSURE .....	36
3.4	ADJUSTING THE SUCTION SETTINGS .....	37
3.5	PERFORMING THE PROCEDURE .....	37
3.6	ENDING THE PROCEDURE .....	40
3.7	LAST PROCEDURE DATA .....	41
3.8	REPLACING COMPONENTS.....	42
3.8.1	ADDING THE FLUID BAG .....	42
3.8.2	REPLACING THE WASTE BAG .....	43
3.8.3	REPLACING THE TISSUE TRAP.....	45
<b>4</b>	<b>AFTER PROCEDURE</b>	<b>49</b>
4.1	DISASSEMBLY AND DISPOSAL .....	49
4.1.1	BREAKDOWN MYOSURE TISSUE REMOVAL DEVICE (TRD) .....	49
4.1.2	COLLECT PATHOLOGY .....	49
4.1.3	DISPOSE OF WASTE MATERIALS .....	50
4.1.4	DISASSEMBLE THE UNDER-BUTTOCKS DRAPE (UBD) .....	51
4.1.5	DISASSEMBLE THE HYSTEROSCOPE .....	51
4.1.6	DISASSEMBLE THE FLUENT PRO IN-FLOPAK.....	51
4.1.7	DISASSEMBLE THE FLUENT PRO OUT-FLOPAK.....	52
4.1.8	SHUTDOWN AND DISASSEMBLE THE FLUENT PRO FLUID MANAGEMENT SYSTEM.....	52
4.2	CLEANING THE FLUENT PRO FLUID MANAGEMENT SYSTEM.....	52
4.3	STORING THE SYSTEM.....	52
<b>5</b>	<b>TROUBLESHOOTING</b>	<b>57</b>
5.1	HELP.....	57
5.1.1	HELP SCREEN MENU .....	57
5.1.2	HELP WITH SETUP .....	58
5.1.3	HELP WITH PRIMING .....	58
5.1.4	HELP DURING THE PROCEDURE .....	59
5.1.5	HELP WITH PROCEDURE END .....	59
5.2	RESUME PROCEDURE (AFTER POWER LOSS OR SHUTDOWN).....	60
5.3	TROUBLESHOOTING .....	60
5.3.1	FLOPAKS NOT DETECTED .....	60
5.3.2	LOSS OF SUCTION .....	60
5.3.3	INADEQUATE SUCTION.....	60
5.3.4	POOR VISIBILITY .....	61
5.3.5	POOR UTERINE DISTENSION .....	61
5.3.6	TISSUE RESECTION DIFFICULTY .....	61
5.3.7	FLUID DEFICIT DIFFICULTY .....	61
5.3.8	POWER LOSS.....	61
5.3.9	SYSTEM FROZEN .....	62
5.3.10	GUI NOTIFICATIONS AND ALERTS .....	63

<b>6.1</b>	<b>ANNUAL INSPECTION .....</b>	<b>69</b>
6.1.1	SCALE CALIBRATION CHECK.....	69
6.1.2	PRESSURE CALIBRATION CHECK .....	72
<b>6.2</b>	<b>TECHNICAL SPECIFICATIONS .....</b>	<b>75</b>
<b>6.3</b>	<b>POWER CORD SAFETY.....</b>	<b>76</b>
<b>6.4</b>	<b>ELECTROMAGNETIC COMPATIBILITY .....</b>	<b>76</b>
6.4.1	ELECTROMAGNETIC EMISSIONS GUIDANCE AND MANUFACTURER'S DECLARATION.....	76
6.4.2	ELECTROMAGNETIC IMMUNITY GUIDANCE AND MANUFACTURER'S DECLARATION .....	77
6.4.3	RECOMMENDED SEPARATION DISTANCES.....	79
<b>6.5</b>	<b>CONSOLE DISPOSAL .....</b>	<b>80</b>
<b>6.6</b>	<b>PROCEDURE KIT STORAGE .....</b>	<b>80</b>
<b>6.7</b>	<b>PROCEDURE KIT DISPOSAL .....</b>	<b>80</b>
<b>6.8</b>	<b>DISPOSABLES AND ACCESSORIES .....</b>	<b>80</b>
<b>6.9</b>	<b>SERVICE AND WARRANTY INFORMATION .....</b>	<b>81</b>
6.9.1	AUTHORIZED SERVICE TECHNICIAN MAINTENANCE.....	81
6.9.2	WARRANTY INFORMATION .....	81
6.9.3	TECHNICAL SUPPORT AND PRODUCT RETURN INFORMATION .....	81
6.9.4	COMPLAINTS REPORTING: .....	82
6.9.5	CONTACTING HOLOGIC TECHNICAL SUPPORT .....	82
<b>6.10</b>	<b>SYMBOL GLOSSARY .....</b>	<b>82</b>
<b>6.11</b>	<b>GLOSSARY .....</b>	<b>84</b>

## Table of Figures

Figure 1: Front View of System.....	4	Figure 35: Direct Priming Fluid into UBD .....	27
Figure 2: Rear View of System .....	5	Figure 36: Initial Prime Screen.....	28
Figure 3: System Launch Screen.....	6	Figure 37: Air Purge Screen .....	28
Figure 4: System Settings Screen.....	7	Figure 38: Hysteroscope Calibration Screen.....	29
Figure 5: System Setup Screen .....	7	Figure 39: End Priming Screen.....	29
Figure 6: System Confirmation Screen .....	8	Figure 40: Priming Paused Screen.....	30
Figure 7: Procedure Screen.....	8	Figure 41: Priming Complete Screen.....	30
Figure 8: 360° Handle.....	10	Figure 42: Procedure Screen.....	31
Figure 9a: Carton Components.....	11	Figure 43: Reprime Screen .....	31
Figure 9b: Tray Components .....	11	Figure 44: Procedure Screen.....	35
Figure 9c: Waste Bag.....	11	Figure 45: Change Deficit Limit screen .....	36
Figure 10: Unlock Wheels.....	15	Figure 46: Connecting the MyoSure TRD.....	37
Figure 11: Positioning the System .....	15	Figure 47: Change Scope Screen .....	38
Figure 12: Lock Wheels.....	16	Figure 48: Ready to Prime Screen.....	39
Figure 13a: Power Button.....	17	Figure 49: Priming Complete Screen.....	39
Figure 13b: Launch Screen .....	17	Figure 50: Procedure End Confirmation Screen.....	40
Figure 14: Settings Screen.....	17	Figure 51: Recovering Fluid Screen.....	40
Figure 15: Launch Screen .....	18	Figure 52: Last Procedure Data Screen.....	42
Figure 16: Setup Screen.....	18	Figure 53: Remove Waste Bag Connector .....	43
Figure 17: Setup Step Detected Screen.....	19	Figure 54: Screw Waste Bag Cap onto Waste Bag.....	44
Figure 18: Hang Fluid Bag.....	19	Figure 55: Remove Full Waste Bag.....	44
Figure 19a: Carton and Tray.....	20	Figure 56: Install Waste Bag Connector.....	44
Figure 19b: Carton, Tray and Waste Bag .....	20	Figure 57: Open Tissue Trap Canister Lid.....	45
Figure 20: Waste Bag.....	20	Figure 58: Disconnecting the MyoSure TRD .....	49
Figure 21: Peel Back Sterile Cover .....	20	Figure 59: Remove Waste Bag Connector .....	50
Figure 22a: Out-FloPak connections.....	21	Figure 60: Screw Waste Bag Cap onto Waste Bag.....	50
Figure 22b: In-FloPak connections .....	21	Figure 61: Remove Full Waste Bag.....	51
Figure 23: Hang Waste Bag.....	21	Figure 62: Disconnect UBD .....	51
Figure 24a: Depress In-FloPak Lever.....	22	Figure 63: Help Icon Location.....	57
Figure 24b: Slide In-FloPak Over Shaft .....	22	Figure 64: Help Screen Menu.....	57
Figure 25: Clamp Tubing and Spike Fluid Bag .....	22	Figure 65a: Setup Help Menu.....	58
Figure 26a: Depress Out-FloPak Lever .....	23	Figure 65b: Additional Setup Help Menu .....	58
Figure 26b: Slide Out-FloPak over Shaft.....	23	Figure 66: Priming Help Screen .....	58
Figure 27: Connect UBD Suction Connector.....	23	Figure 67: Procedure Running Help Screen.....	59
Figure 28: Connect Waste Bag Connector.....	24	Figure 68: Procedure End Help Screen.....	59
Figure 29: Setup Screen with All Setup Steps Detected.....	24	Figure 69: System Restarted Screen.....	60
Figure 30: Confirmation Screen.....	25	Figure 70: System Fault Screen .....	65
Figure 31: Confirmation Screen with Steps Complete.....	25	Figure 71: Scale Calibration Check Overview Screen.....	69
Figure 32: Initial Prime Screen .....	26	Figure 72: Scale Calibration Check, Part 1 Screen.....	70
Figure 33: Unclamp Fluid Bag .....	26	Figure 73: Scale Calibration Check, Scales Zeroed Screen.....	70
Figure 34: Open Inflow Stopcock and Unclamp Inflow Tubing.....	27	Figure 74: Scale Calibration Check, Part 2 Screen.....	71

Figure 75: Pressure Calibration Check Overview Screen.....72

Figure 76: Pressure Calibration Check Steps, Part 1 .....72

Figure 77: Pressure Calibration Check Steps, Part 2.....73

Figure 78: Begin Purge for Pressure Calibration Check.....73

Figure 79: Stop Purge for Pressure Calibration Check.....74

Figure 80: Performing Pressure Calibration Check ..... 74

Figure 81: Preventative Maintenance Due Date..... 81

**List of Tables**

Table 1: Real-time Display, Notifications and Troubleshooting.....63

Table 2: Real-time Display, Alerts and Troubleshooting .....64

Table 3: Real-time Display, System Faults .....66

Table 4: Technical Specifications.....75

Table 5: Electromagnetic Emissions Guidance .....76

Table 6: Electromagnetic Immunity Guidance.....77

Table 7: Guidance and Manufacturer's Declaration – Electromagnetic Immunity..... 79

Table 8: Recommended Separation Distances ..... 79

Table 9: Disposables and Accessories ..... 80

Table 10: Symbols..... 82

This page is intentionally left blank

# Introduction to System, Warnings and Precautions



This page is intentionally left blank

# 1 Introduction to System, Warnings and Precautions

## 1.1 Important Operator/User Notes

This manual is written for medical personnel who will be responsible for operating the Fluent® Pro Fluid Management System. It is extremely important that the operator read and thoroughly understand the contents of this manual, and follow the instructions contained herein for reliable, safe, and efficient operation of the product.

Rx ONLY (U.S.) - Caution: Federal law restricts this device to sale by or on the order of a physician pursuant to 21 CFR 801.109(b)(1).

### 1.1.1 Trademark Notice

Hologic, Fluent, MyoSure, and associated logos are registered trademarks of Hologic, Inc. and its subsidiaries in the United States and other countries. All other trademarks, registered trademarks, and product names are the property of their respective owners.

### 1.1.2 Manufacturer

HOLOGIC, INC.  
250 Campus Drive,  
Marlborough, MA, 01752 USA  
1.800.442.9892 (US Toll Free)

### 1.1.3 Indications For Use

The Fluent Pro Fluid Management System is intended to provide liquid distension of the uterus during diagnostic and operative hysteroscopy, and to monitor the volume differential between the irrigation liquid flowing into and out of the uterus while providing drive, control, and suction for hysteroscopic morcellators.

### 1.1.4 Intended Users

The gynecologist should be trained in diagnostic and therapeutic hysteroscopy, resection, and removal of gynecological tissue.

### 1.1.5 Intended Use Environment

The Fluent Pro Fluid Management System is designed to be used in operating rooms, ambulatory surgical centers, and physician's office environments.

### 1.1.6 Patient Target Group

The intended patient population for the Fluent Pro Fluid Management System is dependent on the Indications for Use and Contraindications; it is not limited by age, weight, or other health conditions unrelated to hysteroscopic contraindications.

### 1.1.7 Contraindications

- The system may not be used to introduce fluids into the uterus when hysteroscopy is contraindicated. See the operator's manual of your hysteroscope for absolute and relative contraindications.
- The Fluent Pro Fluid Management System should not be used to remove pathologies from pregnant patients or patients exhibiting pelvic infection, cervical malignancies, or previously diagnosed endometrial cancer.

### 1.1.8 Important User Notes

- 1.1.8.1 No modification of this equipment is allowed unless by a Hologic trained professional. Service mode is password protected and is intended for Hologic Trained professionals only.
- 1.1.8.2 Read this manual carefully and become familiar with the operation and function of the Fluent Pro Fluid Management System and the accessories before use during surgical procedures. Non-observance of the instructions listed in this manual can lead to:
  - Life-threatening injuries to the patient.
  - Severe injuries of the surgical team, nursing staff, or service personnel.
  - Damage or malfunction of the system and/or accessories.
- 1.1.8.3 Intrauterine distension can usually be accomplished with pressures in the range of 35-75 mmHg. Unless the systemic blood pressure is excessive, it is seldom necessary to use pressures greater than 75-80 mmHg.

1.1.9 **Essential Performance**

Essential Performance of the Fluent Pro Fluid Management System is to provide fluid irrigation to distend the uterus to set pressure levels, and to provide fluid suction while monitoring fluid use to prevent unacceptable levels of intravasation.

1.2 **Warnings and Precautions**

1.2.1 **Definitions**

1.2.1.1 **Warning**

Warnings indicate risks to the safety of the patient or user. Failure to follow warnings may result in injury to the patient or user.

1.2.1.2 **Caution**

Cautions indicate risks to the equipment. Failure to follow cautions may result in damage to the system or the potential loss of system data.

1.2.2 **List of Warnings and Precautions**

The operating instructions in this guide make the system easier to use, while the recommended maintenance procedures help to ensure optimal performance over years of reliable use. As with any surgical instrument, there are important health and safety considerations. These are listed below and highlighted within the text. In order to meet the IEC 60601 safety standard, the console is equipped with a potential equalization conductor which can be used to bring other equipment into the same electrical potential as the console.

Note: The following warnings and precautions apply only to the Fluent Pro Fluid Management System. For details, warnings, and precautions on using the hysteroscope and tissue removal device with the Fluent Pro fluid Management system, refer to the specific documentation for the device.

1.2.2.1 **List of Warnings**



**WARNING!**

- An air embolism can be the result of air contained in the tubing or connected instrument reaching the patient. Ensure there is always fluid in the Fluid Bag to prevent air from being pumped into the patient.
- To avoid the risk of electric shock, this equipment must only be connected to a supply mains with protective earth.
- Do not prime inside the patient.
- The deficit is the total amount of fluid left in the patient or unaccounted for otherwise. Estimating the fluid volume remaining in the patient is the physician's responsibility.
- There is a risk of distension fluid reaching the circulatory system of the patient's soft tissue by passing through the uterus. This risk can be affected by distention pressure, flow rate, perforation of the uterine cavity and duration of hysteroscopic surgery.
- If a low viscosity liquid distention medium is used, intrauterine instillation exceeding two (2) liters should be followed with great care due to the possibility of fluid overload. If a high viscosity fluid (e. g. Hyskon) is used, the use of more than 500 mL should be followed with great care. See labeling of specific fluid used (e.g. Hyskon) for additional information.
- In rare cases, idiosyncratic reactions, including intravascular coagulopathy and allergic reaction including anaphylaxis may occur while performing hysteroscopy if a liquid distention medium is used. Specifically, idiosyncratic anaphylactoid reactions have been reported when using Hyskon as a distension fluid during hysteroscopy. These should be managed like any allergic reaction.
- Distention of the uterus may lead to a tear of the fallopian tube should there be an obstruction or permanent occlusion. The rupture could lead to distension fluid flowing into the patient's peritoneal cavity, resulting in a fluid overload.
- To avoid fluid overload, closely monitor the volume of distending fluid flowing into and out of the patient at all times. Fluid overload is associated with a risk of developing:
  - Hyponatremia with its attending sequelae.
  - Pulmonary edema resulting from fluid overload with isotonic fluids.
  - Cerebral edema resulting from fluid overload and electrolyte disturbances with hyperosmolar (nonionic) fluids such as glycine 1.5% and sorbitol 3.0%.

- Ensure the patient’s body temperature is monitored throughout the entire surgery. Continuous flow of distention fluids during hysteroscopic surgery can lead to a lowering of the patient’s body temperature. Low body temperatures can cause coronary and cardiovascular problems. Longer operating times and the use of cold distension media should be avoided.
- For your own safety and that of your patient, use only Fluent Pro accessories referenced in Table 9: Disposables and Accessories.
- The system is not explosion-proof. Do not use in an area where flammable anesthetic gases are present.
- If a system defect is suspected or confirmed, do not use the system. Ensure the system is fully functional as described in Section 6.1, Annual Inspection.
- Fluent Pro Procedure Kits are single use disposables. Do not re-use or reprocess any of the components contained within the single-use Procedure Kit.

1.2.2.2 **List of Precautions**



**Caution!**

- Do not sterilize or immerse the Fluent Pro Fluid Management System in disinfectant.
- Electrical safety testing should be performed by a biomedical engineer or other qualified person.
- The Fluent Pro Fluid Management System requires special precautions regarding electromagnetic safety and needs to be installed and put into service according to the electromagnetic safety information provided in this manual.
- Portable and mobile RF communications equipment, including cellular telephones and other wireless devices, can affect medical electrical equipment. To avoid damage to or malfunction of the system, do not operate communications equipment or cellular telephones at a distance closer than specified in Section 6.4 Electromagnetic Compatibility.
- Use of the Fluent Pro Fluid Management System adjacent to or stacked with other equipment should be avoided because it could result in improper operation. If such use is necessary, the Fluent Pro Fluid Management System and the other equipment should be observed for proper operation before performing a procedure.
- This equipment is designed and tested to minimize interference with other electrical equipment. However, if interference occurs with other equipment, it may be corrected by one or more of the following measures:
  - Reorient or relocate this equipment, the other equipment, or both.
  - Increase the separation between the pieces of equipment.
  - Connect the pieces of equipment into different outlets or circuits.
  - Consult a biomedical engineer.

**1.3 System Introduction**

1.3.1 **Introduction to the Fluent Pro Fluid Management System**

The Fluent Pro Fluid Management System is designed to provide liquid distension of the uterus during diagnostic and operative hysteroscopy while monitoring the volume differentials between fluid flowing into and out of the uterus. Additionally, the Fluent Pro Fluid Management System supports the use of the MyoSure® tissue removal devices for tissue removal.

1.3.1.1 **Technical Application Scope of the System**

The Fluent Pro Fluid Management System allows Intrauterine Pressure to be adjusted between 40 and 150 mmHg. The system inflow rates will automatically adjust to reach and maintain the preset Intrauterine Pressure setting while the system outflow rates are adjusted by the user through preset suction settings. The system has been designed to provide both fluid and vacuum systems that maximize the performance of the MyoSure Tissue Removal Device. The system provides varying levels of fluid suction.

1.3.1.2 **Suggested Distension Media**

The Fluent Pro Fluid Management System should only be used with sterile media. The Fluent Pro Fluid Management System can be used with hypotonic, electrolyte-free media (e.g., glycine 1.5% and sorbitol 3.0%) and isotonic, electrolyte containing media (e.g., saline 0.9% and Lactated Ringer’s). See “List of Warnings,” Section 1.2.2.1, for risks related to viscosity and the use of a high viscosity media such as Hyskon.

1.3.1.3 **Pressure Measuring and Regulating**

The system operates with a non-contact pressure measurement of the distension medium. The pressure control circuit continuously compares the desired preset Intrauterine Pressure with the actual Intrauterine Pressure. The function of this algorithm is to maintain the preset Intrauterine Pressure. Estimated Intrauterine Pressure can be retrieved from the top right corner of the system display.

1.3.2 **Shipping Contents**

1.3.2.1 The shipping crate contains the Fluent Pro Fluid Management System console and a shipping box with the Fluent Pro Fluid Management System components.

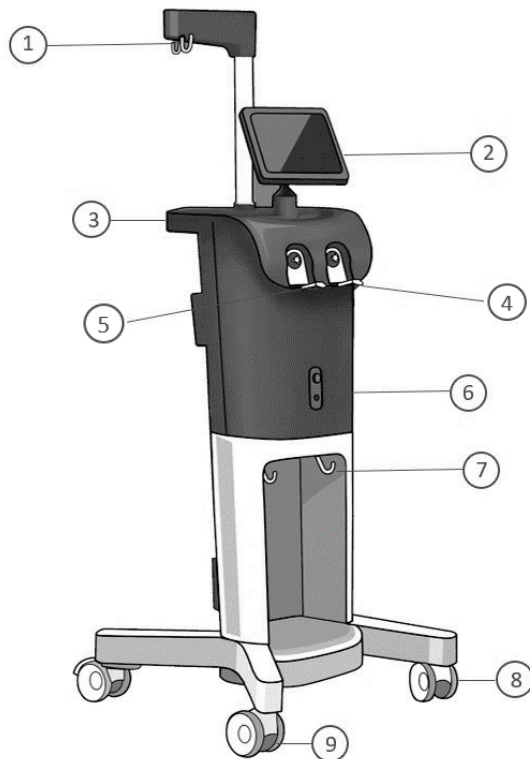
1.3.2.2 The following components are contained in the Fluent Pro Fluid Management System shipping box:

- Foot Pedal: Controls MyoSure tissue removal device (TRD) operation.
- Power Cord: Establishes an electrical connection between the Fluent Pro Fluid Management System and a wall outlet.
- Fluent Pro Fluid Management System Operator’s Manual: Manual that describes how to use the Fluent Pro Fluid Management System.
- Fluent Pro Fluid Management System User Reference Card: One sheet that highlights how to use the Fluent Pro Fluid Management System.
- A 500 g weight for completing the Scale Calibration Check.

For a list of components not included in the shipping crate, reference Table 9: Disposables and Accessories.

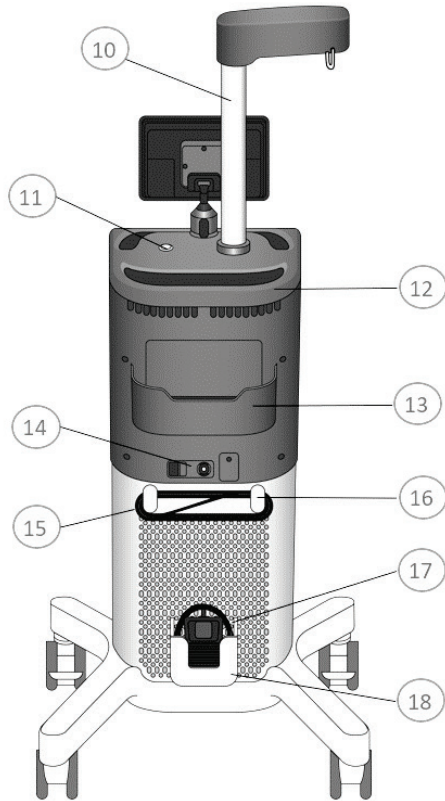
1.3.3 **System Components**

Figure 1: Front View of System



System Components (Front View)	
①	Fluid Bag Hooks
②	Touchscreen Monitor
③	Handle
④	Out-FloPak Lever
⑤	In-FloPak Lever
⑥	MyoSure TRD Panel
⑦	Waste Bag Hooks
⑧	Wheel
⑨	Wheel Lock

Figure 2: Rear View of System



System Components (Rear View)	
10	IV Pole
11	Power Button
12	Handle
13	Accessory Basket
14	Power Cord Port
15	Power Cord
16	Cord Wrap
17	Foot Pedal
18	Foot Pedal Basket

### 1.3.3.1 Fluid Bag Hooks

Fluid Bags (not included) containing hypotonic, isotonic, ionic and non-ionic distention fluids hang from the Fluid Bag Hooks located on the IV pole at the top of the Fluent Pro Fluid Management System. Each Fluid Bag Hook can support up to three (3) liters of fluid. Hang only a single Fluid Bag on the Fluid Bag Hooks at a time. The In-FloPak™ contains a bag spike which connects the In-FloPak to the Fluid Bag. Fluid is pulled from the Fluid Bag through the In-FloPak and delivered through the hysteroscope inflow channel into the patient.



**WARNING!**

Do not place excessive force or weight on the Fluid Bag Hooks. Doing so may result in an inaccurate fluid deficit value, causing risk to patient safety.



**WARNING!**

When performing monopolar hysteroscopic electrosurgery, the distention medium must be electrically non-conductive. Examples include glycine, sorbitol, and mannitol.



**WARNING!**

When performing bipolar electrosurgical resection procedures, the distention medium may be isotonic. Examples include saline and lactated Ringer's solution.

### 1.3.3.2 Touchscreen Monitor

The Touchscreen Monitor includes two system speakers and the Touchscreen User Interface. Tilt and swivel the monitor for optimal viewing.



**Caution!**

Only use the Handle to move or position the Fluent Pro Fluid Management System. Do not pull or push the system with the IV pole or Touchscreen Monitor.

**1.3.3.2.1 Touchscreen User Interface**

Use the Touchscreen User Interface to configure and view system information, set the deficit limit, prime the system, and make other adjustments as needed. The Touchscreen prompts perform initial setup tasks (such as Hang Fluid Bag) and displays when the task has been completed.

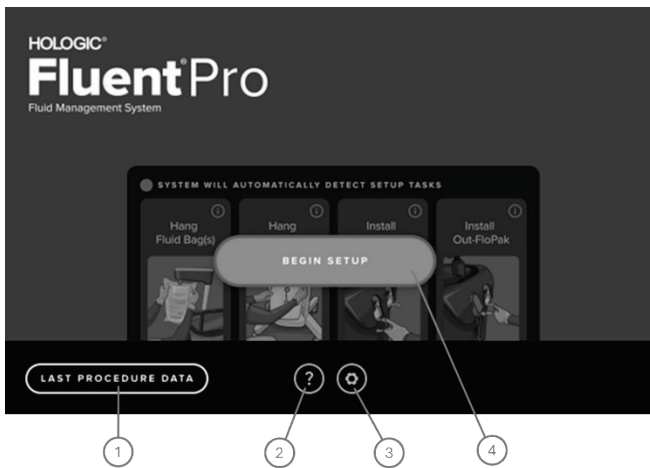
**1.3.3.2.2 Touchscreen Notifications, Alerts and Faults**

The Touchscreen User Interface displays notifications, alerts and faults. The system continues to run when notifications are displayed, pauses when an alert is displayed, and requires a system restart when a fault is displayed. For a list of notifications, and alerts along with troubleshooting refer to Section 5.3.10.

**1.3.3.3 Touchscreen Icons**

**1.3.3.3.1 System Launch Screen**

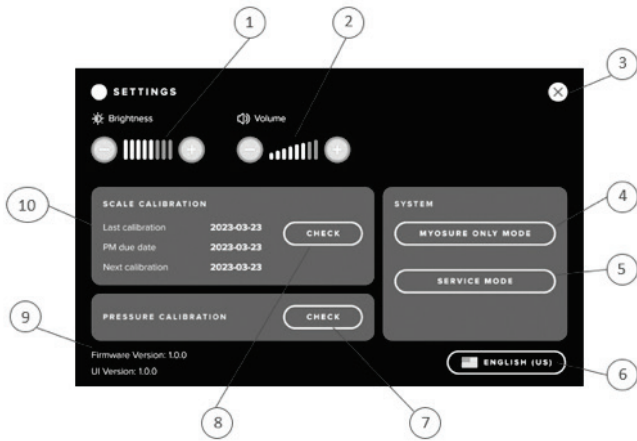
Figure 3: System Launch Screen



System Launch Screen		
Icon	Name	Description
1	Last Procedure Data	Displays the Procedure Data from the last procedure
2	Help	Launches the Help Screen
3	System Settings	Launches the System Settings screen
4	Begin Setup	Launches the System Setup screen to start a new procedure

### 1.3.3.3.2 System Settings Screen

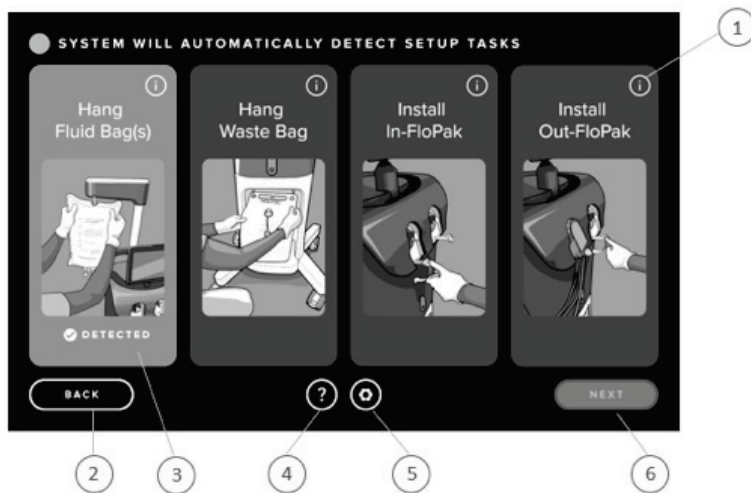
Figure 4: System Settings Screen



System Settings Screen		
Icon	Name	Description
1	Brightness Setting	Increases or decreases brightness setting values
2	Volume Setting	Increases or decreases volume setting values
3	Exit	Closes the displayed screen
4	MyoSure Only Mode	Launches MyoSure Only Mode confirmation screen
5	Service Mode	Launches Service Mode
6	Language	Launches Language selection screen
7	Check	Activates Scale Calibration Check
8	Check	Activates Pressure Calibration Check
9	Firmware and UI Version	Current Firmware Version and UI Version is displayed
10	Scale Calibration Information	Date of Last Calibration, PM due date and Next calibration is displayed

### 1.3.3.3.3 System Setup Screen

Figure 5: System Setup Screen

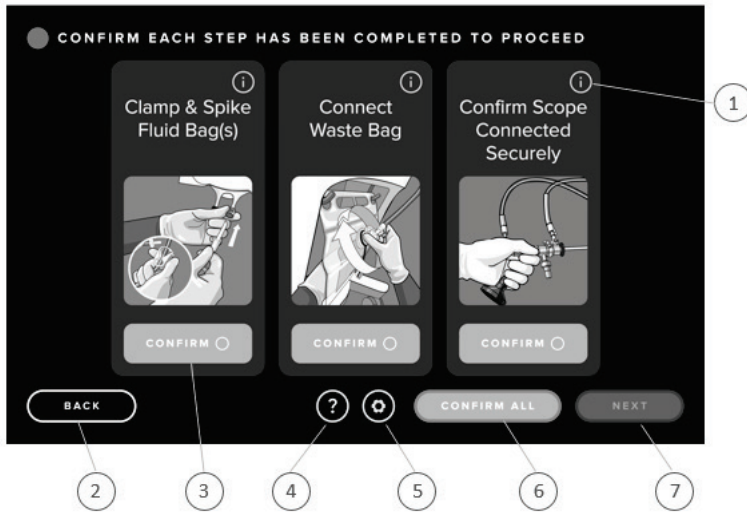


System Setup Screen		
Icon	Name	Description
1	Help	Launches the Help Screen specific to the setup step
2	Back	Displays the previous screen
3	Step Detected	Setup step is complete
4	Help	Launches the Help Screen
5	System Settings	Launches the System Settings screen
6	Next	Launches the next screen



### 1.3.3.3.4 System Confirmation Screen

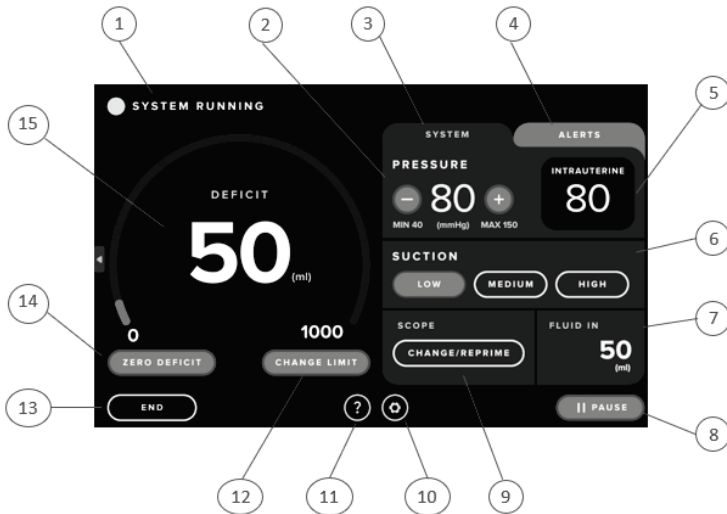
Figure 6: System Confirmation Screen



System Confirmation Screen		
Icon	Name	Description
1	Help	Launches the Help Screen specific to the setup step
2	Back	Displays the previous screen
3	Confirm	Verifies that the required step has been completed
4	Help	Launches the Help Screen
5	System Settings	Launches the System Settings screen
6	Confirm All	Verifies that all required steps have been completed
7	Next	Launches the next screen

### 1.3.3.3.5 Procedure Screen

Figure 7: Procedure Screen



Procedure Screen		
Icon	Name	Description
1	System Status	Displays Status of the system
2	Pressure Setting	Increases or decreases pressure setting values
3	System Panel Tab	Displays Pressure, Suction and Scope Prime settings. Displayed by default.
4	Alerts Panel Tab	Displays Alerts. Becomes active in forefront when an alert event occurs.
5	Intrauterine Pressure Display	Displays actual Intrauterine Pressure.
6	Suction Setting	Sets the suction to Low, Medium or High. Suction level selected is blue.
7	Fluid In Display	Displays total fluid in, including priming volume
8	Pause or Run	When running, pauses the system. When paused, resumes running.
9	Change/Reprime	Displays Reprime and Change Scope icons
10	System Settings	Launches the System Settings screen
11	Help	Launches the Help screen
12	Change Limit	Launches the Change Deficit Limit screen
13	End	Launches Procedure End screen
14	Zero Deficit	Launches the Zero Deficit confirmation screen
15	Deficit Display	Displays the deficit value

1.3.3.4 **In-FloPak Lever**

The In-FloPak Lever is intended to hold the In-FloPak™ in place as well as aid in the release of the In-FloPak during disassembly.

1.3.3.5 **Out-FloPak Lever**

The Out-FloPak Lever is intended to hold the Out-FloPak™ in place as well as aid in the release of the Out-FloPak during disassembly.

1.3.3.6 **MyoSure TRD Panel**

**1.3.3.6.1 MyoSure Tissue Removal Device (TRD) Connector**

The MyoSure tissue removal device (TRD) Connector is located on the Fluent Pro Fluid Management System front panel above the Foot Pedal Connector. For details on operating the Tissue removal device, refer to MyoSure tissue removal device Instructions for Use.

**1.3.3.6.2 Foot Pedal Connector**

The Foot Pedal Connector is located on the Fluent Pro Fluid Management System front panel below the MyoSure tissue removal device (TRD) Connector.

1.3.3.7 **Waste Bag Hooks**

Location to hang the 6L Waste Bag.



**WARNING!**

Do not place excessive force or weight on the Waste Bag Hooks. Doing so may result in an inaccurate fluid deficit value, causing risk to patient safety.

1.3.3.8 **Wheels**

The four wheels located on the bottom of the Fluent Pro Fluid Management System enable movement and positioning of the Fluent Pro Fluid Management System.

1.3.3.9 **Wheel Lock**

A wheel lock is available on each of the four wheels. For details on using the wheel locks, see Instructions provided in Section 2.

1.3.3.10 **Power Button**

The Power button is located on the top of the Fluent Pro Fluid Management System.

1.3.3.11 **IV Pole**

Pole located next to the Touchscreen Monitor that contains two Fluid Bag Hooks.

1.3.3.12 **Power Cord Port**

The Power Cord Port is located on the rear of the Fluent Pro Fluid Management System. The Power Cord attaches to the Power Cord Port. When the system is not in use, wrap the Power Cord around the Cord Wrap on the rear of the system.

1.3.3.13 **Handle**

The 360° Handle is accessible from all directions and allows for the system to be moved easily.

*Figure 8: 360° Handle*



**Caution!**

Only use the Handle to move or position the Fluent Pro Fluid Management System. Do not pull or push the system with the IV pole or Touchscreen Monitor.

1.3.3.14 **Accessory Basket**

The Accessory Basket hangs on the rear of the Fluent Pro Fluid Management System. It is used to store accessories such as Waste Bags, Scope Seals and Tissue Traps. Do not place heavy items in the Accessory Basket. The maximum recommended weight is ten (10) pounds.

1.3.3.15 **Cord Wrap**

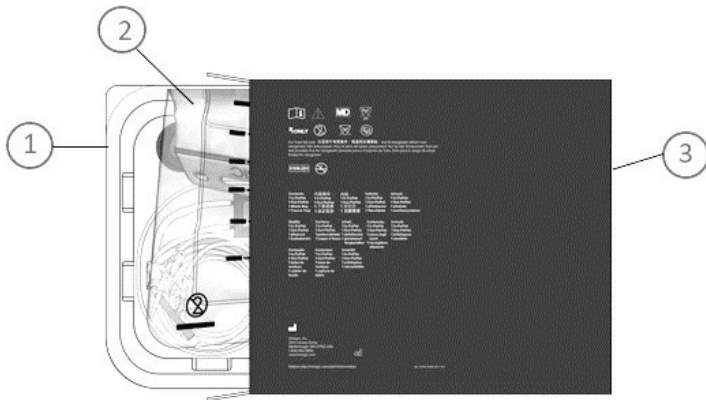
Feature located on the rear of the Fluent Pro Fluid Management System to allow cord to be wrapped and stored when not in use.

1.3.3.16 **Foot Pedal Basket**

The Foot Pedal Basket hangs on the rear of the Fluent Pro Fluid Management System. It is used to store the Foot Pedal when not in use. Do not place heavy items in the Foot Pedal Basket. The maximum recommended weight is 10 pounds.

1.3.4 **Fluent Pro Procedure Kit Components**

Figure 9a: Carton Components



Procedure Kit Components	
①	Procedure Kit Tray
②	Waste Bag
③	Procedure Kit Carton
④	In-FloPak
⑤	Out-FloPak
⑥	Tissue Trap

Figure 9b: Tray Components

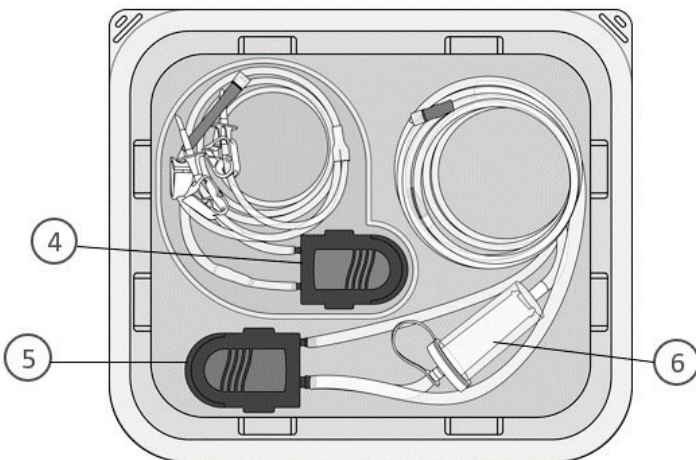


Figure 9c: Waste Bag



**! WARNING!**

Fluent Pro Procedure Kits are single use disposables. Do not re-use or reprocess any of the components contained within the single-use Procedure Kit.

1.3.4.1 **Fluent Pro In-FloPak**

The In-FloPak pulls clean fluid from the Fluid Bag. It contains the Fluid Bag Tube and the hysteroscope Inflow Tube. It fits securely into the blue Fluent Pro In-FloPak Receptacle on the front left side of the fluid management system. These connections allow the transfer of distension fluid from a Fluid Bag to the hysteroscope inflow channel. The flow of fluid is monitored and controlled using the Touchscreen to maintain the pressure at a specified setting.

1.3.4.2 **Fluent Pro Out-FloPak**

The Out-FloPak drains waste fluid from the hysteroscope Outflow Channel, the MyoSure tissue removal device (TRD) Tube, and the Under-Buttocks Drape (UBD) Tube into the Waste Bag. It fits securely into the yellow Fluent Pro Out-FloPak Receptacle on the front right side of the fluid management system. These connections allow the transfer of fluid from the hysteroscope Outflow Channel, the MyoSure tissue removal device (TRD), and the Under-Buttocks Drape (UBD) Port to the Waste Bag.

1.3.4.3 **Tissue Trap**

The Tissue Trap is designed to capture resected tissue throughout the procedure to allow the tissue to be sent to pathology. The Tissue Trap Canister contains the Tissue Trap that captures the resected tissue. Please monitor the Tissue Trap so it does not overflow. For details on handling the Tissue Trap, see Section 3.8.3.

1.3.4.4 **Waste Bag**

The non-sterile Waste Bag is designed to capture waste fluid from hysteroscopic procedures. The Waste Bag hangs on the Waste Bag Hooks at the bottom of the Fluent Pro Fluid Management System. Hang only a single Waste Bag on the Waste Bag Hooks at a time. Hanging more than one bag may impact fluid deficit accuracy. The Waste Bag includes an attached cap. For details on replacing the Waste Bag, see Section 3.8.2.

If an accurate manual deficit assessment is required, pour fluid into calibrated container. The markings on the Waste Bag are not intended as a measuring device, are only for general reference and are not intended as a specific volumetric measuring device.

# Procedure Setup

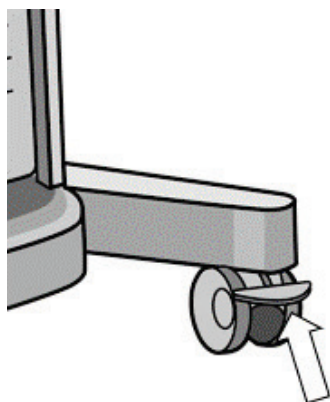
This page is intentionally left blank

## 2 Procedure Setup

### 2.1 Moving the System

- 2.1.1 Before moving the system from one location to another, ensure the system is in transport position:
- 2.1.2 The Power Cord is unplugged from the main outlet and wrapped around the cord wrap on the rear of the system.
- 2.1.3 The Foot Pedal is stored in the Foot Pedal Basket located on rear of the system.
- 2.1.4 To unlock the wheels (if in the locked position), use your foot to lift (upward) the lever on each Wheel Lock.

*Figure 10: Unlock Wheels*

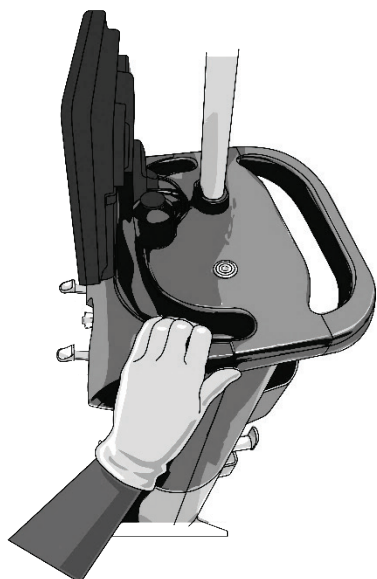


- 2.1.5 No bags are hanging from the Fluid Bag Hooks or Waste Bag Hooks.
- 2.1.6 The Accessory Basket contents weigh less than 10 pounds.

### 2.2 Positioning the System

- 2.2.1 Use the Handle to push, pull, or steer the system.

*Figure 11: Positioning the System*





**! Caution!**

Only use the Handle to move or position the Fluent Pro Fluid Management System. Do not pull or push the system with the IV pole or Touchscreen Monitor.

**! Caution!**

Do not lean on the Handle. Leaning may cause the system to tip.

**! WARNING!**

Do not place excessive force or weight on the Fluid Bag Hooks. Doing so can result in an inaccurate fluid deficit value, causing risk to patient safety.

- 2.2.2 Position the Fluent Pro Fluid Management System to allow the MyoSure tissue removal device (TRD) drive cable to hang in a large arc with no bends, loops, or kinks.
- 2.2.3 The ideal placement of the Fluent Pro Fluid Management System is behind the Physician either to the right (if right-handed) or to the left (if left-handed).
- 2.2.4 Inspect the console for noticeable severe damage. This includes severe damage to the supply arm, supply bag hooks, and waste bag hooks. If severe damage is found discontinue use of the system. To use the device, perform a Scale Calibration Check following steps detailed in Section 6.1.1.

### 2.3 Connecting the Power Cord

- 2.3.1 Unwrap the Power Cord from the Power Cord Wrap on the rear of the Fluent Pro Fluid Management System.
- 2.3.2 Connect the Power Cord to the Power Cord Port on the rear of the Fluent Pro Fluid Management System.
- 2.3.3 Plug the Power Cord directly into a hospital grade wall outlet with the appropriate power for the Fluent Pro Fluid Management System. The Power Button will illuminate orange.
- 2.3.4 Position the Fluent Pro Fluid Management System to ensure that the Power Cord does not obstruct positioning or cause a tripping hazard.

**! WARNING!**

To avoid the risk of electric shock, this equipment must only be connected to a supply mains with protective earth.

**! Caution!**

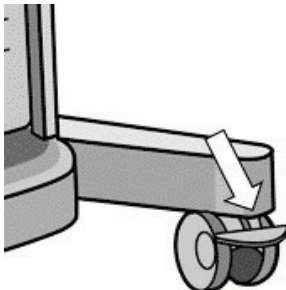
Ensure the available wall outlet voltage matches the data listed on the label attached to the rear of the system. Incorrect voltage can cause errors and malfunctions and may damage the system.

For more information about Power Cord safety, see Section 6.3 Power Cord Safety.

### 2.4 Locking the Wheels

To lock the wheels, use your foot to push down on the outer lever of each Wheel Lock.

Figure 12: Lock Wheels



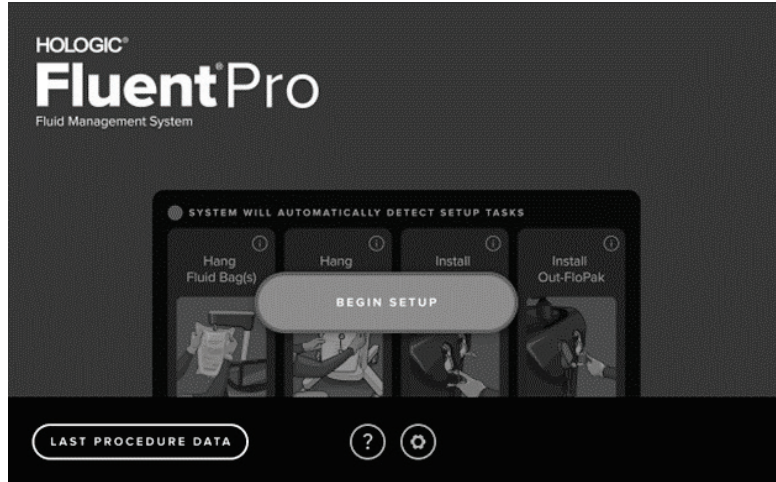
## 2.5 Turning on the Fluent Pro Fluid Management System

Press the Power Button on the top of the system to power on the system. The system performs a setup routine and then displays the System Launch screen. The Power Button will illuminate green when the system is on.

Figure 13a: Power Button



Figure 13b: Launch Screen

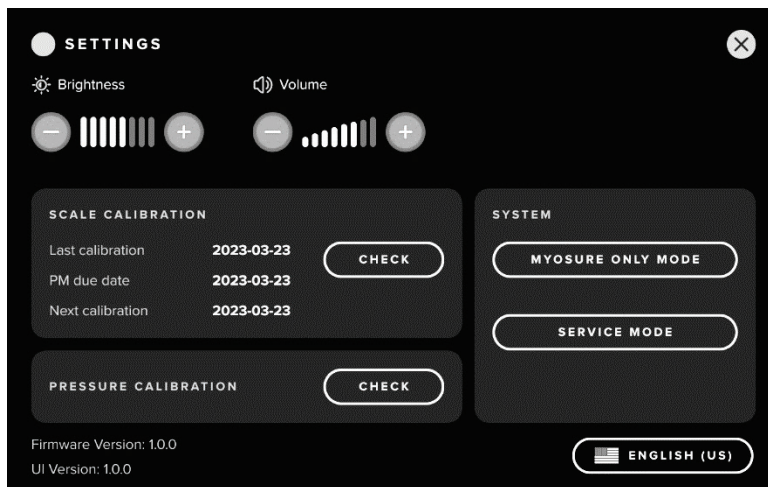


## 2.6 Configure System Settings (Required for Initial Setup)

2.6.1 To configure the system settings, touch the 'SETTINGS' icon. The Settings screen is displayed.

2.6.2 Settings:

Figure 14: Settings Screen



- To choose the display language: Touch the '**LANGUAGE**' icon and select your language.
- To adjust the display brightness: Touch the Down '**(-)**' or Up '**(+)**' icons to increase or decrease brightness.
- To adjust the speaker volume for alerts: Touch the Down '**(-)**' or Up '**(+)**' icons to increase or decrease alert volume.
- To perform Pressure Calibration: Select the Pressure Calibration '**CHECK**' icon to launch the Pressure Calibration check. Refer to Section 6.1.2 for details.
- To perform Scale Calibration: Select Scale Calibration '**CHECK**' icon to launch the Scale Calibration check. Refer to Section 6.1.1 for details.

- To enter MyoSure Only Mode: Touch the **'MYOSURE ONLY MODE'** icon to launch into MyoSure Only Mode. Refer to Section 3.5.5 for details.
- Service Mode: This function is password protected and is intended for Hologic Trained professionals only. To enter Service Mode, touch the **'SERVICE MODE'** icon.

For details on the setup and operation of the hysteroscope, refer to the hysteroscope's Instructions for Use.

## 2.7 Setup System

### 2.7.1 Setup Screen

- 2.7.1.1 From the Launch screen, touch the **'BEGIN SETUP'** icon. The Setup screen is displayed.

Figure 15: Launch Screen

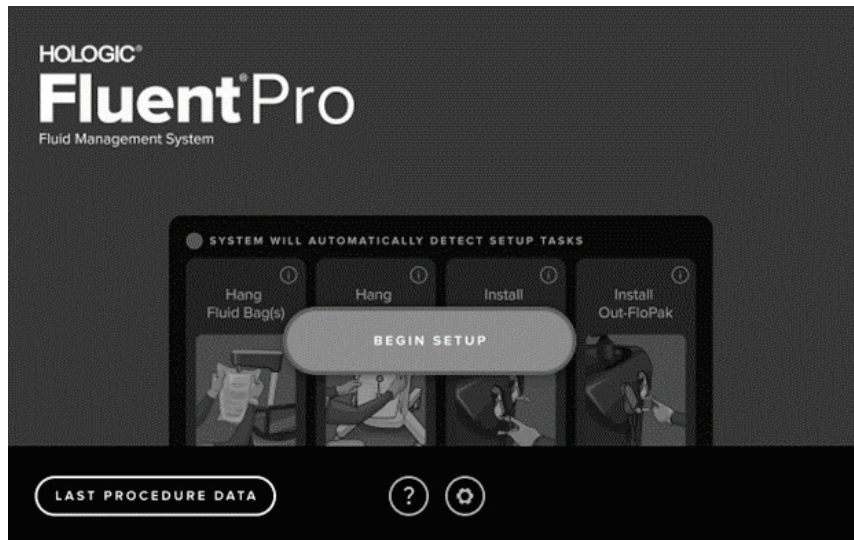
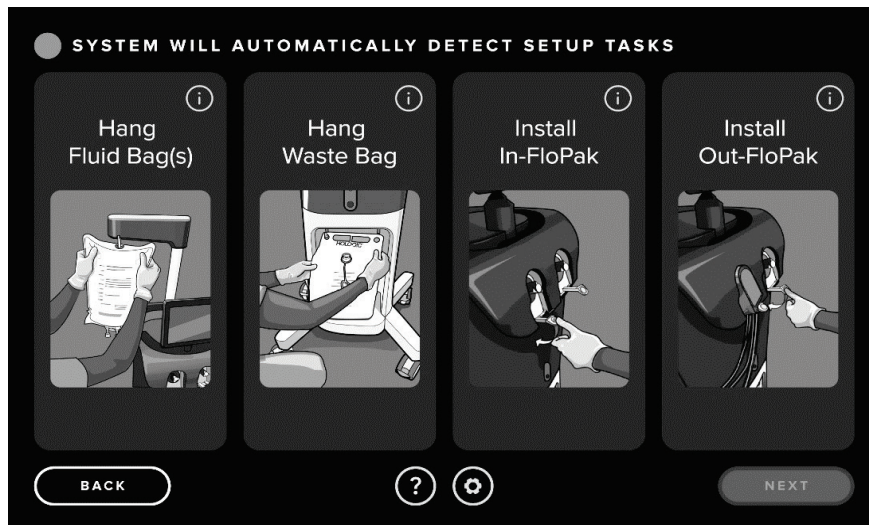
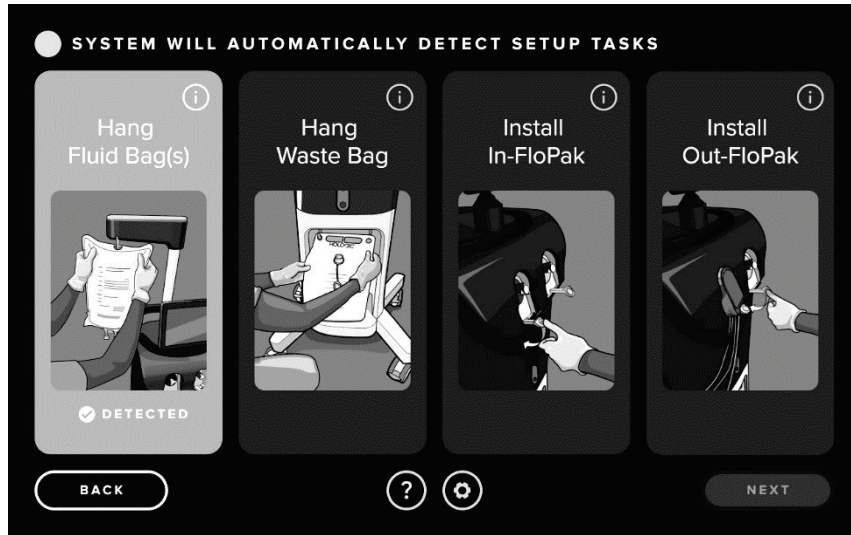


Figure 16: Setup Screen



- 2.7.1.2 Complete the displayed Setup steps. The required steps can be performed in any order.
- 2.7.1.3 Once a step is performed the background will turn from gray to green and a **'✔ DETECTED'** icon will appear.

Figure 17: Setup Step Detected Screen



## 2.7.2 Hang Fluid Bag


- 2.7.2.1 Hang a Fluid Bag containing distension media appropriate for the procedure on the Fluid Bag Hook. Hang only a single Fluid Bag on the Fluid Bag Hooks at a time. The Fluid Bag size should not exceed 3L for each hook. If you need to replace a Fluid Bag during the procedure, see Section 3.8.1.

Figure 18: Hang Fluid Bag



### **WARNING!**

The Fluid Bag size should not exceed 3L per hook. Ensure the Fluid Bag is not resting on top of console. Doing so may impact fluid deficit accuracy.

- 2.7.2.2 The Fluent Pro Fluid Management System does not need to be powered on to hang the Fluid Bags. If the system is on, then follow the prompts. The system will detect and display a ' **DETECTED**' icon on the Setup screen when the Fluid Bag has been properly installed.

## 2.7.3 Unpack the Fluent Pro Procedure Kit

- 2.7.3.1 Open the Fluent Pro Procedure Kit Packaging.



Figure 19a: Carton and Tray

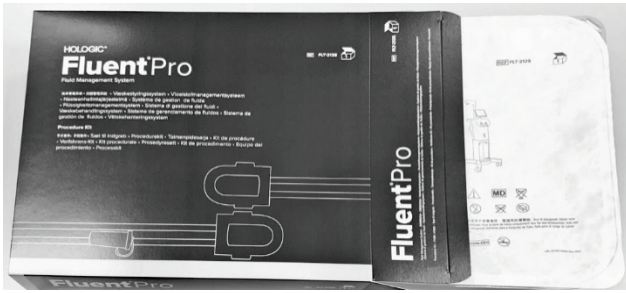
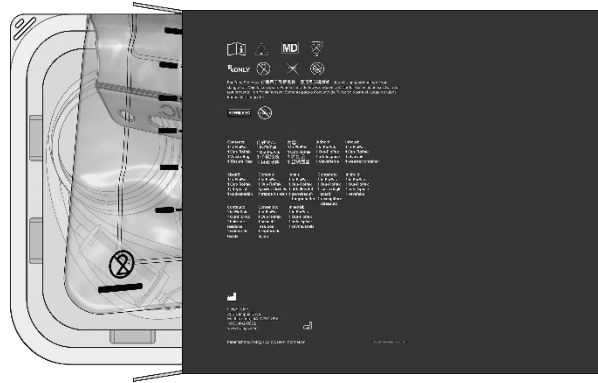
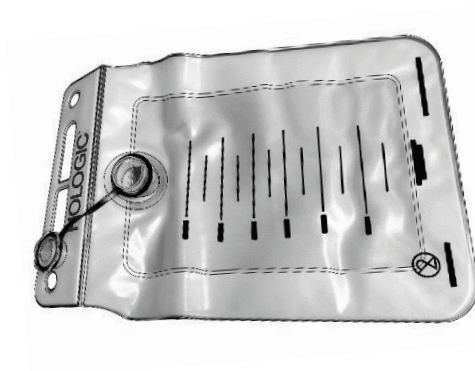


Figure 19b: Carton, Tray and Waste Bag



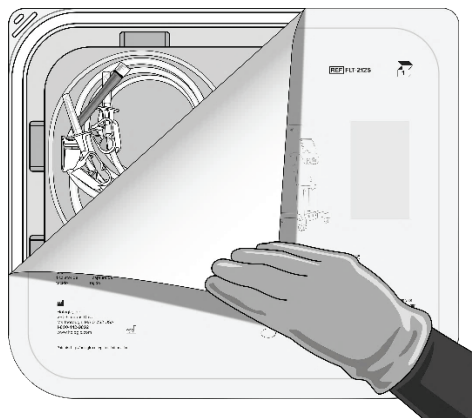
2.7.3.2 Set the non-sterile Waste Bag aside.

Figure 20: Waste Bag



2.7.3.3 Peel back the sterile cover of the Fluent Pro Flo-Pak Kit.

Figure 21: Peel Back Sterile Cover



2.7.3.4 While maintaining sterile technique, place the In-FloPak and Out-FloPak onto a sterile surface.

2.7.3.5 Prior to use, ensure that all FloPak tubing connections are intact.

Figure 22a: Out-FloPak connections

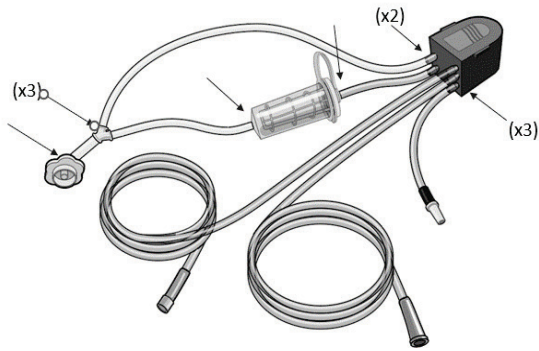
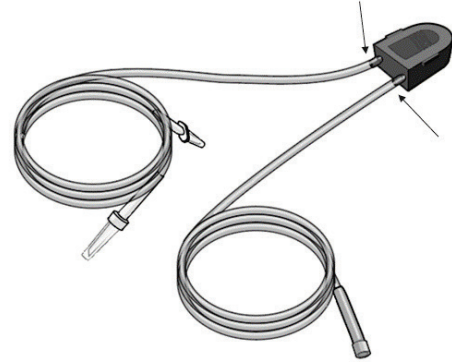


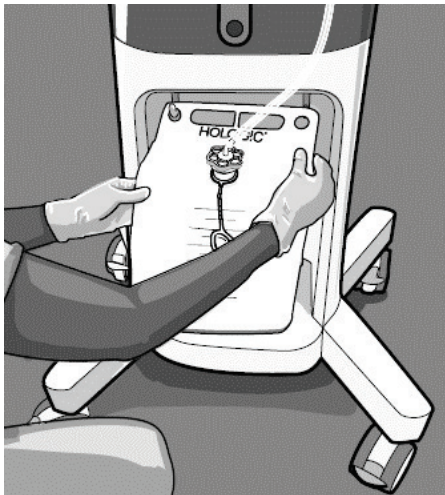
Figure 22b: In-FloPak connections



### 2.7.4 Hang Waste Bag

Hang the new Waste Bag evenly on the Waste Bag Hooks to begin any new procedure. The system will detect and display a '✔ DETECTED' icon on the Setup screen when the Waste Bag has been properly installed.

Figure 23: Hang Waste Bag



**! WARNING!**

Hang only a single Waste Bag on the Waste Bag Hooks at a time. Hanging more than one bag may impact fluid deficit accuracy.

2.7.5 **Install In-FloPak**

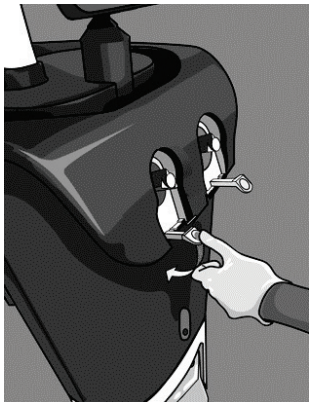


**WARNING!**

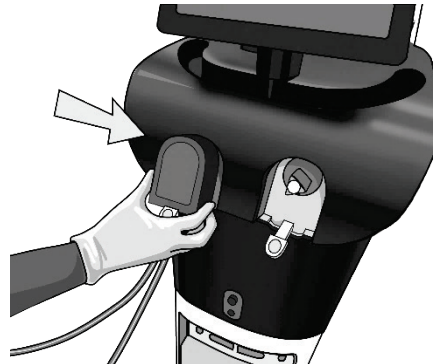
For your own safety and that of your patient, use only Fluent Pro accessories referenced in Table 9: Disposables and Accessories.

- 2.7.5.1 Depress the In-FloPak Lever and slide the In-FloPak over the triangular shaft. While releasing the Lever, ensure the In-FloPak is flush with front of the console. The system will detect and display a '✔ DETECTED' icon on the Setup screen when the In-FloPak has been properly installed.

*Figure 24a: Depress In-FloPak Lever*

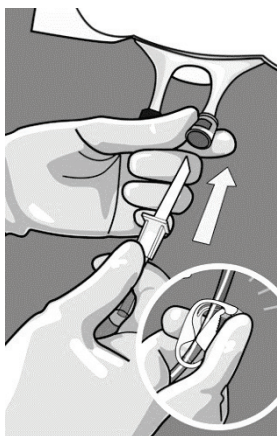


*Figure 24b: Slide In-FloPak Over Shaft*



- 2.7.5.2 Clamp tubing and spike the Fluid Bag.

*Figure 25: Clamp Tubing and Spike Fluid Bag*



- 2.7.5.3 Connect the blue inflow luer connector to the hysteroscope inflow channel.

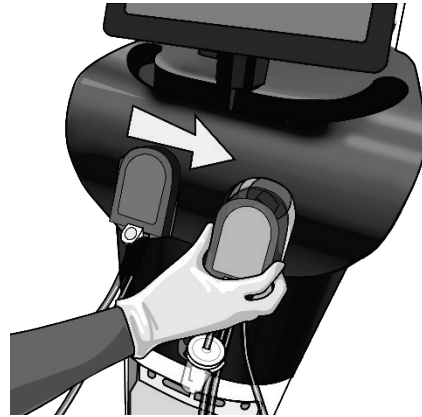
2.7.6 **Install Out-FloPak**

Out-FloPak Lever and slide the Out-FloPak over the triangular shaft. While releasing the Lever, ensure the Out-FloPak is flush with the front of the console. The system will detect and display a '✔ DETECTED' icon on the Setup screen when the Out-FloPak has been properly installed.

Figure 26a: Depress Out-FloPak Lever



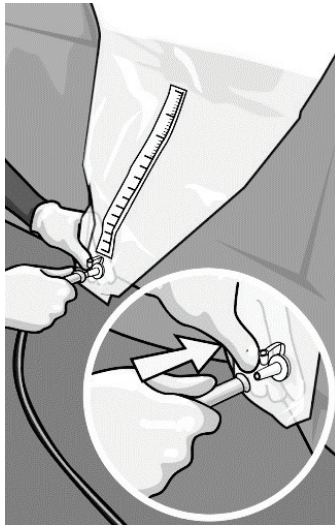
Figure 26b: Slide Out-FloPak over Shaft



2.7.6.1 Connect the yellow outflow luer connector to the hysteroscope Outflow Channel.

2.7.6.2 Connect the yellow suction connector onto the Under-Buttocks Drape (UBD) Port.

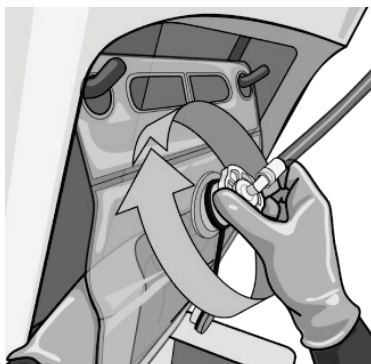
Figure 27: Connect UBD Suction Connector





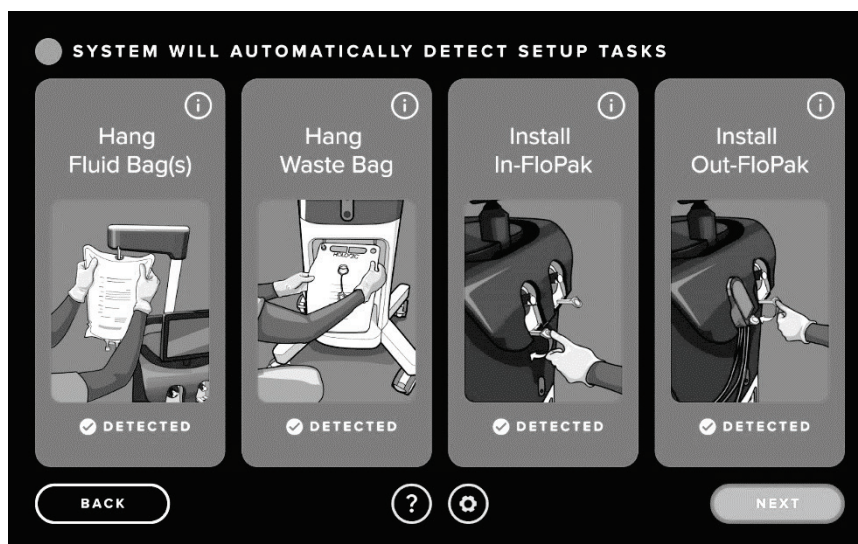
- 2.7.6.3 Secure the Out-FloPak Waste Bag Connector onto the Waste Bag by rotating clockwise.

Figure 28: Connect Waste Bag Connector



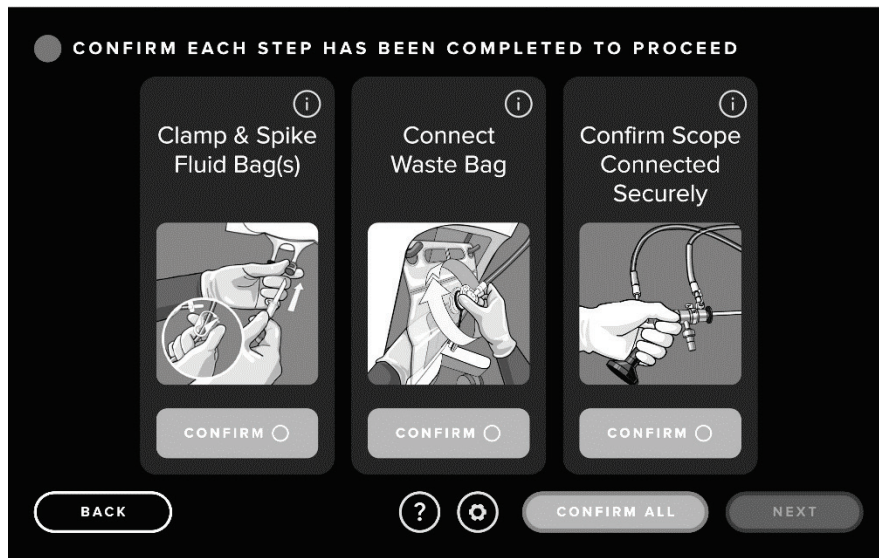
- 2.7.6.4 Connect the light cord and the camera to the hysteroscope.
- 2.7.6.5 Touch **'NEXT'** on the Touchscreen
- 2.7.6.6 Once all displayed steps are complete on the Setup screen, the **'NEXT'** icon will be activated.

Figure 29: Setup Screen with All Setup Steps Detected



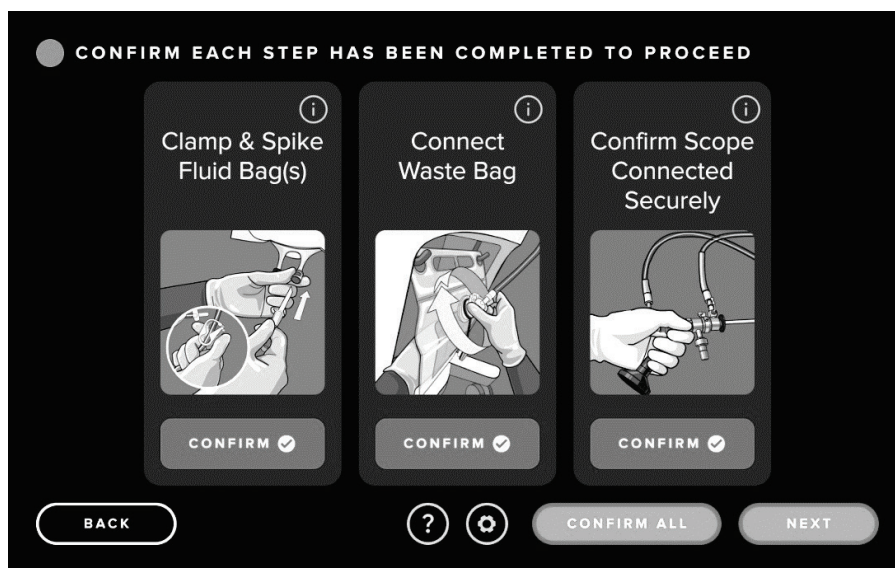
- 2.7.6.7 Touch the **'NEXT'** icon to proceed.
- 2.7.6.8 The Confirmation screen is then displayed.

Figure 30: Confirmation Screen



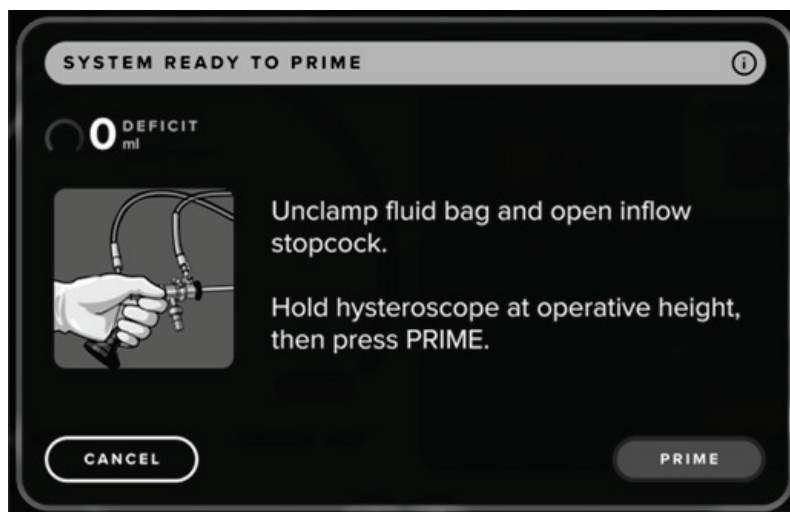
- 2.7.6.9 The displayed steps will not be automatically detected and will need to be manually confirmed by touching the blue **'CONFIRM'** icon. Once a step is confirmed the confirmation icon will turn from blue to green and a **'CONFIRM ✓'** icon will appear. The actions can be confirmed in any order and can be confirmed simultaneously by selecting the **'CONFIRM ALL'** icon.
- 2.7.6.10 Once all steps are confirmed, the **'NEXT'** icon will be illuminated.

Figure 31: Confirmation Screen with Steps Complete



- 2.7.6.11 Touch **'NEXT'** on the Touchscreen.
- 2.7.6.12 The Initial Prime screen is then displayed.

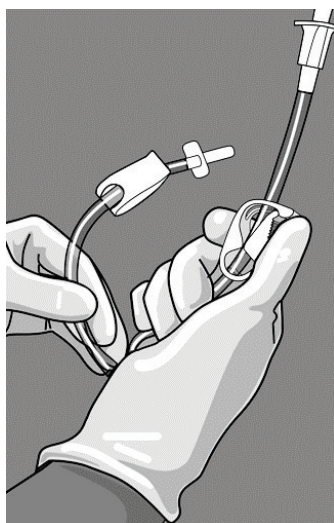
Figure 32: Initial Prime Screen



## 2.7.7 Priming the system

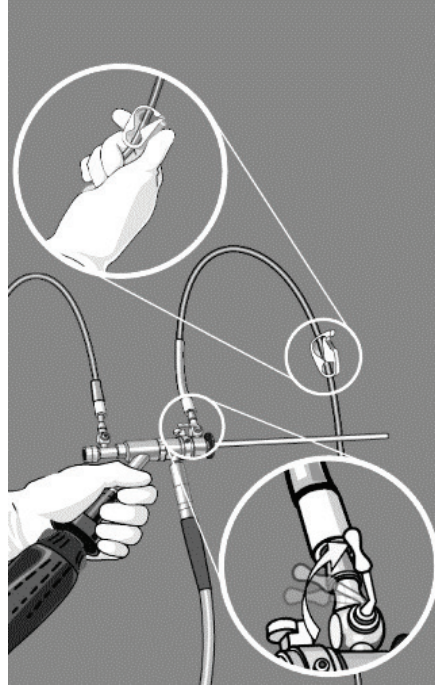
- 2.7.7.1 Begin each procedure with a new, full Fluid Bag. Priming the system runs the pump for approximately one (1) minute to purge air from the tubing and calibrate the hysteroscope.
- 2.7.7.2 Before priming, make sure that the Fluent Pro In-FloPak and Fluent Pro Out-FloPak are properly connected as described in Section 2.7: Setup System.
- 2.7.7.3 The system should be primed at the beginning of a case. Refer to Section 2.7.9 for instructions on how to Reprime the system.
- 2.7.7.4 To prime the system, perform the following steps:
  - 2.7.7.4.1 Unclamp Fluid Bag.

Figure 33: Unclamp Fluid Bag



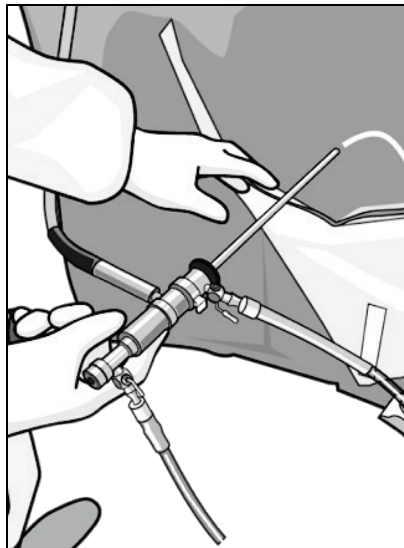
- 2.7.7.4.2 Open the inflow stopcock and unclamp the inflow tubing clamp.

*Figure 34: Open Inflow Stopcock and Unclamp Inflow Tubing*



- 2.7.7.4.3 Direct priming fluid into a basin or Under-Buttocks Drape (UBD).

*Figure 35: Direct Priming Fluid into UBD*



- 2.7.7.4.4 Prime should be performed at the operative height.



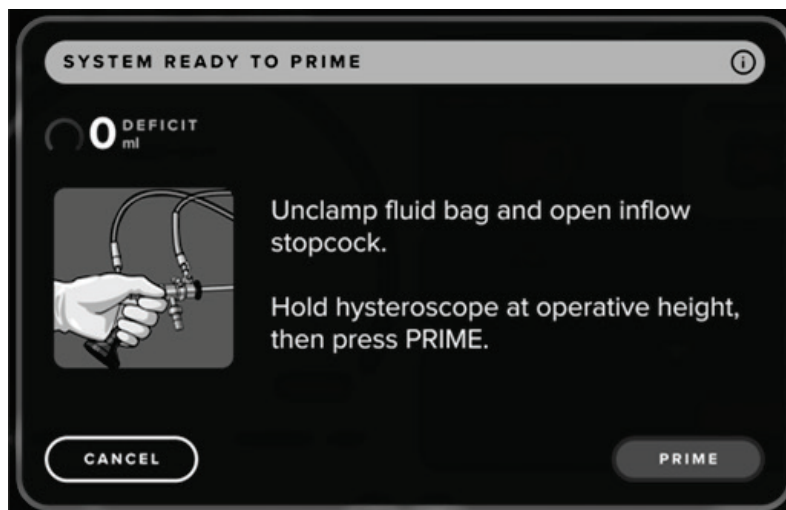
**WARNING!**

Do not prime inside the patient.



- 2.7.7.4.5 Touch the 'PRIME' icon on the Touchscreen.

Figure 36: Initial Prime Screen



- 2.7.7.4.6 The system will perform an air purge and hysteroscope calibration.

Figure 37: Air Purge Screen



Figure 38: Hysteroscope Calibration Screen



## 2.7.8 Priming Pause

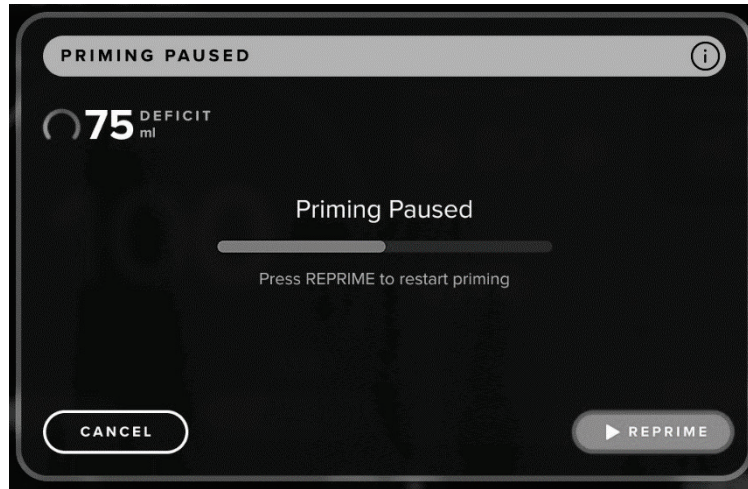
2.7.8.1.1 To stop priming at any time, touch the **'PAUSE'** icon. The End Priming Screen is displayed.

Figure 39: End Priming Screen



- 2.7.8.1.2 To end priming touch 'YES'. To continue priming touch 'NO' to return to the Priming Paused screen.

Figure 40: Priming Paused Screen



- 2.7.8.1.3 To continue priming after pause, press '**REPRIME**'. When priming is resumed after pausing, the system will restart the priming sequence from the beginning.
- 2.7.8.2 When the priming process is complete, the inflow and outflow motors stop, and the Priming Complete screen is displayed.

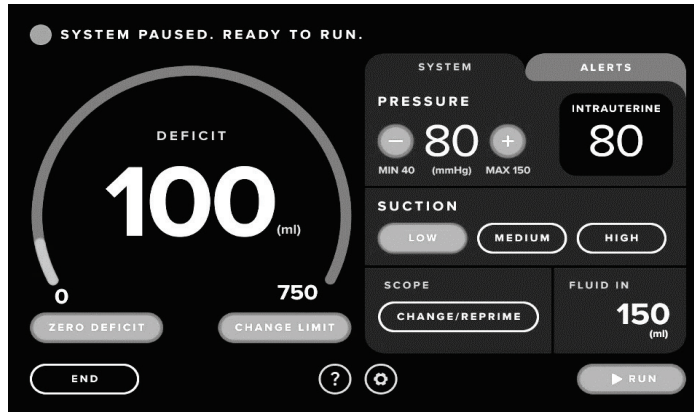
Figure 41: Priming Complete Screen



- 2.7.8.3 If priming was done outside the Under-Buttocks Drape, the fluid deficit needs to be zeroed as a false deficit can ensue. Touch the '**ZERO DEFICIT**' icon and follow the instructions to zero the deficit.
- 2.7.8.4 If priming was done inside the Under-Buttocks Drape, the deficit does not need to be zeroed after priming.

- 2.7.8.5 Select the **'NEXT'** icon. The Procedure screen will be displayed.

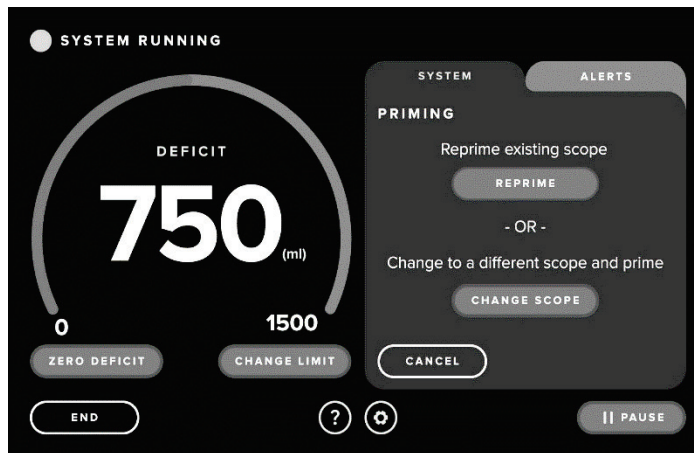
Figure 42: Procedure Screen




## 2.7.9 How to Reprime

- 2.7.9.1 Touch the **'CHANGE/REPRIME'** icon. The system will pause, and the System Tab will display the Reprime and Change Scope Confirmation screen.

Figure 43: Reprime Screen



- 2.7.9.2 Touch the **'REPRIME'** icon. The Reprime screen will appear.
- 2.7.9.3 Direct reprime fluid the Under-Buttocks Drape (UBD).
- 2.7.9.4 Prime should be performed at the operative height.
-  **WARNING!**  
Do not prime inside the patient.
- 2.7.9.5 Follow the prompts and touch the **'PRIME'** icon.
- 2.7.9.6 When the reprime is complete, the Priming Complete screen will be displayed.
- 2.7.9.7 Touch the **'NEXT'** icon to continue.

## 2.7.10 Connecting the MyoSure Tissue Device (TRD)

If setting up the MyoSure TRD, refer to Section 3.5.



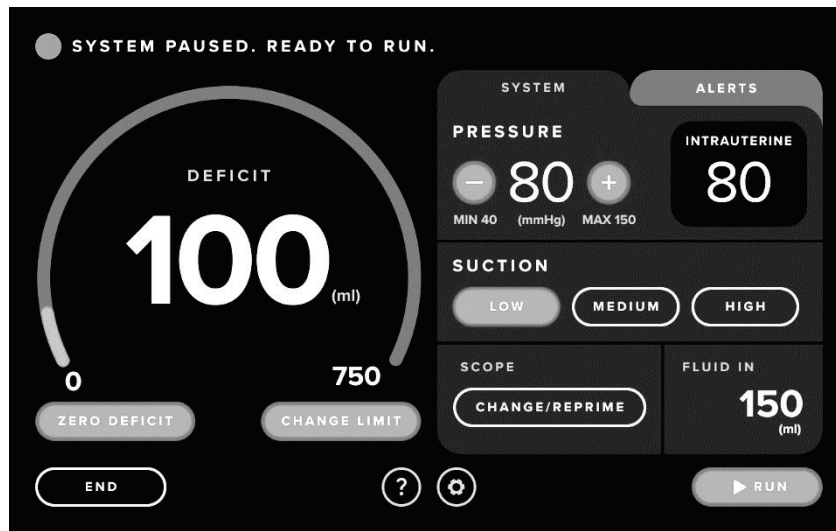
This page is intentionally left blank

During Procedure

This page is intentionally left blank

### 3 During Procedure

Figure 44: Procedure Screen



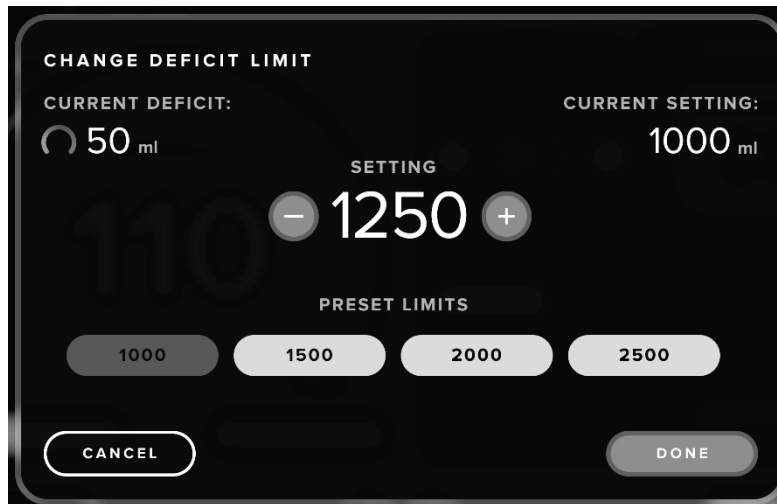
#### 3.1 Adjusting the Deficit Limit

##### 3.1.1 About Deficit Limits

- 3.1.1.1 The deficit is the total amount of fluid left in the patient or unaccounted for otherwise.
- 3.1.1.2 The default Deficit Limit at the start of a new procedure is set to 750 mL.
- 3.1.1.3 Before the procedure has started, the Deficit Limit can be adjusted from 100 mL to 2500 mL in increments of 50 mL.
- 3.1.1.4 Once the procedure has started, the Deficit Limit can be increased beyond 2500 mL, if necessary, at the discretion of the physician. The Fluid In is displayed on the procedure screen in mL and reflects the total fluid in, including priming volume, unless the deficit was zeroed out because system was not primed into the under buttocks drape.

- 3.1.2 Perform the following steps to adjust the Deficit Limit as necessary.
  - 3.1.2.1 Touch the **'CHANGE LIMIT'** icon on the System tab on the Procedure screen.

Figure 45: Change Deficit Limit screen



- 3.1.2.2 To adjust the Deficit Limit in increments of 50 mL, touch the Down ‘(-)’ or Up ‘(+)’ icons.
- 3.1.2.3 To select one of the preset the Deficit Limit options (1000, 1500, 2000, or 2500 mL), touch the desired limit icon.
- 3.1.2.4 Touch the **'DONE'** icon to set the limit and close the Change Deficit Limit screen.

### 3.2 Zeroing the Deficit

Touch the **'ZERO DEFICIT'** icon on the procedure screen to zero the deficit.



**WARNING!**

Zeroing the deficit display should be done at the physician’s discretion.

### 3.3 Adjusting the Intrauterine Pressure

#### 3.3.1 About Intrauterine Pressure

- 3.3.1.1 The default Intrauterine Pressure at the start of a new procedure is 80 mmHg.
- 3.3.1.2 The pressure can be adjusted from 40 mmHg to 150 mmHg in increments of 5 mmHg.
- 3.3.1.3 The actual Intrauterine Pressure is displayed on the top right corner of the procedure screen.

#### 3.3.2 To adjust the pressure:

- 3.3.2.1 Touch the Down ‘(-)’ or Up ‘(+)’ icons to adjust the Pressure setting.



**WARNING!**

The uterine cavity distention pressure should be the lowest pressure necessary to distend the uterine cavity and ideally should be maintained below the mean arterial pressure (MAP).



**WARNING!**

If the deficit is rapidly increasing, or the visualization field does not respond to a change in pressure set point, examine the visual field for injury or a leak from the cervix.

Note: If the deficit rate increases equal to or greater than 300 mL/min a high fluid loss alert will occur. See

troubleshooting in Section 5 for details.

### 3.4 Adjusting the Suction Settings

3.4.1 About Suction Settings for the MyoSure TRD, Outflow Channel and Under-Buttocks Drape (UBD)

3.4.1.1 The default Suction Setting at the start of a new procedure is Low.

3.4.1.2 The suction can be adjusted to Low, Medium or High.

3.4.1.3 The suction can be adjusted at any point when the system is running.

3.4.2 To adjust the suction:

3.4.2.1 Touch the '**LOW**', '**MEDIUM**' or '**HIGH**' icon on the System Running screen.

### 3.5 Performing the Procedure

3.5.1 To Change a Hysteroscope, Refer to Section 3.5.6. To Reprime the Scope, Refer to Section 2.7.9.

3.5.2 Starting the Hysteroscopy procedure.

3.5.2.1 Touch the '**RUN**' icon.

3.5.2.2 Refer to the hysteroscope Instructions for Use for complete instructions on the use and operation of the hysteroscope, including warnings and precautions.

3.5.3 **Connecting the MyoSure Tissue Removal Device (TRD) (when applicable).**

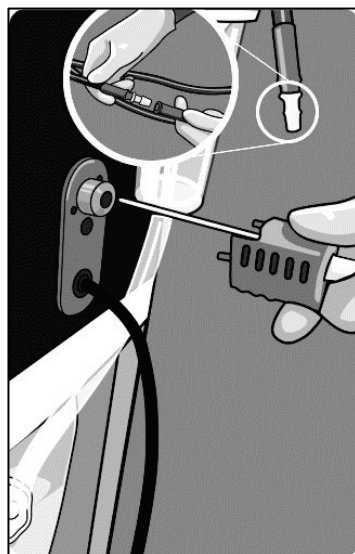
3.5.3.1 MyoSure Tissue Removal Device setup may be performed at any stage of the procedure.

3.5.3.2 Connect the foot pedal tube to the connector on the MyoSure TRD Panel.

3.5.3.3 Connect the MyoSure TRD flexible drive cable into the corresponding connection on the MyoSure TRD panel.

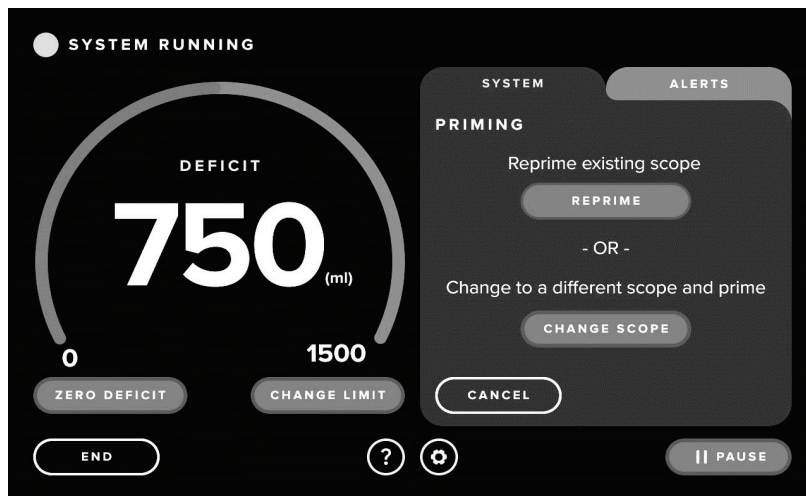
3.5.3.4 Connect the MyoSure TRD suction tube to the tube on the Out-FloPak that has a gray band adjacent to the barb connector.

Figure 46: Connecting the MyoSure TRD



- 3.5.4 Using the MyoSure Tissue Removal Device (TRD) During a Procedure (When Applicable).
  - 3.5.4.1 Introduce the TRD through the working channel of the hysteroscope.
  - 3.5.4.2 After pressing the **'RUN'** icon to start the procedure, press the Foot Pedal to activate the MyoSure TRD cutting blade. Ensure the foot pedal is placed in a location that is accessible to the physician.
  - 3.5.4.3 The MyoSure TRD cannot be operated when the Fluent Pro Fluid Management System is paused.
  - 3.5.4.4 Refer to the MyoSure TRD Instructions for Use for more information on how to use the MyoSure TRD.
- 3.5.5 Using the MyoSure Tissue Removal Device (TRD) in MyoSure Only mode.
  - 3.5.5.1 After entering MyoSure Only mode from the Settings screen, the fluid management system is disabled and only MyoSure control is enabled, and the foot pedal can be used to operate the MyoSure TRD.
  - 3.5.5.2 Refer to the MyoSure tissue removal device Instructions for Use for more information on how to use the MyoSure TRD.
  - 3.5.5.3 To exit MyoSure Only mode select the **'END'** icon and follow the prompts.
- 3.5.6 Changing the Hysteroscope During a Procedure.
  - 3.5.6.1 Touch the **'CHANGE/REPRIME'** icon. The system will pause, and the System tab will display the Reprime and Change Scope Confirmation screen.

Figure 47: Change Scope Screen



- 3.5.6.2 Touch the **'CHANGE SCOPE'** icon. The Ready to Prime screen will appear.

Figure 48: Ready to Prime Screen




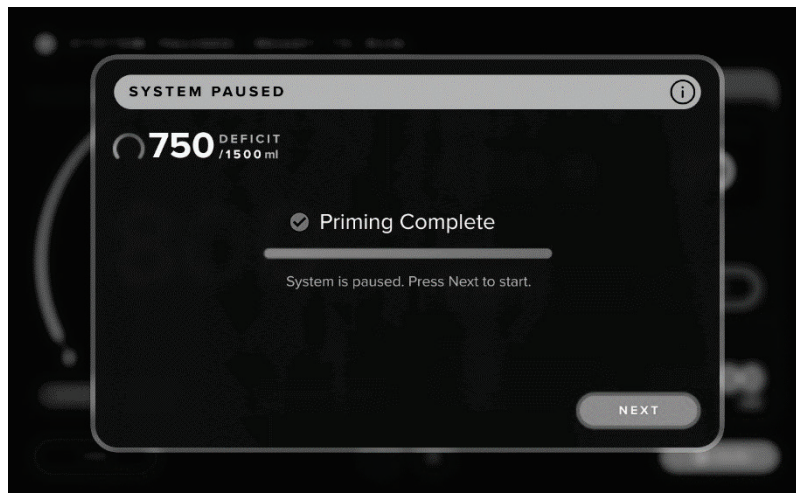
- 3.5.6.3 Direct reprime fluid the Under-Buttocks Drape (UBD).
- 3.5.6.4 Before beginning reprime, ensure Fluid Bag has at least 200mL of fluid to complete the reprime process. If there is not enough fluid, replace the Fluid Bag with a new, full Fluid Bag.
- 3.5.6.5 Prime should be performed at the operative height.
-  **WARNING!**  
Do not prime inside the patient.
- 3.5.6.6 Follow the prompts and touch the **'PRIME'** icon.
- 3.5.6.7 When the prime and calibration of the hysteroscope are complete, the Priming Complete screen will be displayed.

Figure 49: Priming Complete Screen





- 3.5.6.8 Touch the **'NEXT'** icon to continue.
- 3.5.6.9 Refer to the hysteroscope Instructions for Use for complete instructions on the use and operation of the hysteroscope, including warnings and cautions.



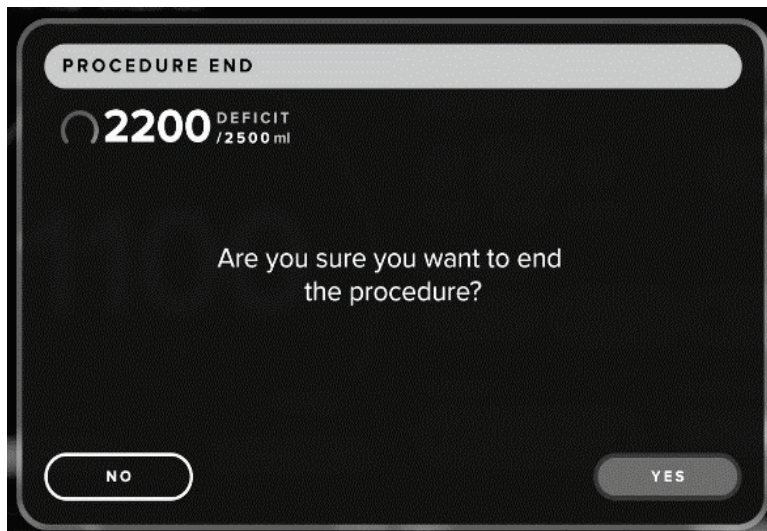
**Caution!**

Failure to reprime after changing hysteroscope may affect uterine pressure control.

### 3.6 Ending the Procedure

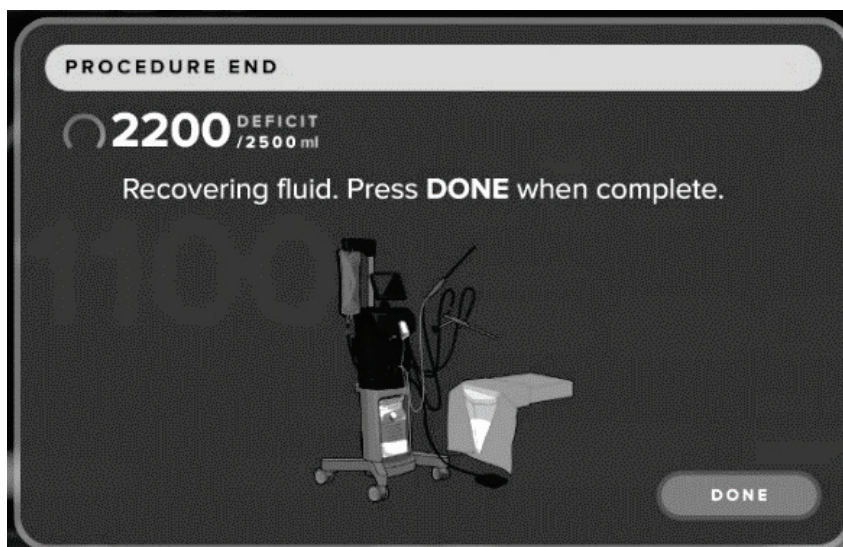
- 3.6.1 When the procedure is complete, touch the **'END'** icon.
- 3.6.2 The system displays a message confirming that you want to end the procedure.

Figure 50: Procedure End Confirmation Screen



- 3.6.3 To end the procedure, touch the **'YES'** icon. To continue the procedure, touch **'NO'**.
- 3.6.4 The system displays a screen to notify that the system is recovering fluid.

Figure 51: Recovering Fluid Screen



3.6.5 The Fluent Pro Out-FloPak will continue to evacuate fluid to ensure an accurate deficit value and all resected tissue is captured.



**WARNING!**

Do not remove the Fluent Pro Out-FloPak and Waste Bag if you want to allow suction to continue to run to remove excess fluid from the Under-Buttocks Drape (UBD) to accurately reflect the deficit. If the Fluid Bag or Waste Bag are removed at this time, the deficit will need to be calculated manually.

3.6.6 When you feel the excess fluid has been removed from the Under-Buttocks Drape (UBD), touch the **'DONE'** icon.

3.6.7 The system displays a Procedure Complete screen that displays the following final procedure data:

- Fluid Deficit
- Total Fluid In
- Cutting Time

3.6.8 To exit the Procedure Complete screen, perform the following steps:

3.6.8.1 Retrieve Tissue Trap (specimen).

3.6.8.2 Remove disposables.

3.6.9 Once FloPaks have been removed from the system, the **'EXIT'** icon will be activated.

3.6.10 Select **'EXIT'**. The Launch screen will be displayed, allowing you to begin a new procedure or to access the last procedure data.

3.6.11 For specifics on disassembly and disposal see Section 4.1.

Note: If you forget to record the results at the end of the procedure, the Fluent Pro Fluid Management System will retain the results from the last procedure. See below for details on how to view last procedure data.

### 3.7 Last Procedure Data

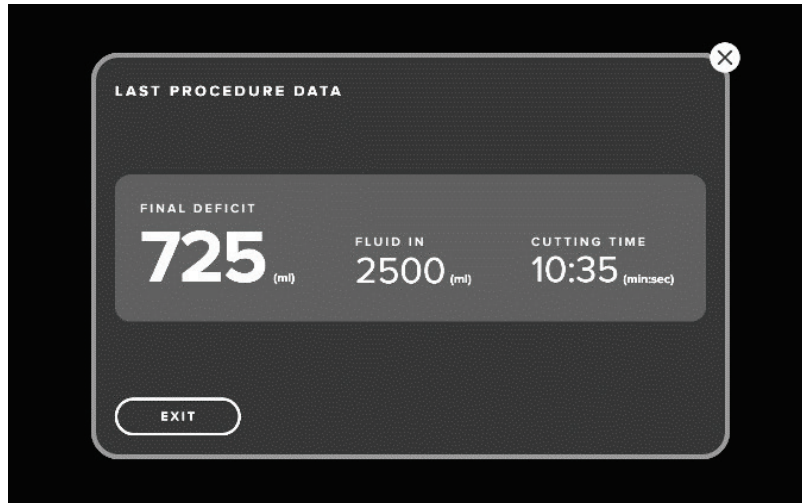
3.7.1 To access data from the last procedure, prior to starting a new procedure, perform the following steps:

3.7.1.1 On the System Setup screen, touch the **'LAST PROCEDURE DATA'** icon.

3.7.1.2 The following final data will be displayed from the last procedure:

- Fluid Deficit
- Total Fluid In
- Cutting Time

Figure 52: Last Procedure Data Screen



Note: In the event of a power failure, refer to Section 5.2 for retrieval of last procedure data.

### 3.8 Replacing Components

Depending on the procedure, you may need to replace disposable components. This Section provides information and instructions for replacing the Fluid Bag, Waste Bag, and Tissue Trap while using the Fluent Pro System. To alert you of changes, the Fluent Pro Fluid Management System Fluid Bag Hooks and Waste Bag Hooks contain built-in scales, and the system will prompt you if you need to take action. The System will not alert you if the tissue trap is near capacity or full, please monitor tissue trap for capacity.

#### 3.8.1 Adding the Fluid Bag

- 3.8.1.1 The system does not need to be paused in order to add or change a Fluid Bag, as long as a second bag is hung and unclamped.
- 3.8.1.2 Replace the Fluid Bag when the Fluid Bag is almost empty or when alerted by the system.
- 3.8.1.3 If leaving an empty bag on Hooks, ensure that empty Fluid Bag is clamped.
- 3.8.1.4 Hang only a single Fluid Bag on the Fluid Bag Hooks at a time.
- 3.8.1.5 A minimum of one Fluid Bag should always be unclamped when the system is running.
- 3.8.1.6 Perform the following steps to replace the Fluid Bag during a procedure:

 **WARNING!**

Do not place excessive force or weight on the Fluid Bag Hooks. Doing so may result in an inaccurate fluid deficit value, causing risk to patient safety.

Only hang one (1) Fluid bag per supply hook. Hanging more than 1 fluid bag per supply hook can affect the system's ability to recognize empty fluid bags during procedure.

##### 3.8.1.6.1 One Fluid Bag on Fluid Bag Hooks

- 3.8.1.6.1.1 Hang a new Fluid Bag on the vacant hook.
- 3.8.1.6.1.2 The total volume hung on each Fluid Bag Hook should not exceed 3L of fluid.
- 3.8.1.6.1.3 Spike the new Fluid Bag.
- 3.8.1.6.1.4 Open clamp on the new Fluid Bag.
- 3.8.1.6.1.5 Close the clamp on the empty Fluid Bag.

##### 3.8.1.6.2 Two Fluid Bags on Fluid Bag Hooks (One Bag Unclamped)

- 3.8.1.6.2.1 Remove the non-active empty Fluid Bag and unspike.
- 3.8.1.6.2.2 Hang a new Fluid Bag on the vacant Fluid Bag Hook.
- 3.8.1.6.2.3 Spike the new Fluid bag.
- 3.8.1.6.2.4 Unclamp the Fluid bag tubing on the hanging full Fluid Bag when ready.
- 3.8.1.6.2.5 Clamp the Fluid Bag tubing on the empty Fluid Bag.

**3.8.1.6.3** Two Fluid Bags on Fluid Bag Hooks (Both Bags Unclamped)

- 3.8.1.6.3.1 Clamp Fluid Bag tubing on either Fluid Bag.
- 3.8.1.6.3.2 Remove the clamped Fluid Bag and unspike.
- 3.8.1.6.3.3 Hang a new Fluid Bag on the vacant Fluid Bag Hook.
- 3.8.1.6.3.4 Spike and unclamp new Fluid Bag when ready.
- 3.8.1.6.3.5 Repeat with second empty bag (if needed) or clamp when empty.

**3.8.2 Replacing the Waste Bag**

3.8.2.1 Replace the Waste Bag when the Waste Bag is almost full or when the system alerts you. The system will pause when approximately 6000mL of fluid is in the Waste Bag.

3.8.2.2 If the system is running, touch the '**PAUSE**' icon to pause the system.

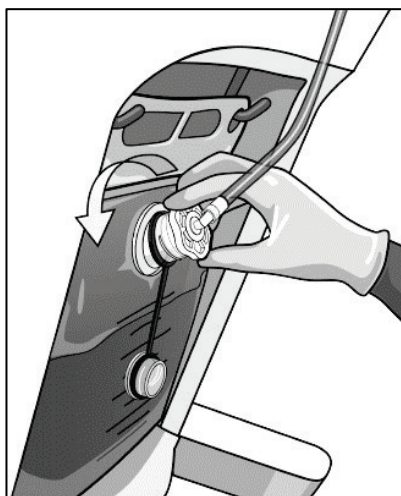


**WARNING!**

Changing the Waste Bag without pausing the system may lead to overestimation of deficit.

3.8.2.3 Remove the Waste Bag Connector from the Waste Bag by rotating the Connector counterclockwise.

*Figure 53: Remove Waste Bag Connector*



**WARNING!**

Do not place excessive force or weight on the Waste Bag Hooks. Doing so may result in an inaccurate fluid deficit value, causing risk to patient safety.

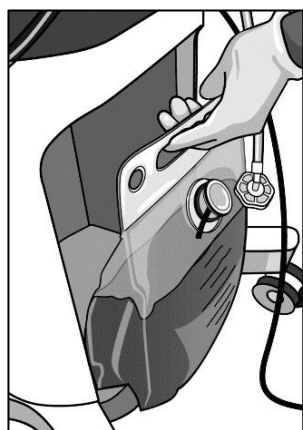
- 3.8.2.4 Screw the Waste Bag cap onto the Waste Bag by rotating the cap clockwise.

*Figure 54: Screw Waste Bag Cap onto Waste Bag*



- 3.8.2.5 Remove the full Waste Bag from the Waste Bag Hooks and discard the Waste Bag according to facility protocols.

*Figure 55: Remove Full Waste Bag*



- 3.8.2.6 Hang a new Waste Bag onto the Waste Bag Hooks.
- 3.8.2.7 Attach the Out-FloPak Waste Bag Connector onto the Waste Bag by rotating the connector clockwise.

*Figure 56: Install Waste Bag Connector*

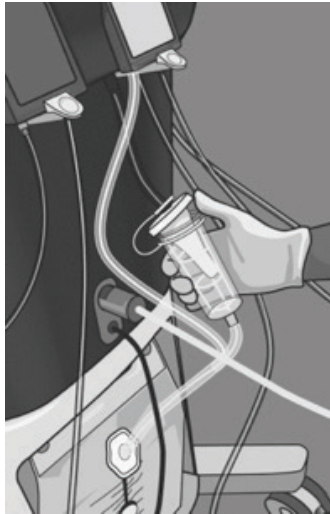


- 3.8.2.8 If 'Missing Waste Bag' error is displayed, ensure the Waste Bag is installed properly on the Hooks, touch the **'CLEAR'** icon and continue with the procedure.

3.8.3 **Replacing the Tissue Trap**

- 3.8.3.1 If the tissue trap appears to be full, by expanding outside of the internal basket, the tissue trap is near capacity and must be changed. Failure to do so could result in loss of tissue sample. The System will not alert you if the tissue trap is near capacity or full, please monitor tissue trap for capacity.
- 3.8.3.2 Touch the **'PAUSE'** icon to pause the system.
- 3.8.3.3 Open the lid of the Tissue Trap Canister.

*Figure 57: Open Tissue Trap Canister Lid*



- 3.8.3.4 Remove the Tissue Trap from the Canister (leaving the basket behind) and place into a specimen container.
- 3.8.3.5 Place a new Tissue Trap into the Tissue Trap Canister.
- 3.8.3.6 Close the Tissue Trap Canister lid securely.

This page is intentionally left blank

After Procedure



This page is intentionally left blank

## 4 After Procedure

### 4.1 Disassembly and Disposal



#### WARNING!

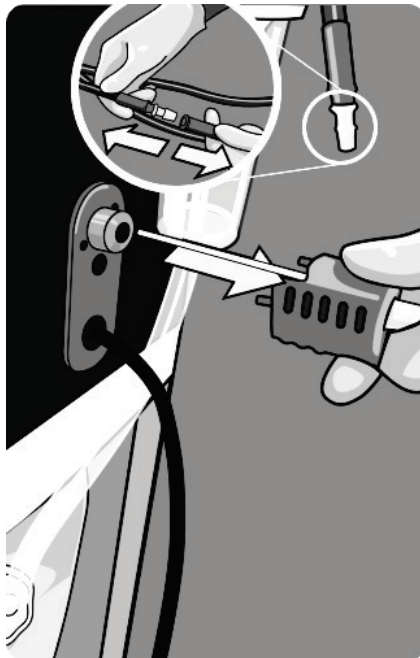
Fluent Pro Procedure Kits are single use disposables. Do not re-use or reprocess any of the components contained within the single-use Procedure Kit.

Note: Comply with your facility's disposal and hygiene rules when disposing of Fluent Pro Procedure Kits, the Tissue Trap, fluid collected, and the Waste Bag.

#### 4.1.1 Breakdown MyoSure Tissue Removal Device (TRD)

- 4.1.1.1 Remove the TRD from the hysteroscope.
- 4.1.1.2 Disconnect the MyoSure TRD suction tube from the Out-FloPak tubing.
- 4.1.1.3 Disconnect the drive cable of the MyoSure TRD from the MyoSure TRD Panel.

Figure 58: Disconnecting the MyoSure TRD



- 4.1.1.4 Dispose of the TRD according to your facility's protocol.

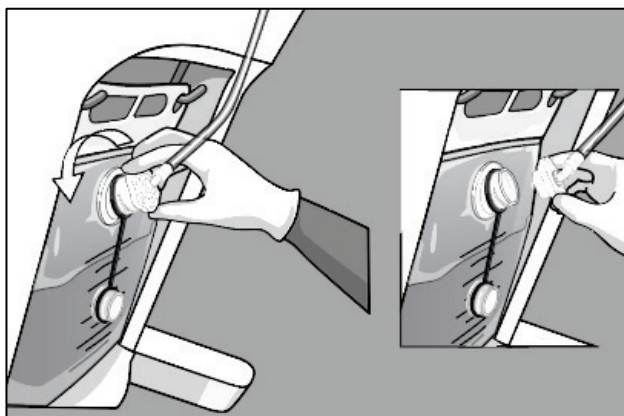
#### 4.1.2 Collect Pathology

- 4.1.2.1 Locate a specimen container (not supplied).
- 4.1.2.2 Open the lid of Tissue Trap Canister.
- 4.1.2.3 Remove the Tissue Trap from the Canister (leaving basket behind) and place it into the specimen container. If additional tissue is to be collected, refer to Section 3.8.3 for Tissue Trap replacement.

### 4.1.3 Dispose of Waste Materials

- 4.1.3.1 Remove the Waste Bag Connector from the Waste Bag by rotating the connector counterclockwise.

*Figure 59: Remove Waste Bag Connector*



**WARNING!**

Do not place excessive force or weight on the Waste Bag Hooks. Doing so may result in an inaccurate fluid deficit value, causing risk to patient safety.

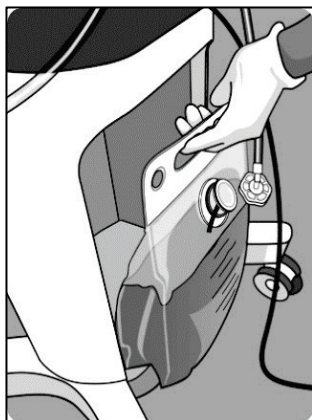
- 4.1.3.2 Screw the Waste Bag cap onto the Waste Bag by rotating the cap clockwise.

*Figure 60: Screw Waste Bag Cap onto Waste Bag*



- 4.1.3.3 Remove the full Waste Bag from the Waste Bag Hooks and discard the Waste Bag according to facility protocols.

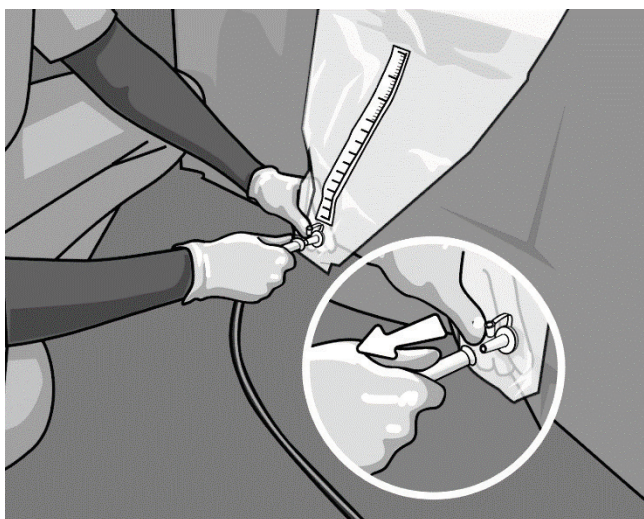
*Figure 61: Remove Full Waste Bag*



#### 4.1.4 **Disassemble the Under-Buttocks Drape (UBD)**

- 4.1.4.1 Disconnect the Out-FloPak tubing yellow connector from the Under-Buttocks Drape (UBD) Port.

*Figure 62: Disconnect UBD*



- 4.1.4.2 Dispose of the Under-Buttocks Drape (UBD) according to your facility's protocol.

#### 4.1.5 **Disassemble the Hysteroscope**

- 4.1.5.1 Clamp the hysteroscope Inflow Tube.
- 4.1.5.2 Remove the hysteroscope Inflow Tube.
- 4.1.5.3 Remove the hysteroscope Outflow Tube.

#### 4.1.6 **Disassemble the Fluent Pro In-FloPak**

- 4.1.6.1 Clamp the Fluid Bag Tube.
- 4.1.6.2 Remove the spike from the Fluid Bag.

- 4.1.6.3 Depress the In-FloPak lever and remove the In-FloPak from the Fluent Pro Fluid Management System console.
- 4.1.6.4 Dispose of the Fluent Pro In-FloPak according to your facility's protocol.

#### 4.1.7 **Disassemble the Fluent Pro Out-FloPak**

- 4.1.7.1 Depress the Out-FloPak lever and remove the Out-FloPak from the Fluent Pro Fluid Management System console.
- 4.1.7.2 Dispose of the Fluent Pro Out-FloPak according to your facility's protocol.

#### 4.1.8 **Shutdown and Disassemble the Fluent Pro Fluid Management System**

- 4.1.8.1 Push the Power Button to power down the system.
- 4.1.8.2 The system displays a message confirming that you want to end the procedure. The system will ding while the confirmation screen is active.
- 4.1.8.3 To power down the system, touch the **'YES'** icon.
- 4.1.8.4 A powering down screen will appear along with a status bar. Do not unplug the system until the sequence is complete and the screen is dark. When the system is powered down and plugged in, the power button will be illuminated orange.
- 4.1.8.5 Store the foot pedal in the Foot Pedal Basket.
- 4.1.8.6 Unplug the Fluent Pro Fluid Management System console Power Cord.
- 4.1.8.7 Wrap the Power Cord around the cord wrap on the back of the system.

### 4.2 **Cleaning the Fluent Pro Fluid Management System**

- 4.2.1 Ensure the Fluent Pro Fluid Management System is disconnected from the electrical source.
- 4.2.2 Wipe the surface of the system with a soft cloth moistened with disinfectant. For information regarding concentration of disinfectant, refer to documentation provided by the manufacturer of the disinfectant. Examples of disinfectant include:
  - 5% dishwashing soap in water
  - 0.14% Ammonium chloride (PDI Sani-Cloth AF3, PDI Sani-Cloth HB, or equivalent)
  - Commercially available isopropyl alcohol solution (typically 70% isopropyl alcohol by volume, undiluted)
  - 10% chlorine bleach and water solution (consisting of one part commercially available bleach and nine parts water)



Do not sterilize or immerse the Fluent Pro Fluid Management System in disinfectant.

### 4.3 **Storing the System**

- 4.3.1 Prior to storing the system, complete Section 4.1 and 4.2.
- 4.3.2 To unlock the wheels, use your foot to lift (upward) the lever on each Wheel Lock.
- 4.3.3 Transport the system using the 360° Handle.



Only use the Handle to move or position the Fluent Pro Fluid Management System. Do not pull or push the system with the IV pole or Touchscreen Monitor.



Do not place excessive force or weight on the Fluid Bag Hooks. Doing so may result in an inaccurate fluid deficit value, causing risk to patient safety.



**WARNING!**

Do not place excessive force or weight on the Waste Bag Hooks. Doing so may result in an inaccurate fluid deficit value, causing risk to patient safety.

This page is intentionally left blank

# Troubleshooting



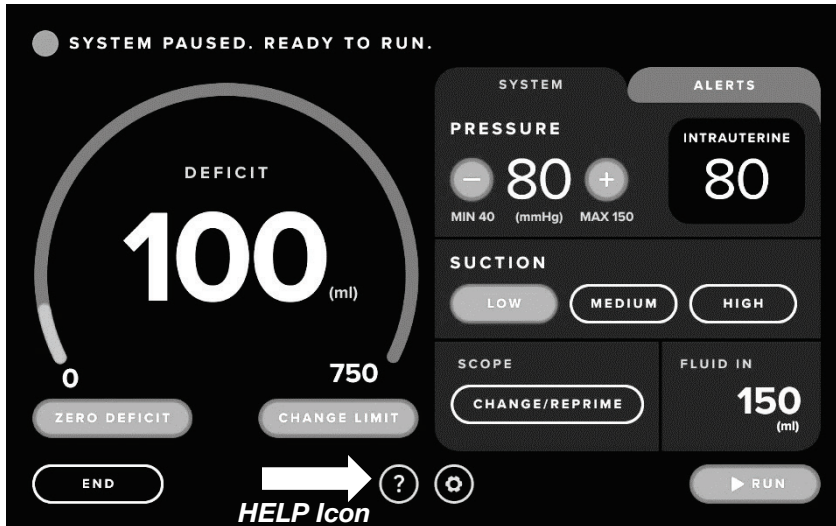
This page is intentionally left blank

## 5 Troubleshooting

### 5.1 Help

Touch the **'HELP'** icon at any time to access the help menu and display step-by-step instructions on the Touchscreen. The **'HELP'** icon is located at the bottom of the Launch screen, Setup screen, Confirmation screen and Procedure screen.

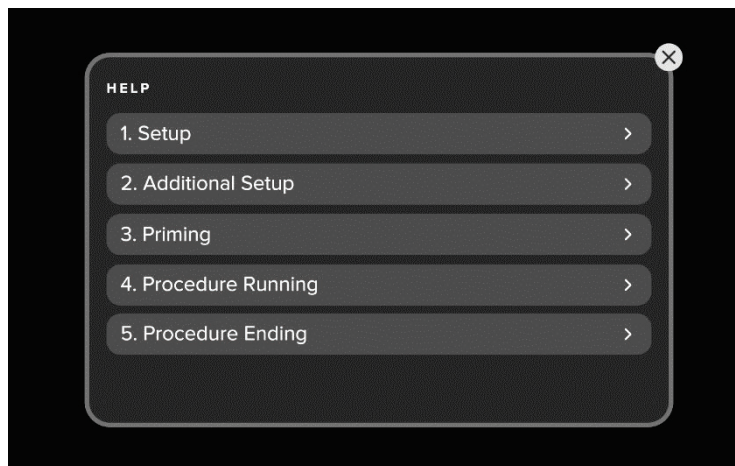
Figure 63: Help Icon Location



#### 5.1.1 Help Screen Menu

- 5.1.1.1 On the Help screen menu select the desired topic to display the Help screen for that step.

Figure 64: Help Screen Menu



- 5.1.1.2 Follow the on-screen prompts.

5.1.2 **Help with Setup**

5.1.2.1 On the Setup and Additional Setup Help screen menu, select the desired topic to display the Help screen for that step.

Figure 65a: Setup Help Menu

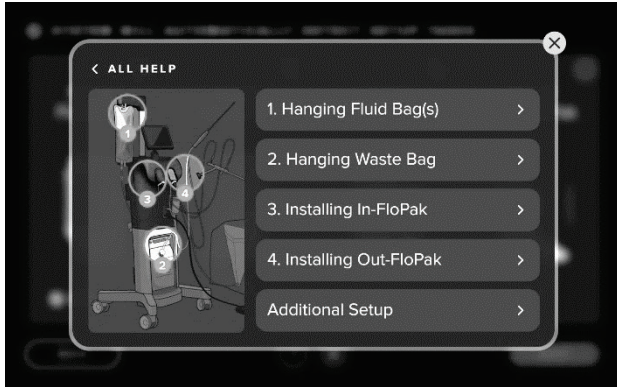
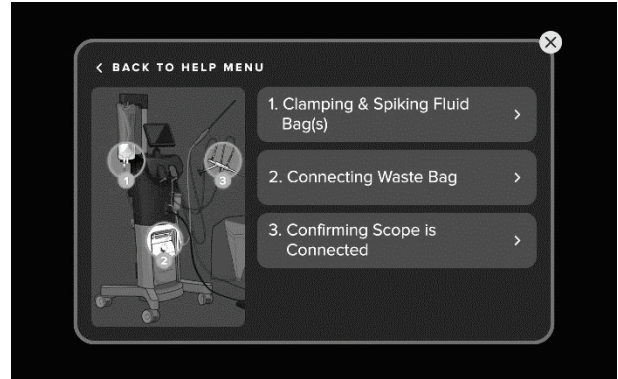


Figure 65b: Additional Setup Help Menu



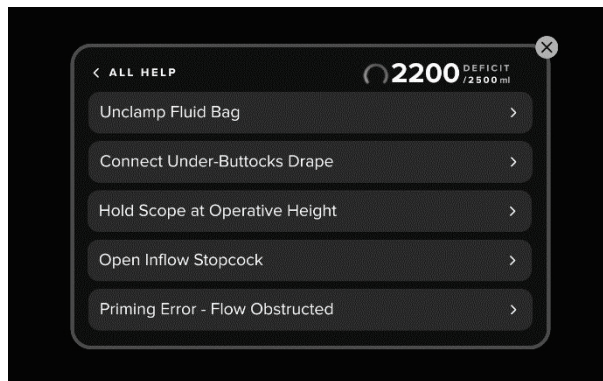
5.1.2.2 Follow the on-screen prompts.

5.1.3 **Help with Priming**

5.1.3.1 On the Priming Help screen menu select the desired topic to display the Help screen for that step.

5.1.3.2 Follow the on-screen prompts.

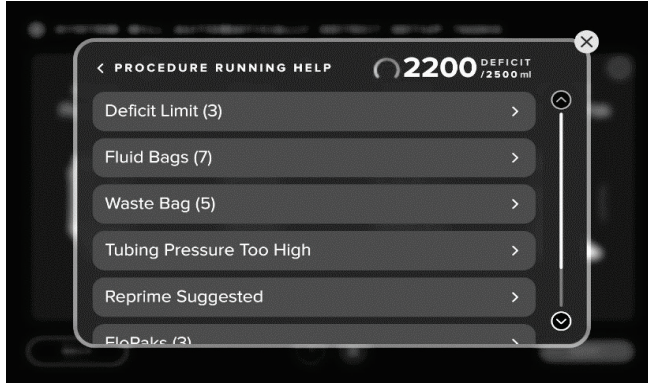
Figure 66: Priming Help Screen



5.1.4 **Help During the Procedure**

- 5.1.4.1 On the Procedure Running Help screen menu select the desired topic to display the Help screen for that step. If a submenu appears, select a subtopic from the menu to display the Help screen.

*Figure 67: Procedure Running Help Screen*

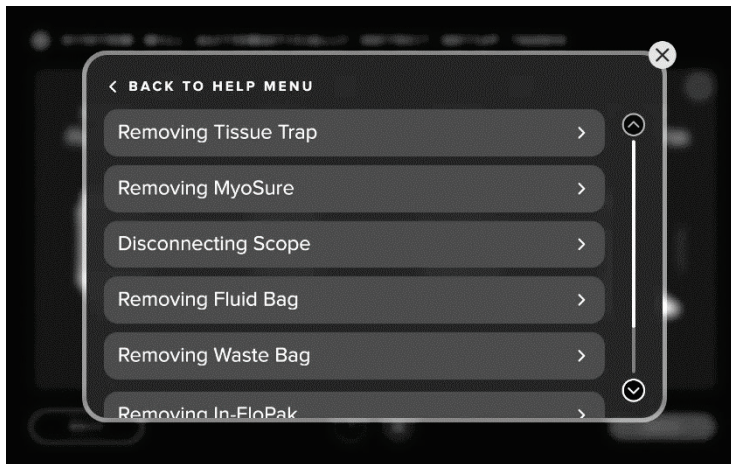


- 5.1.4.2 Follow the on-screen prompts.

5.1.5 **Help with Procedure End**

- 5.1.5.1 On the Procedure End Help screen menu, select the desired topic to display the help screen for that step.

*Figure 68: Procedure End Help Screen*

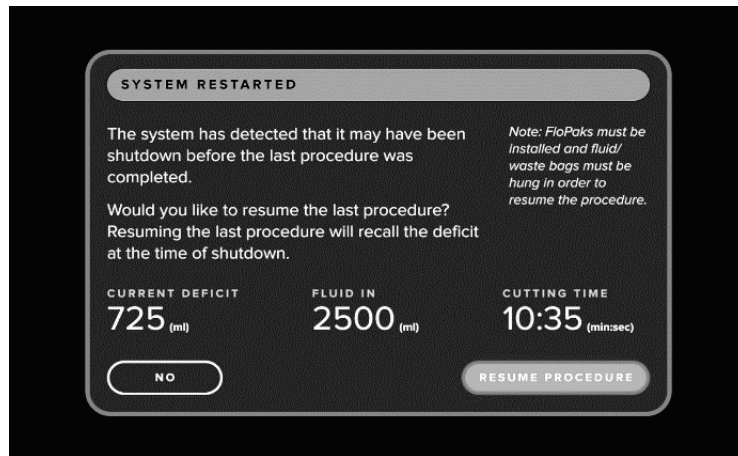


- 5.1.5.2 Follow the on-screen prompts.

## 5.2 Resume Procedure (After Power Loss or Shutdown)

If the system is shutdown or a power loss occurs prior to completion of a procedure, the option of resuming the last procedure will be available. Upon startup, the System Restarted screen is displayed. This screen displays last procedure data, including Current Deficit, Fluid In and Cutting Time. Touch the **'RESUME PROCEDURE'** icon to resume the last procedure. Selecting **'NO'** will start a new procedure and all previous procedure data will be lost. If a new procedure is started unintentionally, the deficit will need to be calculated manually.

Figure 69: System Restarted Screen



## 5.3 Troubleshooting

### 5.3.1 FloPaks not detected

- 5.3.1.1 Firmly press towards the bottom of the FloPak to ensure the top of the FloPak is flush with the front of the console and to engage the Lever.

### 5.3.2 Loss of Suction

#### 5.3.2.1 Outflow

- 5.3.2.1.1 Ensure the hysteroscope outflow tubing luer lock on the Out-FloPak is securely connected to the hysteroscope outflow channel.
- 5.3.2.1.2 Ensure nothing is obstructing or occluding the hysteroscope outflow tubing.
- 5.3.2.1.3 Reprime the hysteroscope. Refer to Section 2.7.9.

#### 5.3.2.2 Under-Buttocks Drape

- 5.3.2.2.1 Ensure the Under-Buttocks Drape tubing suction connector is connected to the Under-Buttocks Drape port and that the Under-Buttocks Drape is not occluding the tubing.
- 5.3.2.2.2 Ensure nothing is obstructing or occluding the Under-Buttocks Drape tubing.

#### 5.3.2.3 MyoSure TRD

- 5.3.2.3.1 Ensure the MyoSure TRD suction connector is securely connected to the MyoSure TRD barb on the Out-FloPak.
- 5.3.2.3.2 Ensure nothing is obstructing or occluding the MyoSure TRD tubing.

### 5.3.3 Inadequate Suction

- 5.3.3.1 Increase or decrease suction settings. Refer to Section 3.4 for instructions.

5.3.4 **Poor Visibility**

- 5.3.4.1 Verify that the Fluid Bag Clamp is open.
- 5.3.4.2 If bleeding is obscuring the visibility, the Intrauterine Pressure may need to be adjusted during the procedure to provide a tamponade effect.
- 5.3.4.3 If performing a MyoSure procedure, advance the MyoSure Tissue Removal Device to the fundus and allow circulation of fluid through the non-active blade to clear field.
- 5.3.4.4 Ensure the outflow stopcock is fully open.

5.3.5 **Poor Uterine Distension**

- 5.3.5.1 Avoid over dilation of the cervix. If the cervix is over dilated, use a second tenaculum to seal the cervix.
- 5.3.5.2 Verify the Fluid Bag Clamp is open.
- 5.3.5.3 Ensure the inflow tubing is not occluded or pinched.
- 5.3.5.4 Ensure the inflow stopcock is fully open.
- 5.3.5.5 Ensure the pressure setting is adequate.
- 5.3.5.6 Reprime the hysteroscope. Refer to Section 2.7.9.

5.3.6 **Tissue Resection Difficulty**

- 5.3.6.1 Ensure the appropriate MyoSure TRD is being used for the tissue being resected.
- 5.3.6.2 Ensure the MyoSure TRD flexible drive cable is fully inserted into the corresponding connection on the MyoSure Panel of the Fluent Pro Fluid Management System.
- 5.3.6.3 Ensure the MyoSure TRD is fully inserted through the hysteroscope, and the entire cutting window is visualized at the end of the hysteroscope.
- 5.3.6.4 Orient the MyoSure TRD cutting window against the tissue when the foot pedal is activated. If you see flashing from the scope, it means the window is not pushing directly on the tissue.
- 5.3.6.5 Ensure the outflow tubing is not occluded or pinched.
- 5.3.6.6 Avoid applying excessive force to the MyoSure TRD handle.

5.3.7 **Fluid Deficit Difficulty**

- 5.3.7.1 Refer to scale calibration check, Section 6.1.1



**WARNING!**

If the deficit is rapidly increasing, or the visualization field does not respond to a change in pressure set point, this may indicate that the uterus has been perforated or that fluid is escaping elsewhere. Examine the visual field for injury or a leak from the cervix.

5.3.8 **Power Loss**

- 5.3.8.1 If the Fluent Pro Fluid Management System powers down or loses power unexpectedly, wait at least 15 seconds then power on the system and follow on-screen prompts. To resume the previous procedure, refer to Section 5.2.
- 5.3.8.2 If the system will not power on, verify the following:



**WARNING!**

Unplug the Power Cord from the wall outlet and from the system before checking the fuse.





When replacing a fuse, use only type T5AH, 250V fuses.

- 5.3.8.2.1 The Power Cord is properly connected to both the Power Port on the rear of the Fluent Pro Fluid Management System and to a wall outlet.
- 5.3.8.2.2 The wall outlet has power. Test the outlet by plugging in another device to ensure it is working properly.
- 5.3.8.2.3 If the system has adequate power running to it but it will still not power on, the fuse may be defective. To replace the fuse:
- 5.3.8.2.4 Disconnect the Power Cord from the wall outlet.
- 5.3.8.2.5 Obtain the appropriate fuse(s) for replacement. The approved fuse type is T5AH, 250 V. There are 2 per system.
- 5.3.8.2.6 Locate the fuse holder located in the power module on the rear of the system. Using a small flathead screwdriver, remove the fuse holder.
- 5.3.8.2.7 Pull the fuse out of the fuse holder and inspect for damage.
- 5.3.8.2.8 Insert the new fuse(s). Use only the type of fuse: T5AH, 250 V fuses.
- 5.3.8.2.9 Insert the fuse holder.
- 5.3.8.2.10 Reconnect the Power Cord to the wall outlet power then power on the system and follow on-screen prompts. To resume the previous procedure, refer to Section 5.2 and turn the system on to ensure it is working properly.

### 5.3.9 System Frozen

- 5.3.9.1 If the system is frozen and cannot be shut down by touching the Power Button, perform a hard shutdown by holding the Power Button down for 5 seconds. Power on the system and follow on-screen prompts. To resume the previous procedure, refer to Section 5.2.

5.3.10 **GUI Notifications and Alerts**

 5.3.10.1 **Notifications and Troubleshooting (Screen Flashing Yellow and Orange)**

Table 1: Real-time Display, Notifications and Troubleshooting

Notification Message	Description	Resolution
Fluid Bag(s) Low	Volume in Fluid Bag is less than 500mL	Add Fluid Bag with volume above 500mL. Spike and unclamp the new bag.
Waste Bag Almost Full	Volume in Waste Bag is greater than 5500mL	Manually pause the procedure if running. Remove full Waste Bag and replace with a new empty Waste Bag. Resume procedure.
Approaching Deficit Limit	The deficit value is at or above 75% of the set limit	Consider increasing the deficit limit if clinically appropriate or stopping the procedure.
High Fluid Loss	The deficit value rose 300 mL or more over the last 60 seconds of continuous run time	Check for excessive cervical leakage. Verify that the leakage is being captured in the under-buttocks drape and returning to the waste bag. Check for signs of uterine perforation.
Reprime Suggested	A change in pressure was detected due to a hysteroscope change or incomplete prime	Reprime the system.
MyoSure Device Not Found	System does not detect that the MyoSure device has been installed	Ensure the MyoSure TRD is properly plugged in and tap foot pedal to resume. If warning persists, replace MyoSure TRD. Press clear on the GUI.
Excessive Torque Detected	MyoSure TRD speed is too slow	Reduce pressure on device handle and tap foot pedal to resume. If warning persists, replace MyoSure TRD.
MyoSure Motor Temperature High	MyoSure TRD motor is too hot	If warning persists, replace MyoSure TRD
MyoSure Motor Overcurrent 1	MyoSure TRD current is too high	If warning persists, replace MyoSure TRD
MyoSure Motor Overcurrent 2	MyoSure TRD electrical issue	If warning persists, replace MyoSure TRD
MyoSure Motor Under Voltage	MyoSure TRD voltage is too low	If warning persists, replace MyoSure TRD
MyoSure Motor Stalled	MyoSure TRD motor stalled	If warning persists, replace MyoSure TRD



5.3.10.2 Alerts and Troubleshooting (screen flashing Red and Pink)

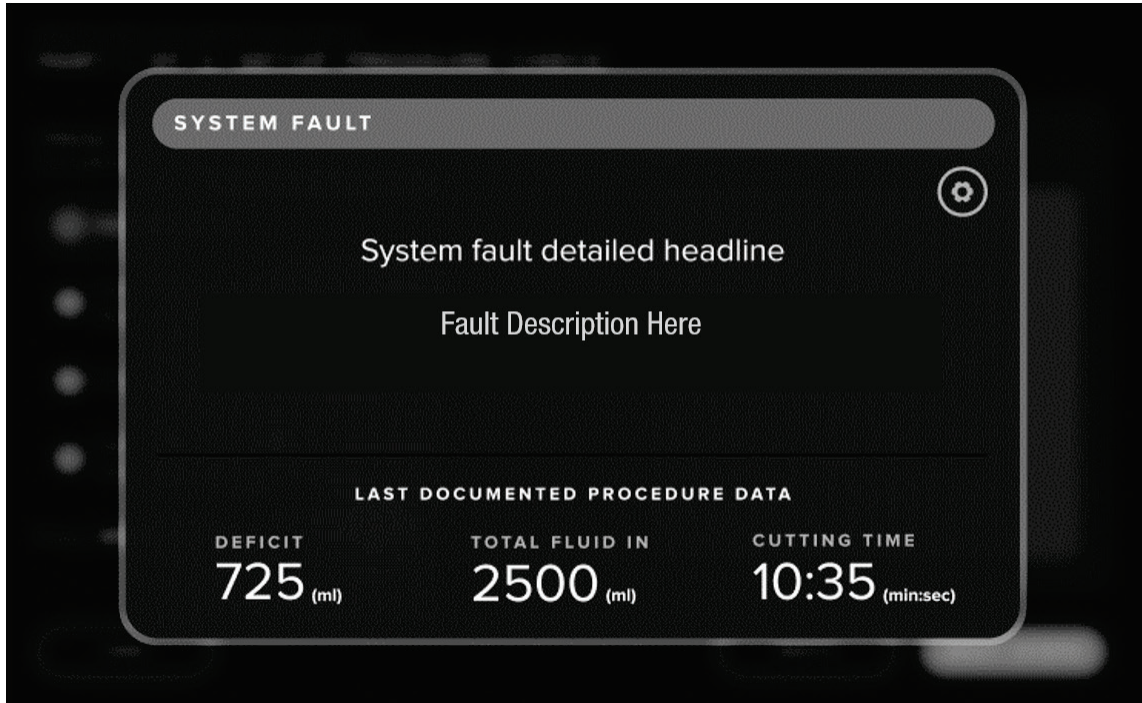
Table 2: Real-time Display, Alerts and Troubleshooting

Alert Message	Description	Resolution
Waste Bag Full	Volume in Waste Bag has reached 6000mL	Remove full Waste Bag and replace with a new empty Waste Bag.
Waste Bag Missing	Weight on Waste Bag Hooks is less than 90g	Hang a Waste Bag on the Waste Bag Hooks. Ensure the bag is level on both Hooks.
Fluid Bag(s) Missing	Weight on both Fluid Bag Hooks is less than 50g each	Hang a Fluid Bag on either Fluid Bag Hook
Fluid Bag(s) Empty	Weight on Fluid Bag Hooks is less than 175g	Replace empty Fluid Bag(s) with new Fluid Bag(s). Press clear on the GUI.
Excessive Movement of Fluid Bag(s) or Nearly Empty Fluid Bag(s)	Fluid Bag Hooks are unstable for at least 25 seconds	Stabilize Fluid Bag(s) or Replace Fluid Bag(s). Do not touch the Fluid Bag Hooks or move the system. Press clear on the GUI.
Excessive Movement of Waste Bag	Waste Bag Hooks are unstable for at least 5 seconds	Stabilize Waste Bag. Do not touch the Waste Bag Hooks or move the system. Press clear on the GUI.
Fluid Bag(s) Clamped or Not Spiked	Fluid is not flowing through the Fluid Bag tubing to the system.	Check that Fluid Bag(s) are spiked and that tubing is unclamped. Press clear on the GUI.
Deficit Limit Reached/Exceeded	The actual deficit is greater than or equal to the set deficit limit	Consider increasing the deficit limit, if clinically appropriate.
Front Fluid Bag Hook Overloaded	Excessive weight is detected on the Front Fluid Bag Hook	Do not lean on the Fluid Bag Hooks. Remove any inappropriate items from the hook. Remove excessive full Fluid Bags from the hook. Press clear on the GUI.
Back Fluid Bag Hook Overloaded	Excessive weight is detected on the Front Fluid Bag Hook	Do not lean on the Fluid Bag Hooks. Remove any inappropriate items from the hook. Remove excessive full Fluid Bags from the hook. Press clear on the GUI.
Waste Bag Hooks Overloaded	Excessive weight is detected on the Front Fluid Bag Hook	Do not lean on the Waste Bag Hooks. Remove any inappropriate items from the hook. Ensure only one (1) Waste Bag is hanging and remove any extra bags. Press clear on the GUI.
In-FloPak Error	The lock pin did not engage with the In-FloPak. In-FloPak is not locked.	Depress the release lever and remove the In-FloPak. Re-install the In-FloPak.
In-FloPak Not Found	In-FloPak was removed or is not fully inserted.	Depress the release lever and remove the In-FloPak. Reinstall the In-FloPak. Ensure the In-FloPak is flush with the Console.
Out-FloPak Not Found	Out-FloPak was removed or is not fully inserted.	Depress the release lever and remove the Out-FloPak. Reinstall the Out-FloPak. Ensure the Out-FloPak is flush with the Console.
Tubing Pressure Too High	The inflow tubing or hysteroscope is blocked in a way that is causing high pressure in the inflow tube.	Open Inflow stopcock or unclamp tubing. Press clear on the GUI.
Priming Error- Flow Obstructed	Inflow stopcock is not fully open or the end of the hysteroscope is obstructed	Open the inflow stopcock fully and ensure there is nothing obstructing the tip of the hysteroscope. Press clear on the GUI and reprime the system.

5.3.10.3 **System Faults**

If a System Fault occurs at any point during a procedure, the System Fault screen is displayed, as shown below. This screen displays information regarding the fault, as well as the last procedure data, including deficit, total fluid in and cutting time. When a system fault occurs, record the displayed procedure data and follow the instructions given on the screen. For details regarding how to resume a procedure following shutdown, refer to Section 5.2. A list of System Faults can be found below.

Figure 70: System Fault Screen



**5.3.10.3.1 System Fault Messages**

Table 3: Real-time Display, System Faults

Fault Message(s)	Resolution
Temperature Fault 1-4	Turn system off. Allow 5 minutes for system to cool down before turning the system on. If problem persists, call Technical Support.
Sensor Data Missing	Sensor calibration required. Call Technical Support.
FloPak Sensor Data Missing	FloPak sensor calibration required. Call Technical Support
Memory Fault 2	Turn system off and on. Upon turning system back on, Last Procedure data may be incorrect. If problem persists, call Technical Support.
System Watchdog Timeout	Turn system off and on. If problem persists, call Technical Support.
Power Fault 1-6	Turn system off and on. If problem persists, call Technical Support.
Initialization Fault 1-8	Turn system off and on. If problem persists, call Technical Support.
Hardware Fault 1-7	Turn system off and on. If problem persists, call Technical Support.
System Fault 1-4	Turn system off and on. If problem persists, call Technical Support.
Internal Communication Fault	Turn system off and on. If problem persists, call Technical Support.
Calibration Fault 1-4	Turn system off and on. If problem persists, call Technical Support.
Recovery Fault 2	Turn system off and on. If problem persists, call Technical Support.
Fluid Scale Fault 1-4	Turn system off and on. If problem persists, call Technical Support.
Waste Scale Fault 1-2	Turn system off and on. If problem persists, call Technical Support.
In-FloPak Fixed Pin Not Detected	Turn system off and on. If problem persists, call Technical Support.
Inflow Sensor Fault 1-2	Turn system off and on. If problem persists, call Technical Support.
Inflow Motor Stopped	Turn system off and on. If problem persists, call Technical Support.
Inflow Direction Fault	Turn system off and on. If problem persists, call Technical Support.
Inflow Speed Fault	Turn system off and on. If problem persists, call Technical Support.
Outflow Sensor Fault 1-2	Turn system off and on. If problem persists, call Technical Support.
Outflow Motor Stopped	Turn system off and on. If problem persists, call Technical Support.
Outflow Direction Fault	Turn system off and on. If problem persists, call Technical Support.
Outflow Speed Fault	Turn system off and on. If problem persists, call Technical Support.
Pressure Sensor Fault 1-4	Turn system off and on. If problem persists, call Technical Support.
MyoSure Motor Stopped	Turn system off and on. If problem persists, call Technical Support.

# Supplementary Information

This page is intentionally left blank

## 6 Supplementary Information

### 6.1 Annual Inspection

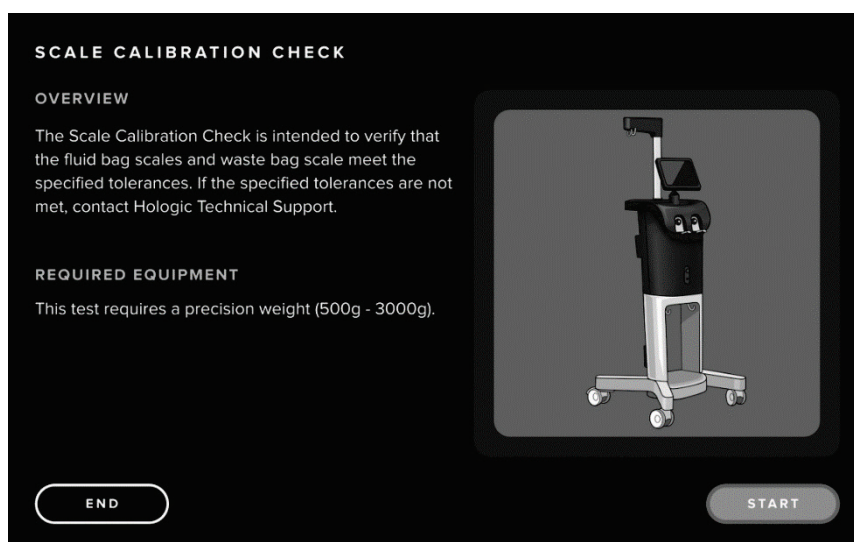
The inspections detailed below are required to be performed annually to assess system functionality and technical safety. Regular inspections will assist in early detection of possible malfunctions. This helps maintain the system and increases its safety and service life. The inspections do not require a service technician but must be performed by Biomedical Engineering.

#### 6.1.1 Scale Calibration Check

The Scale Calibration Check is intended to verify that the Fluid Bag Scales and Waste Bag Scale meet the specified tolerances. This test requires a precision weight (500g – 3000g).

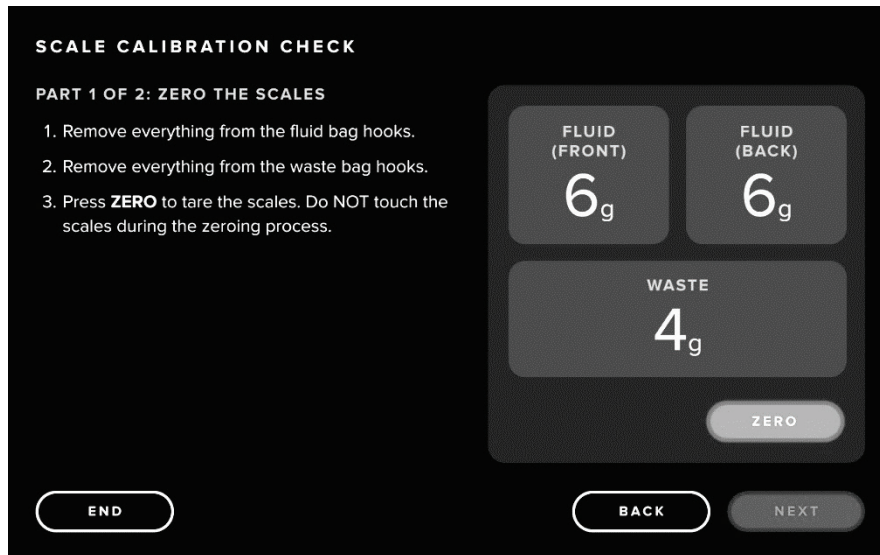
- 6.1.1.1 Press the Power Button on the top of the system to power on the system.
- 6.1.1.2 Touch the **'SETTINGS'** icon.
- 6.1.1.3 Touch the scale calibration **'CHECK'** icon. The Scale Calibration Check screen is displayed.

Figure 71: Scale Calibration Check Overview Screen



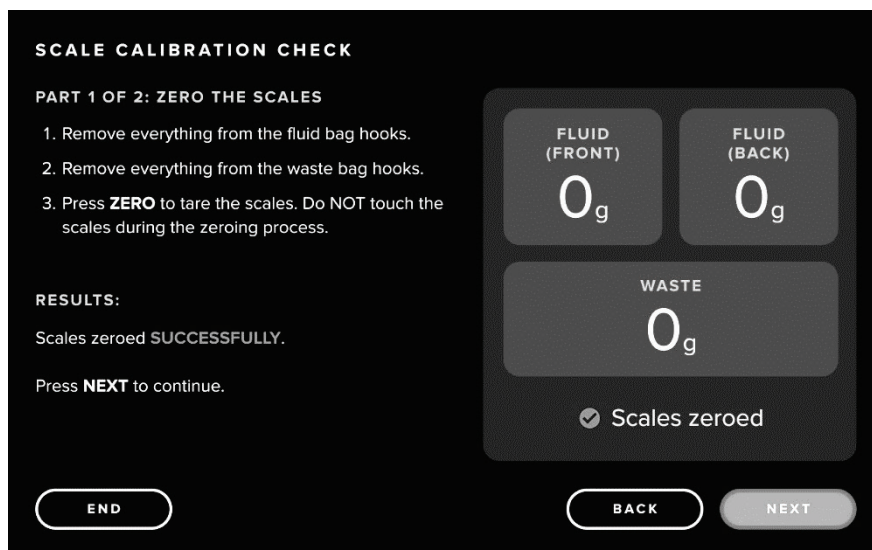
- 6.1.1.4 Touch the **'START'** icon. The Scale Calibration Check Part 1: Zero the Scales screen is displayed.
- 6.1.1.5 Remove everything from the Fluid Hooks and Waste Bag Hooks.

Figure 72: Scale Calibration Check, Part 1 Screen



- 6.1.1.6 Touch the **'ZERO'** icon.
- 6.1.1.7 When scales have been successfully zeroed, the scale values will read zero and a **'✔ SCALES ZEROED'** confirmation will be displayed. If the zeroing fails, follow prompts to retry. If zeroing continues to fail, contact Technical Support.

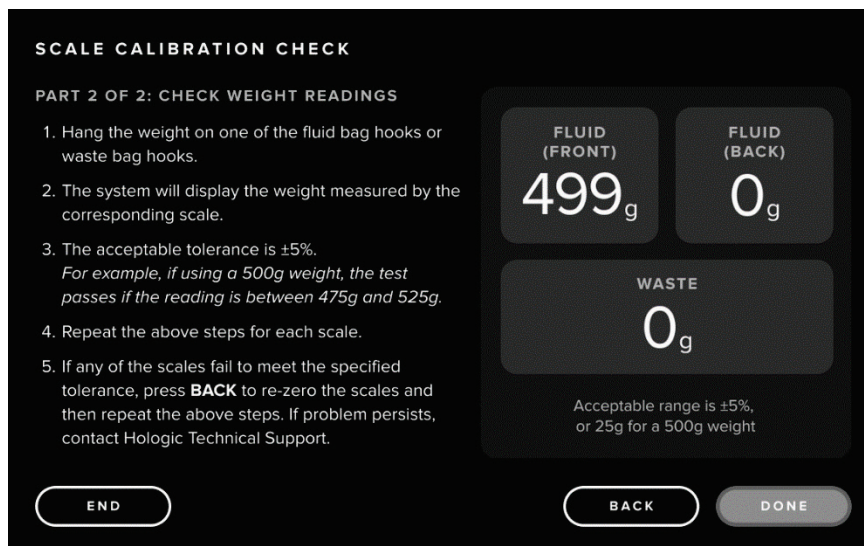
Figure 73: Scale Calibration Check, Scales Zeroed Screen





- 6.1.1.8 Once scales are zeroed, touch the **'NEXT'** icon. The Scale Calibration Check Part 2: Check Weight Readings screen is displayed.

Figure 74: Scale Calibration Check, Part 2 Screen



- 6.1.1.9 Hang a weight on one of the Hooks. The weight should read +/-5%.
- 6.1.1.10 If the reading is not within the acceptable range, touch the back icon and proceed to re-zero the scales and repeat the weight reading steps.
- 6.1.1.11 If the weight readings are still outside of the acceptable range, contact Technical Support.
- 6.1.1.12 If the weight reading is acceptable, remove the weight and repeat the step above for each scale.
- 6.1.1.13 Touch the **'DONE'** icon to return to the Settings screen, then select **'END'** to return to the Setup screen.

6.1.2 **Pressure Calibration Check**

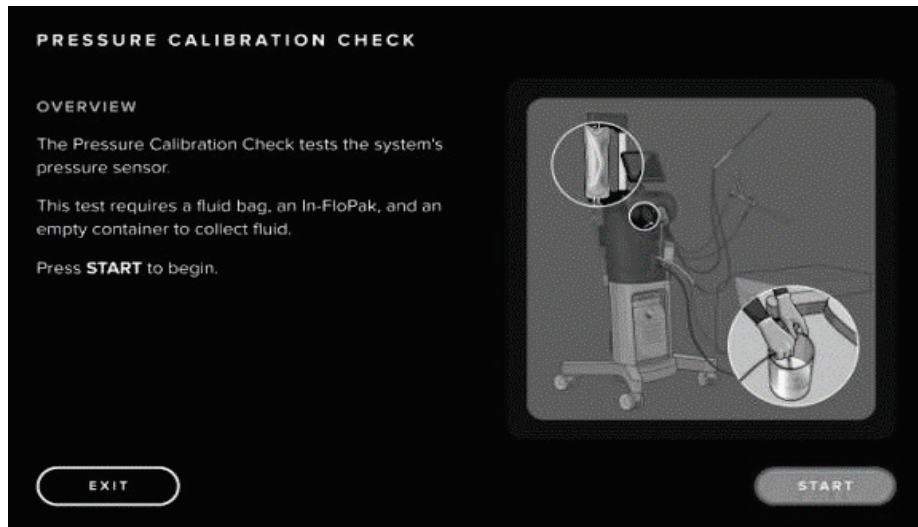
The Pressure Calibration Check tests the system's pressure sensor. This test requires a Fluid Bag, an In-FloPak and an empty container to collect fluid.

6.1.2.1 Press the Power Button on the top of the system to power on the system.

6.1.2.2 Touch the **'SETTINGS'** icon.

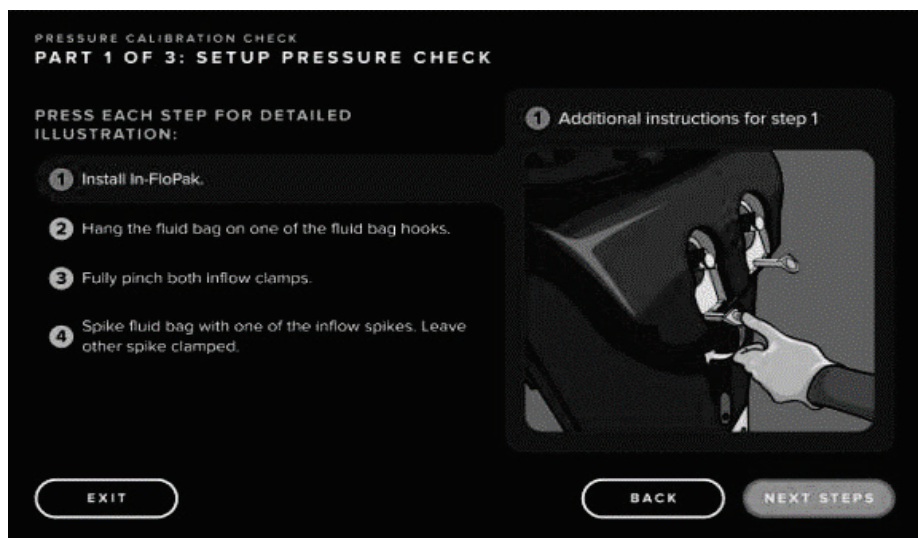
6.1.2.3 Select the pressure calibration **'CHECK'** icon to launch the scale calibration check and press **'START'** to begin.

Figure 75: Pressure Calibration Check Overview Screen



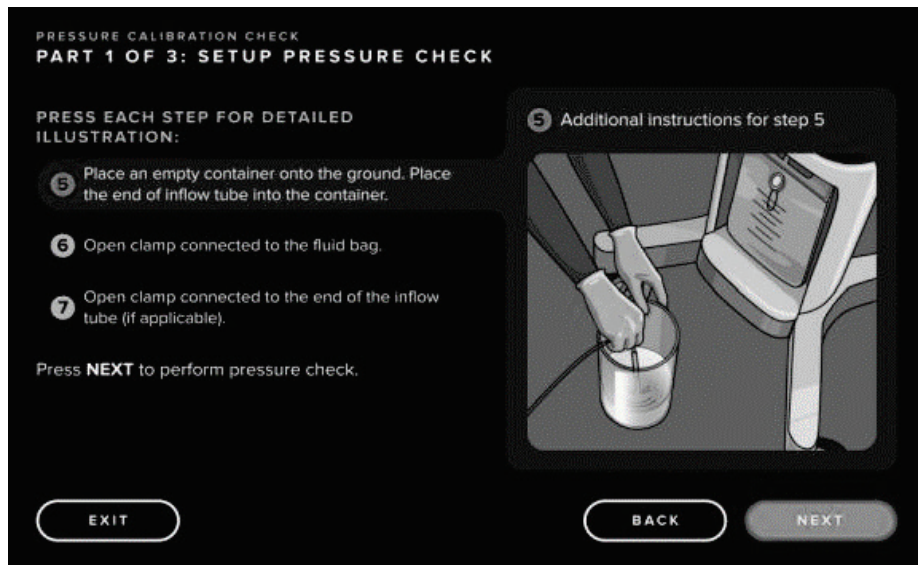
6.1.2.4 Follow prompts to install the In-FloPak, hang the Fluid Bag, pinch the Inflow Clamps and spike the Fluid Bag.

Figure 76: Pressure Calibration Check Steps, Part 1



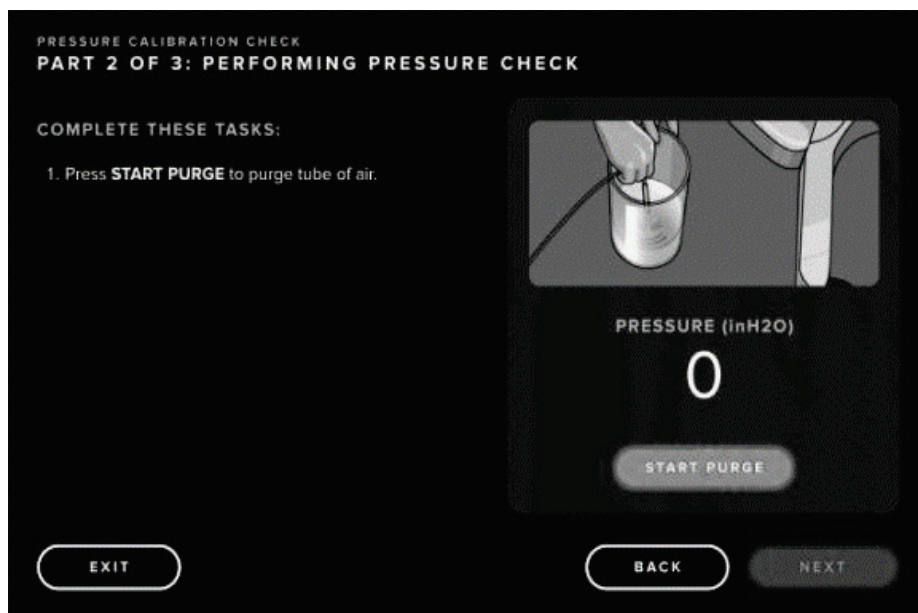
- 6.1.2.5 Press '**NEXT STEPS**' to continue setup including placement of the container and opening the Fluid Bag Clamps.

Figure 77: Pressure Calibration Check Steps, Part 2



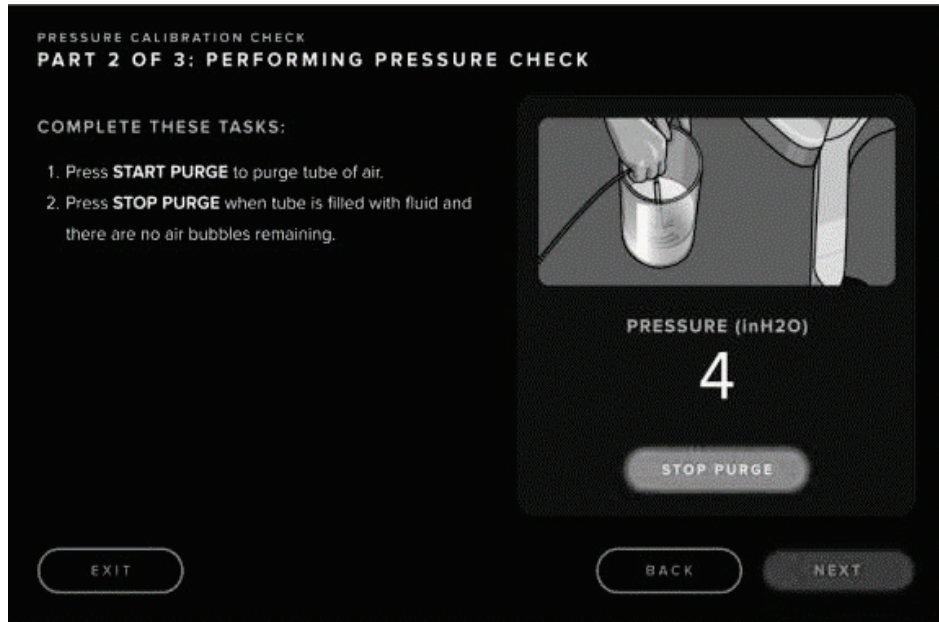
- 6.1.2.6 Press '**NEXT**' to perform pressure check.
- 6.1.2.7 Follow prompts and press '**START PURGE**' to start the purge of air.

Figure 78: Begin Purge for Pressure Calibration Check



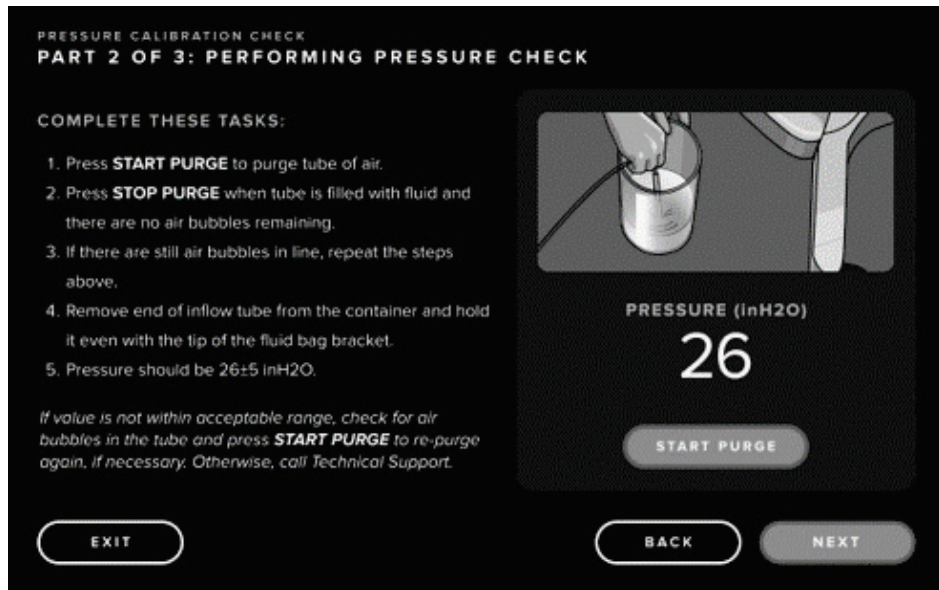
- 6.1.2.8 Press '**STOP PURGE**' once the tube is filled with fluid and there are no air bubbles remaining.

Figure 79: Stop Purge for Pressure Calibration Check



- 6.1.2.9 Remove the end of the Inflow Tube from the container and hold it even with the tip of the Fluid Bag bracket.

Figure 80: Performing Pressure Calibration Check



- 6.1.2.10 Verify the pressure is 26+/-5 in H2O.
- 6.1.2.11 If the value is not within the acceptable range, check for air in the tube and repeat the air purge (Start Purge and Stop Purge). Verify the pressure is 26+/-5 inH2O. If the pressure is still out of range, contact Technical Support.
- 6.1.2.12 If the value is within range press the '**NEXT**' icon and complete the breakdown steps as described. Press '**DONE**' when complete.

## 6.2 Technical Specifications

Table 4: Technical Specifications

Item	Specification
Model or type designation	FLT-200
Mains voltage range [V]	100-240 VAC
Supply Frequency Range [Hz]	50-60Hz
Fuse designation	T5AH, 250 V fuses
Mode of Operation	Non-continuous (Max Duty: 60 minutes ON, 30 minutes IDLE)
Power Consumption	350W
Upper Voltage Range	
Normal Operation	240 VAC
Peak	264 VAC
Lower Voltage Range	
Normal Operation	120 VAC
Peak	90 VAC
Protection class (I, II, III)	I
Application part type (B, BF, CF)	BF
Defibrillator protected (yes, no)	No
Protection type (IP code)	IP21
Conformity with the following standards	IEC 60601-1:2005 + A1:2012 + A2:2020 IEC 60601-1-6:2010 + A1:2013 + A2:2020 IEC 62366-1:2015 + A1:2020 IEC 62304:2006 +A1:2015 IEC 60601-1-2:2014 + A1:2020
Operating conditions	14-30°C / 57-86°F 20-80% rel. humidity, Non-Condensing 8000 ft (2438.4 Meters) max. altitude above sea level for use Atmospheric pressure: 75-101 kPa
Storage and transportation conditions	-30-60°C / -22-140°F 15-90% rel. humidity, Non-Condensing
Use possible with flammable anesthetic gases	No
Maximum sound level	≤75 decibels (dBa at 1meter)
Adjustable Values	
Pressure range (mmHg)	40 - 150
Deficit Limit (mL)	100 - 2500 at start of procedure 100 - 9950 after procedure has started
Measurement range	
Flow (mL/min)	0-1000
Deficit (mL)	±9999
Accuracy	



Item	Specification
Pressure (mmHg)	± 35
Flow (mL/min)	± 50
Deficit (mL)	± 50 under normal use
Dimensions (Width x Height x Depth)	23in x 67in x 27in / 584mm x 1702 mm x 686mm
System Weight	65Kg
Console Mass	45Kg
Safe Working Mass	20 Kg
Interfaces	
Signal IN/OUT components	None
Mains connection	IEC 60320-1 C14
Maximum Load Cell Capacity	<6.3Kg for Supply and Waste Bag Hooks
System Useful Life	The system shall have a useful life up to 5 years.

### 6.3 Power Cord Safety

Ensure the connection data and technical specifications of the power supply comply with DIN VDE or national requirements. The wall outlet power supply cord must be plugged into a properly installed safety wall plug (see DIN VDE 0107). Read the device label located in rear of pump to determine the operating voltage of the system.

The power connection must be equipped with a grounding contact. Use the Fluent Pro Fluid Management System power cord to establish a connection between the wall outlet and the power cord connection located in the rear of the system.

Only for U.S. operators: Use only a certified (UL-listed), removable power cord, type SJT, minimal 16 AWG, 3 leads. The plug connectors must comply with NEMA 5-15 or IEC 320/CEE22. Grounding will only be reliable if the equipment is connected to a corresponding hospital grade outlet.

Integrate the system into the potential equalization system as specified by local safety rules and regulations.

Medical devices are subject to special safety and protective measures concerning electromagnetic compatibility (hereafter abbreviated as EMC).

This system is to be used only for the purposes described in the manual and must be installed, set up, and operated in compliance with the EMC notes and instructions. See Section 6.4: Electromagnetic Compatibility.

### 6.4 Electromagnetic compatibility

#### 6.4.1 Electromagnetic Emissions Guidance and Manufacturer's Declaration

The Fluent Pro Fluid Management System is intended for use in the electromagnetic environment specified below. The customer or the user of the Fluent Pro Fluid Management System should ensure that it is used in such an environment. Non-observance of the instructions listed in this manual can lead to damage or malfunction of the system.



#### **WARNING!**

Use of accessories, transducers, and cables other than those specified or provided by the manufacturer of this equipment could result in increased electromagnetic emissions or decreased electromagnetic immunity of this equipment and result in improper operation.

Table 5: Electromagnetic Emissions Guidance

Emissions test	Compliance	Electromagnetic environment - guidance
RF emissions CISPR 11	Group 1	The Fluent Pro Fluid Management System uses RF energy only for its internal function. Therefore, its RF emissions are very low and are not likely to cause interference in nearby electronic equipment.
RF emissions CISPR 11	Group 2	The Fluent Pro Fluid Management System must emit electro-magnetic energy in order to perform its intended function. Nearby electronic equipment may be affected.

Emissions test	Compliance	Electromagnetic environment - guidance
RF emissions CISPR 11	Class A	The Fluent Pro Fluid Management System is suitable for use in all establishments other than domestic and those directly connected to the public low-voltage power supply network that supplies buildings used for domestic purposes.  Note: The EMISSIONS characteristics of this equipment make it suitable for use in industrial areas and hospitals (CISPR 11 class A). If it is used in a residential environment (for which CISPR 11 class B is normally required) this equipment might not offer adequate protection to radio-frequency communication services. The user might need to take mitigation measures, such as relocating or re-orienting the equipment.
Harmonic emissions IEC 61000-3-2	Complies	
Voltage fluctuations / flicker emissions IEC 61000-3-3	Complies	


#### 6.4.2 Electromagnetic Immunity Guidance and Manufacturer's Declaration

The Fluent Pro Fluid Management System is intended for use in the electromagnetic environment specified below. The customer or the user of the Fluent Pro Fluid Management System should ensure that it is used in such an environment. Non-observance of the instructions listed in this manual can lead to damage or malfunction of the system.

Table 6: Electromagnetic Immunity Guidance

Immunity test	IEC 60601 test level	Compliance level	Electromagnetic environment guidance
Electrostatic discharge (ESD) IEC 61000-4-2	± 8 kV contact ± 2, ± 4, ± 8, ± 15 kV air	± 8 kV contact ± 2, ± 4, ± 8, ± 15 kV air	Floors should be wood, concrete or ceramic tile. If floors are covered with synthetic material, the relative humidity should be at least 30%.
Electrical fast transients / bursts IEC 61000-4-4	± 2 kV for power supply lines ± 1 kV for input / output lines	± 2 kV for power supply lines ± 1 kV for input/output lines	Mains power quality should be that of a typical commercial or hospital environment.
Surge IEC 61000-4-5	± 1 kV line(s) to line(s) ± 2 kV line(s) to earth	± 1 kV line(s) to line(s) ± 2 kV line(s) to earth	Mains power quality should be that of a typical commercial or hospital environment.
Voltage dips, short interruptions, and voltage variations on power supply input lines IEC 61000-4-11	0% UT (100% dip in the UT) for ½ cycle at 0°, 45°, 90°, 135°, 180°, 225°, 270°, and 315°	0% UT (100% dip in the UT) for ½ cycle at 0°, 45°, 90°, 135°, 180°, 225°, 270°, and 315°	Mains power quality should be that of a typical commercial or hospital environment.  If the user/operator of the Fluent Pro Fluid Management System requires continued operation during power mains interruptions, it is recommended that the Fluent Pro Fluid Management System be powered from an uninterruptible power supply or battery.
	0% UT (100% dip in the UT) for 1 cycle and 70% (30% dip in the UT) UT for 25/30 cycles at 0°	0% UT (100% dip in the UT) for 1 cycle and 70% (30% dip in the UT) UT for 25/30 cycles at 0°	
	0% UT (100% dip in the UT) for 250/300 cycles	0% UT (100% dip in the UT) for 250/300 cycles	
Power frequency (50/60 Hz) magnetic field IEC 61000-4-8	30 A/m	30 A/m	Power frequency magnetic fields should be at levels characteristic of a typical location in a typical commercial or hospital environment.



Immunity test	IEC 60601 test level	Compliance level	Electromagnetic environment guidance
Conducted RF IEC 61000-4-6	3 Vrms 150 kHz to 80 MHz 6 Vrms in ISM Bands between 150kHz and 80 MHz	3 Vrms 150 kHz to 80 MHz 6 Vrms in ISM Bands between 150kHz and 80 MHz	Portable and mobile RF communications equipment used no closer to any part of the Fluent Pro Fluid Management System, including cables, than the recommended separation distance calculated from the equation applicable to the frequency of the transmitter. Recommended safety distance: $d = 1.2\sqrt{P}$ for 150 KHz to 80 MHz $d = 1.2\sqrt{P}$ for 80 MHz to 800 MHz $d = 2.3\sqrt{P}$ for 800 MHz to 2.7 GHz Where P as the maximum output power rating of the transmitter in watts [W] according to the transmitter manufacturer d as recommended separation distance in meters [m].
Radiated HF interference quantities according to IEC 61000-4-3	3 V/m 80 MHz to 2.7 GHz	3 V/m 80 MHz to 2.7 GHz	Field strengths from fixed RF transmitters, as determined by an electromagnetic site survey a, should be less than the compliance level in each frequency range. b
Enclosure Port Immunity to RF Wireless Communications	Per Table 9 of the IEC 60601-1-2 standard	See table 7 for frequency ranges and test conditions for RF wireless communications equipment	Interference may occur in the vicinity of equipment marked with the following symbol: 
IEC 60601-1-2 Table 11: Enclosure Port Immunity to Proximity Magnetic Fields according to IEC 60601-1-2	30 kHz, 8 A/m, CW Modulation  134.2 kHz, 65 A/m, 2.1 kHz Pulse Modulation  13.56 MHz, 7.5 A/m, 50 kHz Pulse Modulation	30 kHz, 8 A/m, CW Modulation  134.2 kHz, 65 A/m, 2.1 kHz Pulse Modulation  13.56 MHz, 7.5 A/m, 50 kHz Pulse Modulation	

Note \*: UT is the AC mains voltage prior to application of the test level. Note 1: At 80 MHz and 800 MHz, the higher frequency range applies.

Note 2: These guidelines may not apply in all situations. Electromagnetic propagation is affected by absorption and reflection of structures, objects, and people.

a) Field strengths from fixed transmitters, such as base stations for radio (cellular/cordless) telephones and land mobile radios, amateur radio, AM and FM radio broadcast and TV broadcast cannot be predicted theoretically with accuracy. To assess the electromagnetic environment due to fixed RF transmitters, an electromagnetic site survey should be considered. If the measured field strength in the location in which the Fluent Pro Fluid Management System is used exceeds the applicable compliance level above, the Fluent Pro Fluid Management System should be observed to verify normal operation. If abnormal performance is observed, additional measures may be necessary, such as re-orienting or relocating the changing orientation or the location of the Fluent Pro Fluid Management System.

b) Over the frequency range of 150 kHz to 80 MHz, field strengths should be less than 3 V/m.

Table 7: Guidance and Manufacturer’s Declaration – Electromagnetic Immunity

Frequency ranges and test conditions for RF wireless communications equipment			
Frequency band (MHz)	Test frequency (MHz)	Modulation <sup>a</sup>	Compliance level (V/m)
380-390	380-390	Pulse – 18 Hz	27
430-470	450	FM ±5 kHz deviation 1 kHz sine	28
704-787	710	Pulse – 217 Hz	9
	745		
	780		
800-960	810	Pulse – 18 Hz	28
	870		
	930		
1700-1990	1720	Pulse – 217 Hz	28
	1845		
	1970		
2400-2570	2450	Pulse – 217 Hz	28
5100-5800	5240	Pulse – 217 Hz	9
	5500		
	5785		

<sup>a</sup>Pulse Modulation is defined as a square wave input with a 50% duty cycle at the listed frequency.

**6.4.3 Recommended Separation Distances**

The Fluent Pro Fluid Management System is intended for use in an electromagnetic environment in which radiated RF disturbances are controlled. The customer or the user of the Fluent Pro Fluid Management System can help prevent electromagnetic interference by maintaining a minimum distance between portable and mobile RF communications equipment (transmitters) and the Fluent Pro Fluid Management System as recommended below, according to maximum output power of the communications equipment.

The following table lists the recommended separation distances between portable and mobile RF communications equipment and the Fluent Pro Fluid Management System.

Table 8: Recommended Separation Distances

Rated maximum output power of transmitter [W]	Separation distance according to frequency of transmitter [m]		
	150 kHz to 80 MHz d = 1.2√P	80 MHz to 800 MHz d = 1.2√P	800 MHz to 2.7 GHz d = 2.3√P
0.01	0.12	0.12	0.23
0.1	0.38	0.38	0.73
1	1.2	1.2	2.3
10	3.8	3.8	7.3
100	12	12	23

For transmitters rated at a maximum output power not listed above, the recommended separation distance d in meters (m) can be estimated by using the equation applicable to the frequency of the transmitter, where P is the maximum output power rating of the transmitter in watts [W] according to the transmitter manufacturer.

Note 1: At 80 MHz and 800 MHz, the separation distance for the higher frequency range applies.

Note 2: These guidelines may not apply in all situations. Electromagnetic propagation is affected by absorption and reflection from structures, objects, and people.

### 6.5 Console Disposal

This equipment contains electronic printed circuit assemblies. Consult your local regulations for disposal/electronics recycling. Do not place into a municipal waste system unless authorized to do so by local authorities. At the end of the useful life of the equipment, it should be disposed of in accordance with any applicable national or institutional related policy relating to obsolete electronic equipment.

### 6.6 Procedure Kit Storage

The Fluent Pro Procedure Kit should be stored at room temperature away from moisture and direct heat. Do not use after expiration date.

### 6.7 Procedure Kit Disposal

The used disposable device must be treated as biohazardous waste and disposed of according to standard practices of the hospital or surgery center where the procedure took place.

### 6.8 Disposables and Accessories

The system may only be connected with a hysteroscope designed for and featuring the technical specification permitting such a combined use. Any utilized hysteroscope must comply with the most recent versions of IEC 60601-2-18 and ISO 8600.

Table 9: Disposables and Accessories

Item	Order Number
Package of Six (6) Fluent Pro Procedure Kits (In-FloPak, Out-FloPak, Tissue Trap and Waste Bag)	FLT-212
Fluent Pro Disposable Pack (single)	FLT-212S
Fluent Pro Waste Bag - Five Pack	FLT-205
Fluent Pro Tissue Trap - Ten Pack	FLT-210
MyoSure Tissue removal device	10-403
MyoSure Lite Tissue removal device	30-403LITE
MyoSure Reach Tissue removal device	10-403FC
MyoSure XL for Fluent Tissue removal device	50-603XL
500g Weight	MME-03095
Fluent Pro Power Cord	MEL-01716
Foot Pedal	52124-001

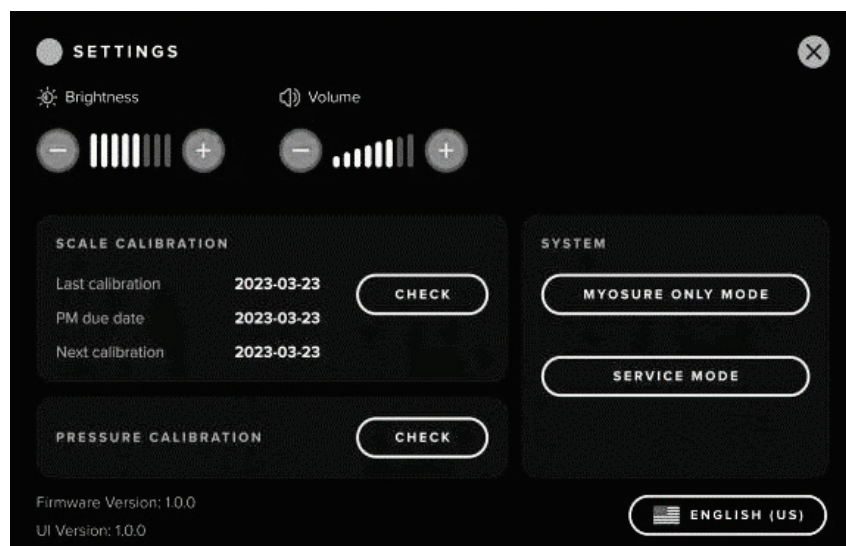
## 6.9 Service and Warranty Information

### 6.9.1 Authorized Service Technician Maintenance

It is recommended that Hologic Personnel perform maintenance of the system at appropriate intervals to ensure safety and functionality. The minimum service interval is two years, depending on frequency and duration of use.

If this interval is not maintained, the manufacturer does not assume any liability for the functional safety of the system. The settings screen of the Fluent Pro Fluid Management System tracks when preventative maintenance (PM) is required, as shown in the figure below:

Figure 81: Preventative Maintenance Due Date



### 6.9.2 Warranty Information

Except as otherwise expressly stated in the Agreement: i) Equipment manufactured by Hologic is warranted to the original Customer to perform substantially in accordance with published product specifications for one (1) year starting from the date of shipment, or if Installation is required, from the date of Installation ('Warranty Period'); ii) digital imaging mammography x-ray tubes are warranted for twenty-four (24) months, during which the x-ray tubes are fully warranted for the first twelve (12) months and are warranted on a straight-line prorated basis during months 13- 24; iii) replacement parts and remanufactured items are warranted for the remainder of the Warranty Period or ninety (90) days from shipment, whichever is longer; iv) consumable Supplies are warranted to conform to published specifications for a period ending on the expiration date shown on their respective packages; v) licensed Software is warranted to operate in accordance with published specifications; vi) Services are warranted to be supplied in a workman-like manner; vii) non-Hologic Manufactured Equipment is warranted through its manufacturer and such manufacturer's warranties shall extend to Hologic's customers, to the extent permitted by the manufacturer of such non-Hologic Manufactured Equipment. Hologic does not warrant that use of Products will be uninterrupted or error-free, or that Products will operate with non-Hologic authorized third-party products.

These warranties do not apply to any item that is: (a) repaired, moved, or altered other than by Hologic authorized service personnel; (b) subjected to physical (including thermal or electrical) abuse, stress, or misuse; (c) stored, maintained, or operated in any manner inconsistent with applicable Hologic specifications or instructions, including Customer's refusal to allow Hologic recommended Software upgrades; or (d) designated as supplied subject to a non-Hologic warranty or on a pre-release or 'as-is' basis.

### 6.9.3 Technical Support and Product Return Information

Contact Hologic Technical Support for proper disposal of any part of the Fluent Pro Fluid Management System if it fails to operate as intended. If product is to be returned to Hologic for any reason, Technical Support will issue a Returned Materials Authorization (RMA) number and biohazard kit if applicable. Return the Fluent Pro Fluid Management System according to the instructions provided by Technical Support. Be sure to clean the product before returning it and include all accessories in the box with the returned unit. Return used or opened product according to the instructions provided with the Hologic-supplied biohazard kit.

6.9.4 **Complaints Reporting:**

Report any complaints or problems with the quality, reliability, safety, or performance of this product to Hologic. If the device has caused or added to patient injury, immediately report the incident to Hologic Authorized Representative and Competent authority of the respective member state or country. The Competent Authorities for medical devices are usually the individual Member States' Ministry of Health, or an agency within the Ministry of Health.

6.9.5 **Contacting Hologic Technical Support**

Contact Hologic Technical Support to arrange for proper disposal of the Fluent Pro Fluid Management System in accordance with the WEEE Directive.

Hologic Technical Support

United States and Canada:



Hologic, Inc  
250 Campus Drive  
Marlborough, MA 01752

Phone: 1.800.442.9892 (toll-free)






www.hologic.com




**6.10 Symbol Glossary**

Table 10: Symbols

Symbol	Standard Reference & Symbol Number	Title of Symbol	Description of Symbol
	EN ISO 15223-1 5.1.1 ISO 7000-3082	Manufacturer	Indicates the medical device manufacturer
	EN ISO 15223-1 5.1.3 ISO 7000-2497	Date of manufacturer	Indicates the date when the medical device was manufactured
	EN ISO 15223-1 5.1.11 ISO 7000-6049	Country of manufacture	To identify the country of manufacture of products
	EN ISO 15223-1 5.1.4 ISO 7000-2607	Use-by date	Indicates the date after which the medical device is not to be used
	EN ISO 15223-1 5.2.6 ISO 7000-2608	Do not re-sterilize	Indicates a medical device that is not to be re-sterilized
	EN ISO 15223-1 5.4.2 ISO 7000-1051 IEC 60601-1, Table D.1, 28	Do not re-use	Indicates a medical device that is intended for one single use only
	EN ISO 15223-1 5.2.8 ISO 7000-3082	Do not use if package is damaged and consult instructions for use	Indicates that a medical device that should not be used if the package has been damaged or opened and that the user should consult the instructions for use for additional information
	EN ISO 15223-1 5.3.7 ISO 7000-0632	Temperature limit	Indicates the temperature limits to which the medical device can be safely exposed
	EN ISO 15223-1 5.4.3 ISO 7000-1641 IEC 60601-1, Table D.1, 11	Consult instructions for use	Indicates the need for the user to consult instructions for use
	EN ISO 15223-1 5.1.5 ISO 7000- 2492	Batch code	Indicates the manufacturer's batch code so that the batch or lot can be identified
	EN ISO 15223-1 5.1.6 ISO 7000- 2493	Catalog Number	Indicates the manufacturer's catalogue number so that the medical device can be identified
	EN ISO 15223-1 5.1.7 ISO 7000-2498	Serial Number	Indicates the manufacturer's serial number so that a specific medical device can be identified
	EN ISO 15223-1 5.2.3 ISO 7000-2501	Sterilized using ethylene oxide	Indicates a medical device that has been sterilized using ethylene oxide
	EN ISO 15223-1 5.2.11 ISO 7000-3707	Single sterile barrier system	Indicates a single sterile barrier system
	EN ISO 15223-1 5.3.8 ISO 7000-2620	Humidity limitation	Indicates the range of humidity to which the medical device can be safely exposed
	EN ISO 15223-1 5.3.9 ISO 7000-2321	Atmospheric pressure limitation	Indicates the range of atmospheric pressure to which the medical device can be safely exposed
	EN ISO 15223-1 5.7.7	Medical Device	Indicates the item is a medical device
	EN ISO 15223-1 5.7.10	Unique device identifier	Indicates a carrier that contains unique device identifier information

## Fluent Pro Fluid Management System

Symbol	Standard Reference & Symbol Number	Title of Symbol	Description of Symbol
	EN ISO 15223-1 5.4.4 ISO 7000- 0434A	Caution	Indicates that caution is necessary when operating the device or control close to where the symbol is placed, or that the current situation needs operator awareness or operator action in order to avoid undesirable consequences
	EN ISO 15223-1 5.4.5 and Annex B ISO 7000-2725	Product is not made from natural rubber latex	Indicates that natural rubber latex was not used in the manufacturing of the product, its container, or its packaging.
	FDA 21 CFR 801.109	Prescription use only	Caution: Federal law restricts this device to sale by or on the order of a physician
	ISO 7010-M002	IEC 60601-1	Refer to instruction manual/booklet. To signify that the instruction manual/booklet must be read.
	IEC 60417-6414 EN 50419 Directive 2012/19/EU	WEEE; Waste Electrical and Electronic Equipment	To indicate that separate collection for waste electric and electronic equipment (WEEE) is required.

Symbol	Standard Reference & Symbol Number	Title of Symbol	Description of Symbol
	EN 15986 4.2, Annex A and Annex B ISO 7000-2725	Does not contain phthalates (DEHP)	Indicates the item does not contain phthalates (DEHP)
	ISO 7000-2794	Packaging unit	To indicate the number of pieces in the package.
	IEC 60417-5333	Type BF applied part	Identifies a type BF applied part complying with IEC 60601-1
<b>IP21</b>	IEC 60529 IEC 60601-1	Degrees of protection provided by enclosures	System is protected against solid objects of 12.5mm or greater and protected against vertically falling drops of water condensation.

Hologic, Fluent, MyoSure, In-FloPak, Out-FloPak and associated logos are registered trademarks of Hologic, Inc. and/or its subsidiaries in the United States and other countries. All other trademarks, registered trademarks, and product names are the property of their respective owners.

©2018-2024 Hologic Inc.

## 6.11 Glossary

Term	Definitions
Contraindication	Circumstances (e.g., age, pregnancy, certain illness, medication) prohibiting the use of an otherwise indicated measure (contrary to an indication)
Deficit	The total amount of fluid left in the patient or unaccounted for otherwise. The fluid left in the patient must be monitored.
Embolism	Obstruction of a blood vessel by a clot or air bubble
Flow rate	Quantity (in mL) of distension fluid flowing through the tubing per minute.
Hypervolemia	An increased volume of circulating blood.
Hyponatremia	A low concentration (< 130 mmol/L) of sodium in the patient's bloodstream.
Hysteroscope	An instrument designed to provide visual examination of the uterus
IUP	Intrauterine Pressure, the pressure in the uterine cavity.
Intravasation	Entry of foreign material (distention fluid) into the blood vessels
Saline	Isotonic saline solution, i.e., one liter (L) contains 9.0 grams of sodium chloride.
Tissue Trap	A component between the waste outflow and waste bag that separates tissue from fluid and collects resected tissue throughout the procedure to allow the tissue to be sent to pathology.
TRD	Tissue Removal Device
GUI	Graphical User Interface







# HOLOGIC<sup>®</sup>

Hologic, Inc.  
250 Campus Drive  
Marlborough, MA 01752 USA  
1-800-422-9892  
[www.hologic.com](http://www.hologic.com)

Patents: <http://hologic.com/patentinformation>

MAN-11714-001 Rev. 001  
09/2024