

MyoSure® Rod Lens Hysteroscope

Instructions for Use



Rx U.S. FEDERAL LAW RESTRICTS THIS DEVICE TO SALE BY OR ON THE ORDER OF A PHYSICIAN

Read these instructions completely prior to using the MyoSure Rod Lens Hysteroscope.

These instructions describe two MyoSure Rod Lens Hysteroscopes:

Catalogue number	Product	Hysteroscope working channel diameter	Outflow channel part number	Compatible MyoSure Tissue Removal Devices <i>Note: All Models may not be available in all regions. Contact your Hologic Representative for a list of models available in your region.</i>
REF 40-250	MyoSure Rod Lens Hysteroscope	3 mm	REF 40-201	MyoSure Tissue Removal Device REF 10-401 MyoSure LITE Tissue Removal Device REF 30-401LITE MyoSure REACH Tissue Removal Device REF 10-401FC
REF 50-250XL	MyoSure XL Rod Lens Hysteroscope	4 mm	REF 50-201XL	MyoSure Tissue Removal Device REF 10-401 MyoSure LITE Tissue Removal Device REF 30-401LITE MyoSure XL Tissue Removal Device REF 50-501XL MyoSure REACH Tissue Removal Device REF 10-401FC

TABLE 1.

Device Description

The MyoSure Rod Lens Hysteroscope is intended for use in visualizing the uterine cavity and performing operative hysteroscopy procedures including use with the MyoSure Tissue Removal Device. The MyoSure Rod Lens Hysteroscope system includes a removable outflow channel and the hysteroscope. The removable outflow channel is intended to be used to provide a fluid outflow lumen when the hysteroscope is being used in a diagnostic mode. The removable outflow channel includes a sealed entry port to permit the introduction of instrumentation.

The reusable rod lens hysteroscope utilizes rod lenses for visualization and fibers for illumination. The hysteroscope includes a working channel designed to accommodate the respective MyoSure Tissue Removal Device. (See Table 1.)

The Operative Hysteroscopy System can be combined with a hysteroscopic fluid management system to provide continuous flow hysteroscopy capability. The hysteroscope is normally coupled to a camera and video display unit for visualization.

Indications for Use

The MyoSure Rod Lens Hysteroscope is used to provide viewing of the cervical canal and the uterine cavity for the purpose of performing diagnostic and surgical procedures.

Diagnostic Hysteroscopy

- Abnormal uterine bleeding
- Infertility and pregnancy wastage
- Evaluation of abnormal hysterosalpingogram
- Intrauterine foreign body
- Amenorrhhea
- Pelvic Pain

ENGLISH

Operative Hysteroscopy

- Directed biopsy
- Removal of submucous fibroids and large polyps
- Submucous Myomectomy (see Contraindications)
- Transection of intrauterine adhesions
- Transection of intrauterine septa

Contraindications

- Acute pelvic inflammatory disease

Hysteroscopy may also be contraindicated by the following conditions, depending on their severity or extent:

- Inability to distend uterus
- Cervical stenosis
- Cervical/vaginal infection
- Uterine bleeding or menses
- Known pregnancy
- Invasive carcinoma of the cervix
- Recent uterine perforation
- Medical contraindication or intolerance to anesthesia

Contraindications to Hysteroscopic Myomectomy

Hysteroscopic myomectomy should not be undertaken without adequate training, preceptorship, and clinical experience. The following are clinical conditions that can significantly complicate hysteroscopic myomectomy:

- Severe anemia
- Inability to circumnavigate a myoma due to myoma size (e.g., predominantly intramural myomas with small submucous components).

Warnings

- **For use only by physicians trained in hysteroscopy**
- **Suspicion of pregnancy should suggest a pregnancy test before the performance of diagnostic hysteroscopy.**
- **The MyoSure hysteroscope is only to be used in conjunction with accessories that comply with the following safety standards: National/Regional versions of IEC 60601-1, the general safety requirements for medical devices; and, as applicable, IEC 60601-2-18, particular safety requirements for endoscope equipment and accessories; and IEC 60601-2-2, particular safety requirements for High Frequency (HF) surgical equipment and accessories. Before using any accessory, be sure to follow the instructions provided with the accessory, including in the case of a HF electrode, the maximum recurring peak voltage rating.**
- **When using HF surgical equipment, keep the working part of the active electrode in the field of view to avoid accidental burns.**
- **The hysteroscope and outflow channel are shipped non-sterile. They must be thoroughly cleaned and sterilized before use.**
- **If scope light post adapters have been used, they need to be disassembled, cleaned, and sterilized before every subsequent use.**
- **Uterine perforation can result in possible injury to bowel, bladder, major blood vessels, and ureter.**
- **High energy radiated light emitted from illuminating fiber at the distal end of the scope may give rise to temperatures exceeding 106°F/41°C (within 8 mm in front of the scope).**

Do not leave tip of scope in direct contact with the patient tissue or combustible materials, as burns may result. Lower the light source output when working in close proximity to the object.

- **The hysteroscope light post and adapter may exceed temperatures of 41°C. Hysteroscopes should not be placed on the patient or on combustible materials, as burns may result.**
- **To prevent potential safety hazard to the patient caused by accidental loss of function of the device (i.e., front end damage by surgical instruments) it is recommend to have an additional sterile “stand-by” device during surgical procedures.**
- **When scopes are used with laser equipment, appropriate filtering spectacles must be worn by the operating team. In some cases, a specific filter must be put between the scope and camera head to prevent camera damage by high-power laser radiation. Contact your laser supplier for details. To prevent scope damage by high-power laser radiation, always ensure that the laser delivery fiber is seen through the scope and not directed at the scope before energizing the laser.**

For Continuous Flow Hysteroscopy:

- **If liquid distension medium is used, strict fluid intake and output surveillance should be maintained. Intrauterine instillation exceeding 1 liter should be followed with care due to the possibility of fluid overload.**

Potential Complications of Continuous Flow Hysteroscopy:

- **Hyponatremia**
- **Hypothermia**
- **Uterine perforation resulting in possible injury to adjacent anatomy**
- **Pulmonary edema**
- **Cerebral edema**

Precautions

- Vaginal ultrasonography before hysteroscopy may identify clinical conditions that will alter patient management.
- Intrauterine distension can usually be accomplished with pressures in the range of 35–75 mm Hg. Unless the systemic blood pressure is excessive, it is seldom necessary to use pressures greater than 75–80 mm Hg.
- Do not use the seals if the sterile package is open or appears compromised. Do not use the device if damage is observed.
- Avoid exposing the scope to sudden temperature changes. Do not immerse hot scopes into cold water or liquid.
- Any mechanical manipulation of the eyepiece may result in seal breakage, therefore do not attempt to remove the eyepiece.
- Avoid contact with metal parts of the scope and other conductive accessories by ensuring before activation of the HF output that the active electrode is at a sufficient distance from the tip of the scope.
- To avoid perforation, do not use the scope tip as a probe and exercise caution when the scope is being inserted through the cervix and when the scope tip is near the uterine wall.

Inspection Prior to Use

Prior to each use, the outer surface of the insertion portion of the hysteroscope should be inspected to ensure there are no

unintended rough surfaces, sharp edges or protrusions. Check that both the hysteroscope and outflow channel contain seals.

Hysteroscope System Set-up Instructions

The MyoSure Rod Lens Hysteroscope consists of a removable outflow channel (40-201) and hysteroscope (40-200) as shown in Figure 1.

The MyoSure XL Rod Lens Hysteroscope consists of a removable outflow channel (50-201XL) and hysteroscope (50-200XL).

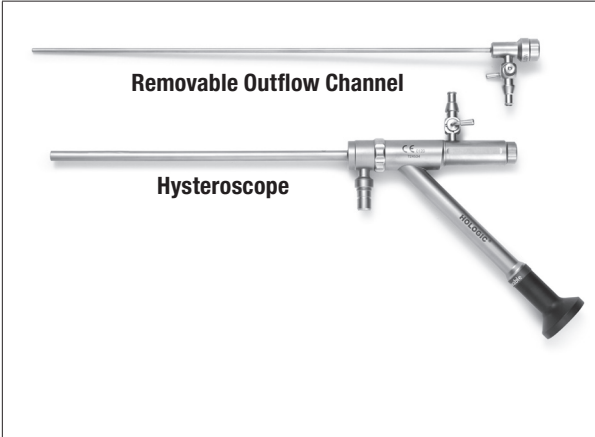

FIGURE 1. REPRESENTATIVE HYSTEROSCOPE & OUTFLOW CHANNEL

To place removable outflow channel into hysteroscope:

Insert the removable outflow channel into the proximal seal of the hysteroscope working channel. Reverse this process to remove the outflow channel.

To Insert Sterile Single-Use Seal (40-902):

Both the hysteroscope and the outflow channel contain single-use seals for their working channels. Figure 2 below illustrates the installation of the seals.

Caution: To ensure proper performance of the system and prevent leaks, install new seals in the hysteroscope and the outflow channel prior to use.

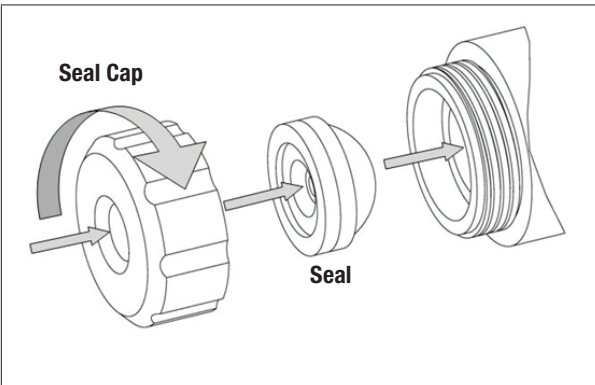

FIGURE 2. SEAL INSTALLATION

To Attach Fluid Connections:

The hysteroscope accepts a standard male luer connection for fluid inflow. The Removable Outflow Channel includes a universal stopcock for both luer and friction connections.

Needed Equipment for Indicated Procedures

Fiber optic light source, fiber optic light guide (not supplied with this product)

Hysteroscope Assembly/Disassembly Instructions

The MyoSure Rod Lens Hysteroscope is compatible with Metal-Halide and Xenon light sources with up to 300 watts of power.

Place the correct adapter on the light post of the fiber optic scope and on the instrument end of the light guide. Adapters are available for connection to Storz, Olympus, Wolf, and ACMI light sources as shown in Figure 3.

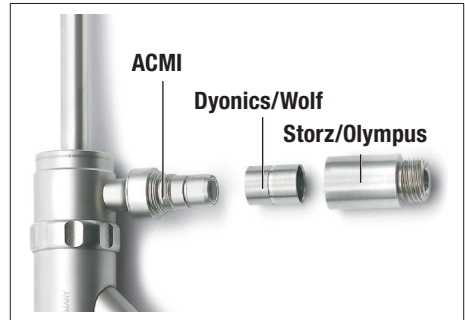

FIGURE 3. LIGHT POST ADAPTERS

The light post threads may be lubricated as needed, being sure to remove any excess lubricant as required. Make sure that the fiber optic surface remains free of foreign matter. Do not use tools to tighten the adapters – hand tighten only.

Directions for Use

The surgeon may look through the direct-view hysteroscope (with eyepiece) directly with his or her eye. If a video system is being connected to the scope, thread a camera coupler onto the camera head and then insert the eyepiece into the camera coupler.

Plug the video cable into the camera control unit (CCU).

Turn on the power to the monitor, CCU, and light source. Adjust the video system components per the manufacturer’s instructions. The system is now ready to use.

Hysteroscope Cleaning Instructions—General

The device should not be allowed to dry after procedure before cleaning to ensure effective removal of contaminant material.

- If still inserted, separate the removable outflow channel from the hysteroscope.
- Light post adaptors must be removed prior to cleaning and sterilization.
- Remove single-use seals from hysteroscope and removable outflow channel
- Warning: Failure to remove the single-use seals from hysteroscope and removable outflow channel will affect proper cleaning and sterilization of the product.
- Open the stopcocks on the hysteroscope and removable outflow channel.
- Flush all lumens of the hysteroscope and removable outflow channel with warm tap water
- Scrub the hysteroscope and removable outflow channel using a nylon-bristled brush that is suitable to contact the full interior dimensions (diameter and length) of the lumens. Scrub all surfaces, crevices, interior cavities of the stopcock and lumens

ENGLISH

to remove any visible debris. Do not scratch any of the optical surfaces.

- The following brushes dimensions are recommended
 - For the main lumen, a nylon-bristled brush with bristle area length of 2" (50mm), bristle diameter of .236" (6mm) and an overall length of 14" (35cm) is recommended
 - For all other lumens, a nylon-bristled brush with bristle area length of 2" (50mm), bristle diameter of .197" (5mm) and an overall length of 14" (35cm) is recommended
- Utilizing the stopcocks, flush the lumens with an enzymatic, neutral pH cleaner a minimum of three (3) times ensuring that no air remains within the lumen.
- Hysteroscope, removable outflow channel and accessory components should be soaked in an enzymatic, neutral pH cleaner in accordance with cleaning solution instructions.
- Thoroughly rinse the hysteroscope, including flushing all lumens and accessory components to completely remove the cleaning solution.
- Dry the hysteroscope with a lint free soft cloth or filtered compressed air.
- Check visually for cleanliness to ensure that all debris have been removed. If not visually clean, repeat reprocessing steps until the device is visually clean.

Hysteroscope Cleaning Instructions— Optical Surfaces

Due to insufficient cleaning or foreign matter contamination, deposits may develop on the three optical surfaces of the hysteroscope as shown below.

These are:

- The distal tip
- The proximal window or eyepiece
- The fiber optic light post

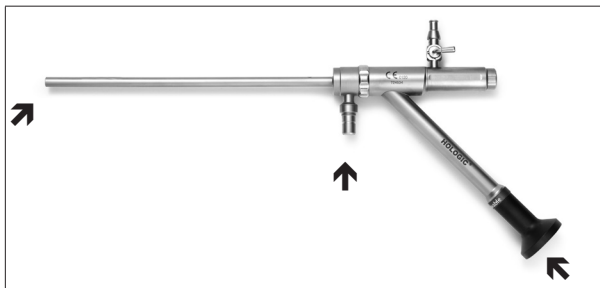

To remove these deposits, a tube of bio-compatible polishing paste is enclosed with each hysteroscope.

To remove the deposits, dab some polishing paste onto a clean, cotton-tipped swab. Gently press the swab onto the optical surface to be cleaned and scrub the surface with a circular motion. Rinse the optical surface with water to remove any remaining polishing paste.

NOTE: Cleaning should only be performed when the image as viewed through the scope is cloudy, and not as part of your routine cleaning procedures.

NOTE: Do not use any ultrasonic cleaning methods. The energy transmitted through fluid cavitations will damage seals and optical surfaces and will void the warranty.

NOTE: Foreign matter remaining on the fiber surface of the light post after cleaning may tend to burn and discolor the surface when exposed to a high intensity light source.

Sterilization

Hysteroscope and outflow channel should be sterilized in a container which secures the instruments in place. Be sure the distal working length does not experience any undue forces or stress which can damage the delicate internal optics.

Sterilize the hysteroscope and outflow channel with the following validated steam autoclave, ethylene oxide (EtO) gas, Sterrad® or STERIS Amsco® V-PRO® methods.

Ethylene Oxide (100% EtO – wrapped)

Follow standard hospital procedure maintaining the following parameters:

Temperature:	131° ± 5°F (55°C)
Relative Humidity:	35–70%
Gas Concentration:	~ 736 mg/l
Exposure Time:	60 minutes
Aeration Time:	11 hours

Sterrad®—Devices meet guidelines for Sterrad 100S, NX, and 100NX systems and require the use of a Sterrad-compatible tray or container systems. Refer to manufacturer's Instructions for Use for more information. STERIS® Amsco® V-PRO® Devices meet guidelines for Amsco® V-PRO® 1, V-PRO 1 Plus and V-PRO maX Low Temperature Sterilization Systems and should use the STERIS compatible tray or container systems. Refer to manufacturer's Instructions for Use for more information.

Steam Autoclave Wrapped

Follow standard hospital procedures:

Pre-vacuum method:	270°F (132°C) for 4 minutes and 30 minutes dry time
Gravity method:	270°F (132°C) for 15 minutes and 30 minutes dry time

IMPORTANT: It is recommended that the institution employ procedures which include the use of biological indicators in order to determine the effectiveness of the sterilization process.

Maintenance

We recommend that you inspect the hysteroscope carefully before and after the procedure for possible signs of damage.

First, check the image quality of the scope by viewing the monitor. If image quality is impaired:

- Check the distal and proximal lenses of the hysteroscope for cracked or scratched lenses.
- Check the surface cleanliness of the distal and proximal lenses. A foggy or cloudy image can be the result of moisture entering the optical system or lack of cleanliness of exterior surfaces. When viewing reflected light, the surfaces should appear smooth and shiny.

As a second step, check the illumination system of the scope. Reduced brightness can result from fiber damage:

- Check for fiber optic damage in the scope by holding the distal end of the scope toward a low power light and observing the light post on the hub. The center of the light post should appear clear or white. Noticeable black spots indicate serious damage

to the fiber illumination bundle in the scope. This will affect light transmission and the brightness of the image viewed on the monitor.

- Check the light cable for damaged fibers by holding one end of the cable toward a low power light and observing the other end. Broken fiber will appear as black spots in the light field. A damaged light cable will affect its ability to transmit light and the brightness of the image viewed on the monitor.

Storage

The MyoSure Rod Lens Hysteroscope and Removable Outflow Channel should be stored either in their shipping box or in a sterilization tray. In either case, proper care should be taken to ensure that the hysteroscope and outflow channel are immobile to prevent any damage.

Service - Accessories

The following are replacement/service parts for the MyoSure Rod Lens Hysteroscopes and Removable Outflow Channels:

REF	Description
40-201	Replacement MyoSure Outflow Channel
50-201XL	Replacement MyoSure XL Outflow Channel
ASY-04996	Hysteroscope Light Source Adapters - 1 each: Wolf and Storz
40-902	MyoSure Single Use Seal Set - 10 per box
40-904	MyoSure Hysteroscope and Outflow Channel Seal Cap

WARRANTY, SERVICE, AND REPAIR

WARRANTIES

Except as otherwise expressly stated in the Agreement: i) Equipment manufactured by Hologic is warranted to the original Customer to perform substantially in accordance with published product specifications for one (1) year starting from the date of shipment, or if Installation is required, from the date of Installation (“Warranty Period”); ii) digital imaging mammography x-ray tubes are warranted for twenty-four (24) months, during which the x-ray tubes are fully warranted for the first twelve (12) months and are warranted on a straight-line prorated basis during months 13-24; iii) replacement parts and remanufactured items are warranted for the remainder of the Warranty Period or ninety (90) days from shipment, whichever is longer; iv) consumable Supplies are warranted to conform to published specifications for a period ending on the expiration date shown on their respective packages; v) licensed Software is warranted to operate in accordance with published specifications; vi) Services are warranted to be supplied in a workman-like manner; vii) non-Hologic Manufactured Equipment is warranted through its manufacturer and such manufacturer’s warranties shall extend to Hologic’s customers, to the extent permitted by the manufacturer of such non-Hologic Manufactured Equipment. Hologic does not warrant that use of Products will be uninterrupted or error-free, or that Products will operate with non-Hologic authorized third-party products.

These warranties do not apply to any item that is: (a) repaired, moved, or altered other than by Hologic authorized service personnel; (b) subjected to physical (including thermal or electrical)

abuse, stress, or misuse; (c) stored, maintained, or operated in any manner inconsistent with applicable Hologic specifications or instructions, including Customer’s refusal to allow Hologic recommended Software upgrades; or (d) designated as supplied subject to a non-Hologic warranty or on a pre-release or “as-is” basis.

TECHNICAL SUPPORT AND PRODUCT RETURN INFORMATION

Contact Hologic Technical Support if the MyoSure Hysteroscopic Tissue Removal System fails to operate as intended. If product is to be returned to Hologic for any reason, Technical Support will issue a Returned Materials Authorization (RMA) number and biohazard kit if applicable. Return the MyoSure Hysteroscopic Tissue Removal System according to the instructions provided by Technical Support. Be sure to clean and sterilize the product before returning it and include all accessories in the box with the returned unit.

Return used or opened product according to the instructions provided with the Hologic-supplied biohazard kit.

For More Information

For technical support or reorder information in the United States, please contact:



Hologic, Inc.
 250 Campus Drive
 Marlborough, MA 01752 USA
 Phone: 1.800.442.9892 (toll-free)
 www.hologic.com

International customers, contact your distributor or local Hologic Sales Representative:

EC	REP	European Representative Hologic Ltd. Heron House Oaks Business Park, Crewe Road Wythenshawe, Manchester. M23 9HZ, UK Phone: +44 (0)161 946 2206
----	-----	---

Hologic, MyoSure, and associated logos are registered trademarks of Hologic, Inc. and/or its subsidiaries in the United States and other countries. All other trademarks, registered trademarks, and product names are the property of their respective owners.

© 2014-2017 Hologic, Inc.